

FORMAX[®]

6308 Series
Mid-Volume Inserting System

Table of Contents

- 1 Read this First 1**
 - Safety..... 1
 - Declaration of Conformity (EU only)..... 1
 - About this manual..... 1

- 2 How this Help Works 3**
 - Help Menu..... 3
 - User Guide..... 4
 - Remote Assistance (optional)..... 4

- 3 Meet your Document System 6**
 - Introduction..... 6
 - System Overview..... 7
 - Operating Controls..... 8
 - Control Panel..... 10
 - Power Up..... 11
 - How to Operate the Touch Screen..... 12
 - What is a Job?..... 16
 - Job List..... 17
 - Job Overview..... 18
 - High Capacity Document Feeder (HCDF)..... 22
 - Production Feeder..... 23
 - High Capacity Vertical Stacker..... 24
 - Side Exit..... 25
 - Catch Tray..... 25
 - Automated Insertion Management System (AIMS)..... 26
 - Shut Down the System..... 26

- 4 Working with Jobs 27**
 - Introduction..... 27

Use an Existing Job.....	27
Create a New Job.....	28
About Automatic Jobs.....	29
Create an Automatic Job.....	29
Create a Manual Job.....	30
Create a test mail set.....	42
Mail Sets.....	48
Change to Another Feeder Tray.....	53
Link Feeder Trays.....	54
Edit a Job.....	55
Save a Job.....	55
Delete or Move an Enclosure.....	56
Copy a Job.....	57
Delete a Job.....	57
Rename a Job.....	58
Lock a Job.....	59
5 Loading the System	60
Document Orientation.....	60
Document Feed Trays.....	61
Loading Envelopes.....	72
Fill the Sealing Liquid Reservoir.....	75
6 Settings menu	77
Changing screen display.....	77
Open the Operator Settings Menu.....	78
The Supervisor Settings Menu.....	80
Supervisor Settings Menu.....	80
7 Connect the System to the Internet	100
Options for Connection.....	100
Set up a Wired Connection.....	100
Set up a Wireless Connection.....	101
Test the Connection.....	104

	Ping test.....	105
	Preferences.....	106
	AIMS settings.....	106
8	Reading	108
	Introduction.....	108
	BCR Code Description.....	109
	OMR Code Description.....	115
	Flex Reading Code Description.....	118
	Create Jobs with Reading.....	118
	Reading Settings.....	122
9	Operator Maintenance	124
	Maintenance Schedule.....	124
	Clean and Replace Brushes.....	125
	Replace or Clean Moistening Cloth.....	126
	Calibrate Photocells.....	127
10	Fault Finding	130
	Messages.....	130
	Clearing stoppages.....	133
	Operator Troubleshooting.....	136
	Troubleshooting table.....	136
11	Specifications	141
	System Specifications.....	141
	Hopper and Feeder Capacity.....	142
	Configuration Dimensions and Weight.....	142
	Document and Enclosure Specifications.....	143
	Envelope and Document Set Specifications.....	143
	Production Feeder Specifications.....	145
	High Capacity Vertical Stacker Specifications.....	146
12	Terminology	147
	Terminology.....	147

1 Read this First

Safety



Ensure you have read and fully understood the safety requirements in the [Safety Guide](#).

Declaration of Conformity (EU only)

The product presented in this guide meets the requirements of applicable directives. For more details refer to the Declaration of Conformity. Contact your authorized distributor for availability of this document.





About this manual

Disclaimer

This Guide is published without any warranty. Improvements and changes to the online Guide necessitated by typographical errors, inaccuracies of current information, or improvements to programs and/or equipment, may be made at any time and without notice.

Symbols

This manual uses the symbols listed below.

This symbol...	Indicates...
	WARNING: Indicates a human safety hazard.
	ATTENTION: A risk to the equipment or mail could result from an action you may perform.
	NOTE: A remark that explains different cases or specificities.
	TIP: Advice to help save you time when processing your mail.
	SUPERVISOR: Indicates that you have to use the supervisor menu to perform the procedure.

Languages

In the EU the user guide must be available in the national language(s) of the country where the system is delivered. Therefore, if the User Guide is not available in your country's language(s), contact your authorized distributor.

Software

The software used for the reading option is based in part on the work of the Independent JPEG Group.

2 How this Help Works

Help Menu

The help button [?] gives access to help topics via a pull-down menu.

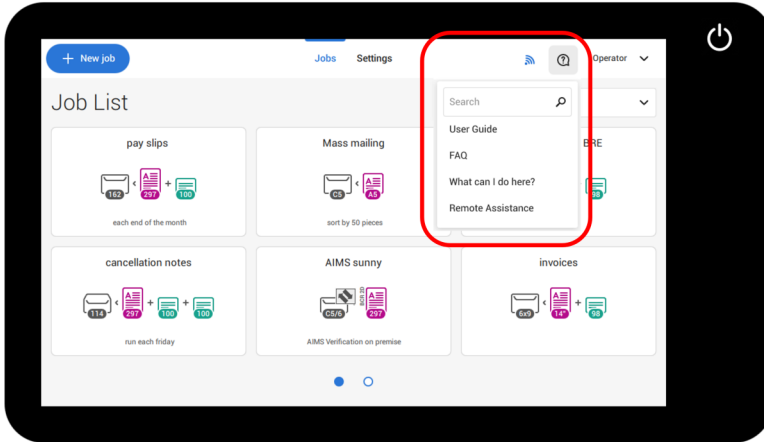

The contents of the help menu can be different for your situation. The help menu can contain the following topics:

- Search: use the search engine to find a specific topic.
- User Guide: user instructions describing how to use the system.
- FAQ's (option); when the system is connected to the internet, frequently asked questions are answered here (option).
- What can I do here: a list with relevant help topics related to the current screen.
- Remote assistance (option): online remote assistance for helpdesk guidance. Call the phone number that is displayed and follow the instructions of the support assistant.

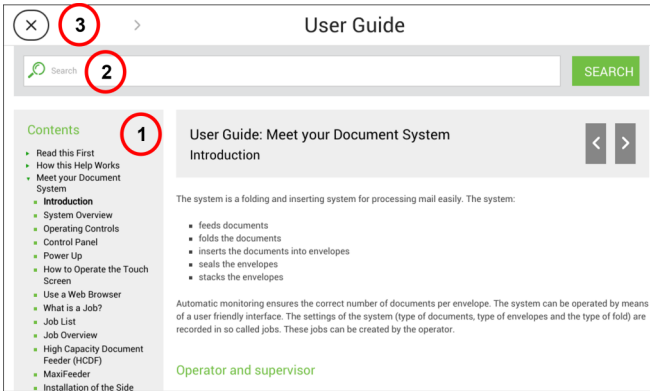

You can use this guide as follows (see example English User Guide):

1. Use the contents overview to browse the contents.
2. To search for topics; enter a keyword in the Search bar and press the Search button.
3. When you are finished you can close the User Guide with the Close button (X).

To navigate through the User Guide:

- Tap to select.
- Swipe up/down to scroll.
- Double tap to zoom.
- Pinch in/out to zoom in/out.

See also [How to operate the touchscreen](#) on page 12.

3 Meet your Document System

Introduction

The 6308 is a folding and inserting system for easily processing mail. The system:

- feeds documents
- folds the documents
- inserts the documents into envelopes
- seals the envelopes
- stacks the envelopes

Automatic monitoring ensures the correct number of documents per envelope. The system can be operated by means of a user friendly interface. The settings of the system (type of documents, type of envelopes and the type of fold) are recorded in so called jobs. These jobs can be created by the operator.

Operator and supervisor

You can use the system as operator and as supervisor. The supervisor has access to more settings than the operator. You can switch from operator to supervisor in every screen. When you switch to supervisor, you see immediately the result: extra tabs appear for the advanced settings.

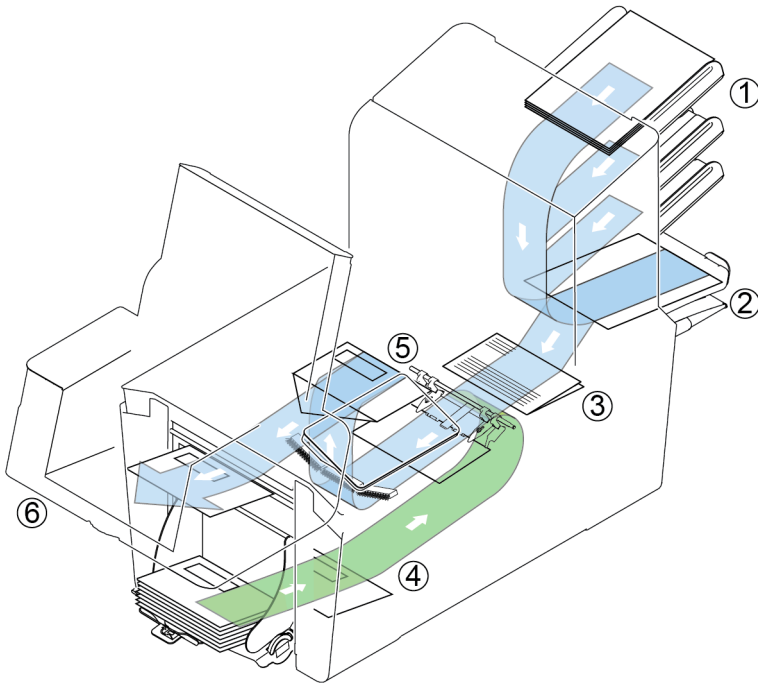

The figure shows an overview of the system.

Document Feeders (1)

The Feeder is the feeding part of the system. There are two types of feeders: the automatic and the special feeder. The automatic feeder does not require any adjustments for separation. From a feeder you can feed one or more documents (multi feed). The feeders have a double feed control (DFC). DFC detects if more documents are fed instead of one. You can link feeders. This means that two feeders can be linked as pairs. When the first feeder is empty, the system switches to the other feeder. Meanwhile the empty feeder can be refilled without stopping the system.

The upper automatic feeder is equipped with a 'daily mail' function. You can use this feeder to process sets of documents that you cannot process automatically (stapled documents and sets with varying thickness).

Collating Area (2)

All documents of a document set are collated and aligned in the collating area.

Folder unit (3)

The fold unit folds the documents. The following fold types are possible (see [Terminology](#) on page 147):

- No fold
- V-fold
- C-fold
- Z-fold
- Double V-fold

Envelope feeder (4)

Envelopes that are placed on a stack by the user, are fed one by one into the system by the envelope feeder.

Inserter (5)

After the documents are folded, the documents are transported to the inserter. The inserter inserts the documents into a waiting envelope. The inserter seals the envelope or not, depending on the settings.

Stacker (6) (optional)

The documents inserted (or not) are transported to the stacker depending on the programmed job. The stacker automatically stacks inserted documents.

Operating Controls

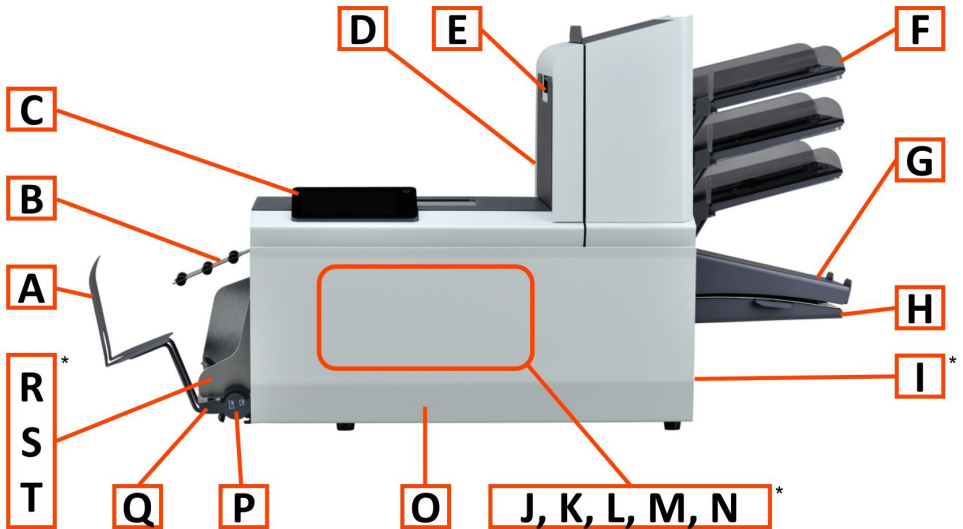

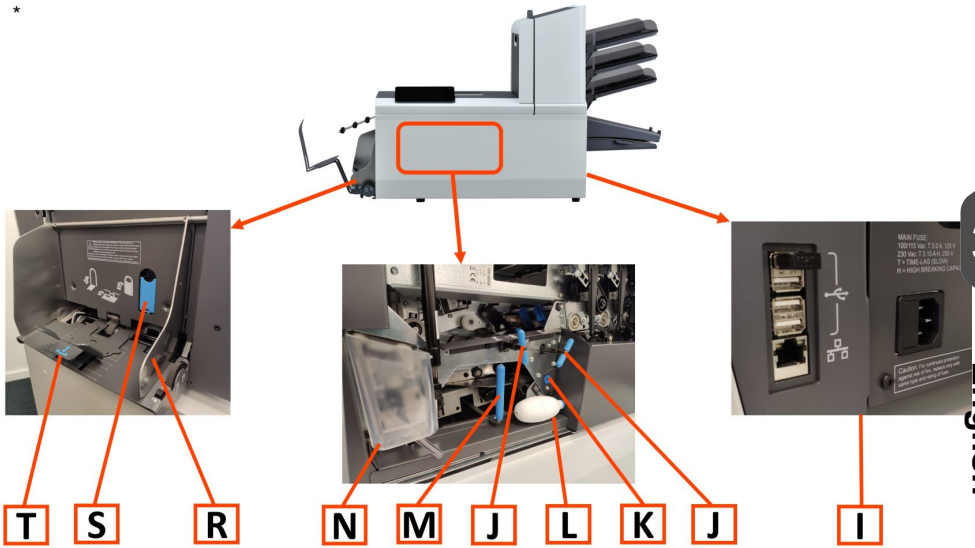

A - Envelope catch tray (optional)	K - Sensors
B - Envelope slide (optional)	L - Bellows
C - Display with operating buttons	M - Handle for clearing jams
D - Upper unit	N - Sealing liquid reservoir
E - Locking hand grip upper unit	O - Front cover (ruler at inner side)
F - Document feeders	P - Thumb wheel for side guide adjustment
G - Collator arm	Q - Locking knob for thumb wheel
H - Collator area	R - Envelope hopper side guides
I - Power inlet, USB, LAN	S - Separation adjustment knob
J - Knobs for clearing jams	T - Envelope support bracket

Control Panel

3

English



On/Off (B): The touch sensitive button in the upper right corner of the display switches the system on or off. If the system is not used for one hour, the system switches off to safe power.

Status LED (C): A status LED indicates the state of the machine, a green LED indicates that the system is switched on, a blinking red LED indicates the system is switched off.



The display is a capacitive touch screen. To avoid permanent damage of the display, do not use sharp objects to operate the display.



To clean the display use a dry lint-free or microfiber cloth. If water is necessary to clean the screen, you should make your microfiber cloth slightly damp instead of putting the water directly on your screen. Never use large amounts of water, harsh chemicals, abrasive cloths or paper towels to clean the display.

Power Up

To start up the system:

1. Connect the system to the mains power supply.



You can severely damage the machine if it is connected to the incorrect mains voltage. Before plugging in the machine, check if the local voltage is the same as the voltage mentioned on the type plate.

2. Press the on/off button next to the display.



In case the system is unresponsive or fails to switch off, press and hold the touch sensitive power button for 10 seconds to switch off the system.

The touch screen shows the Job list screen.

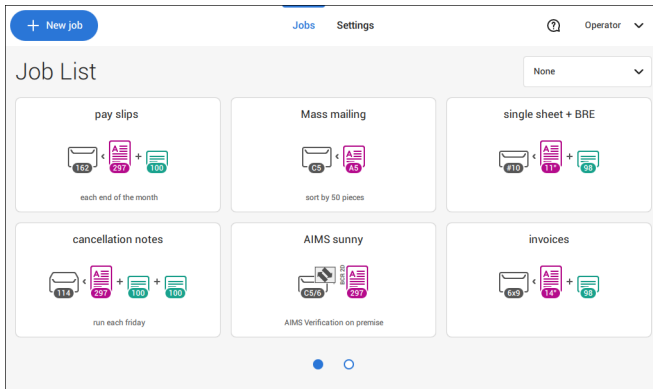

How to Operate the Touch Screen

You can operate the touch screen like a tablet:

- **Tap** : touch and release the screen with your finger.
- **Swipe**: touch the screen, hold it and move your finger(s) left, right, up or down.
- **Tap and hold**: touch the screen with your finger and hold it for two seconds.
- **Pinch out/in**: to zoom out/in. Only available in help/content browser.

Tap

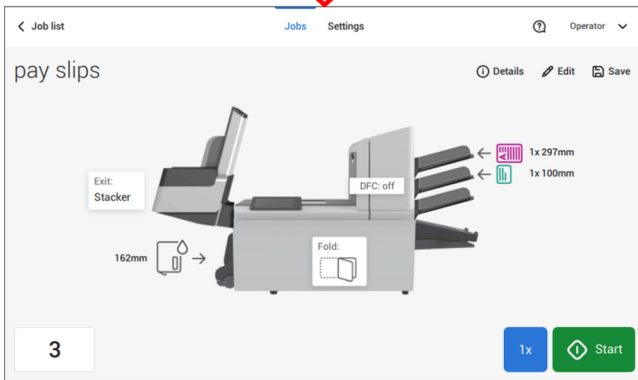
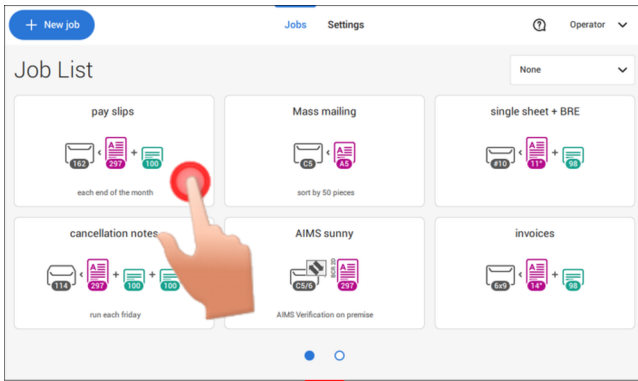

Swipe

3

English

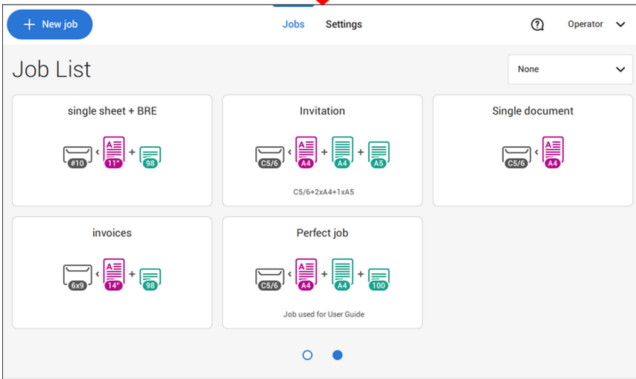
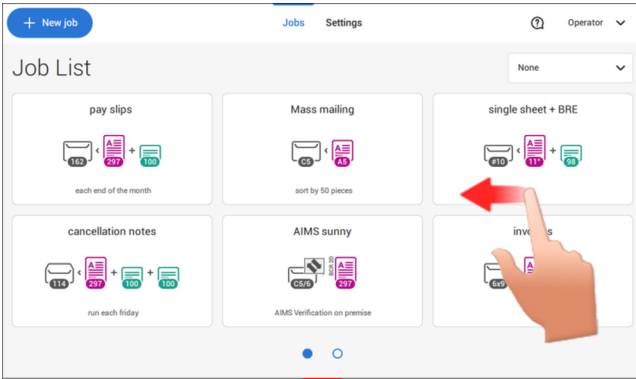

Tap and hold

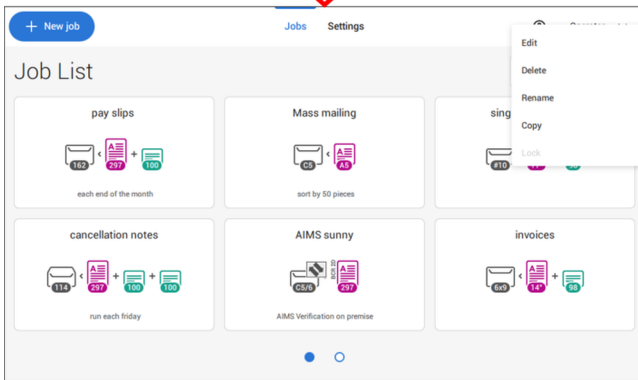
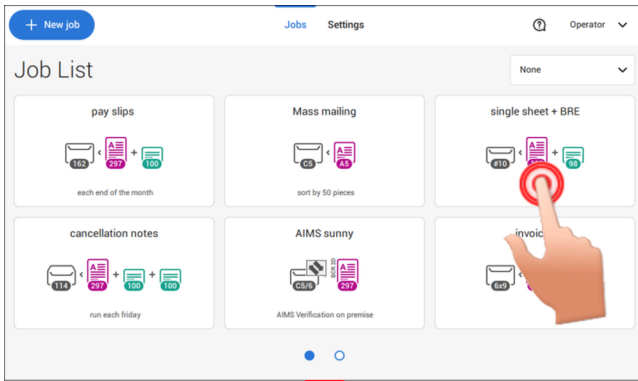

Pinch out / pinch in (only available in help/content browser)

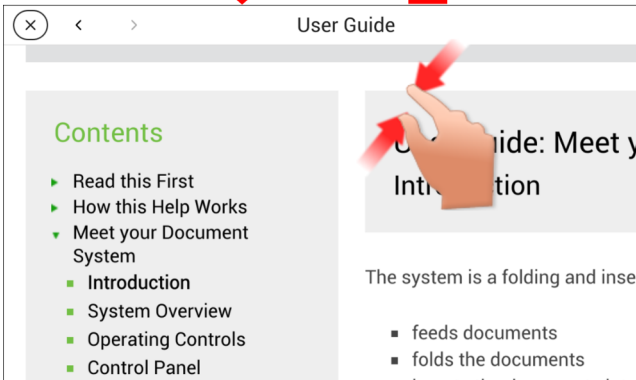
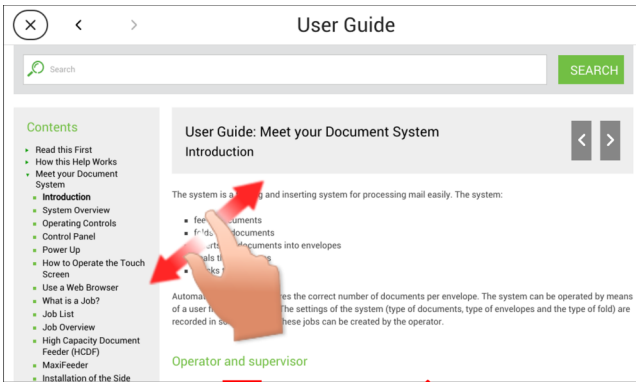

What is a Job?

If you have to process a lot of mail sets of the same type (for example bills), you can save the settings to a 'job'. The next time you just select the job and immediately start without defining any settings.

The following settings are saved in a job:

- Envelope type/size;
- Sealing on/off;
- Which document feeders should be used, how many documents should be fed from each feeder and document height for each feeder;
- Feeder linking on/off;
- If BREs or insert cards should be included;
- Address position;
- Fold settings;
- Double feed control settings;
- Reading settings (option);
- Stop counter, also known as Batch counter, defining the number of mail sets that the job must process. The job will automatically stop processing when this number is reached.

Job List

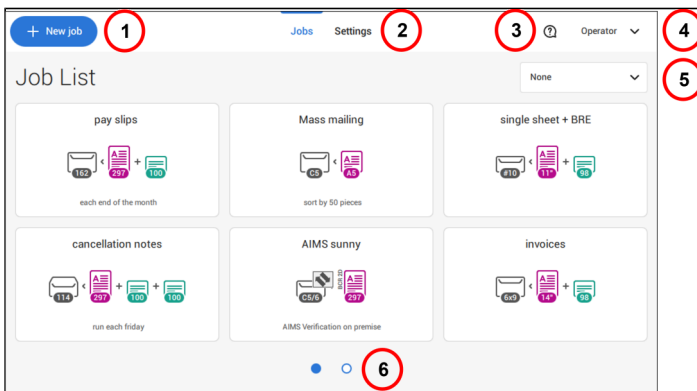

When you start up the system, the 'Job list' menu appears. Here you can do the following:

1. Tap (1) if you want to create a new job.
2. Tap (2) to open the (Operator) Settings menu. When you are logged in as supervisor, the settings menu is extended with advanced settings (see [Settings menu supervisor](#) on page 80).
3. If you need help tap the question mark (3) for the Help menu. See also [Help menu](#) on page 3.
4. Tap (4) to get access to the Supervisor or Service menu. See [Introduction](#) on page 6.
5. Tap (5) to change the Job list sorting.
6. Tap (6) to switch between the available job list screens.

If you want more information on a job, select the job. With the **[Job list]** button you get back to the home menu.

See also: [Working with Jobs](#) on page 27.

Job Overview

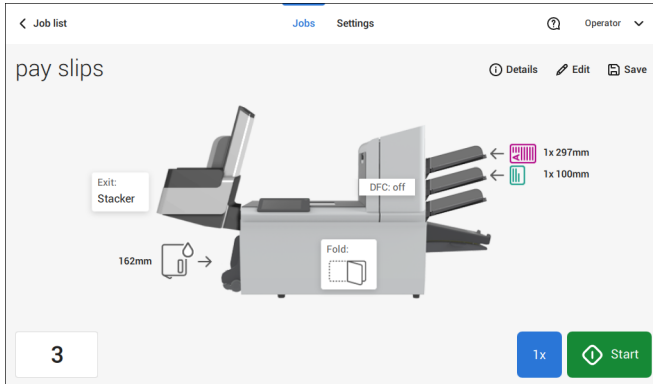

If you want more information on a job, select the job in the Job List.

The touch screen shows the following information of the selected job:

- Job name
- Job settings (for example the document and envelope type)
- How to load envelopes and documents for this job
- The number of envelopes that have been processed with this job

In this screen you can change the following settings:

- Counter settings (see [Change the counter settings](#) on page 38)
- Job settings (see [Editing a job](#) on page 55)
- Move documents between feeders (see [Change to an other feeder tray](#) on page 53)
- Link feeders (see [Link feeder trays](#) on page 54)
- Start the job or run a test run (see [Create a test mail set](#) on page 42)



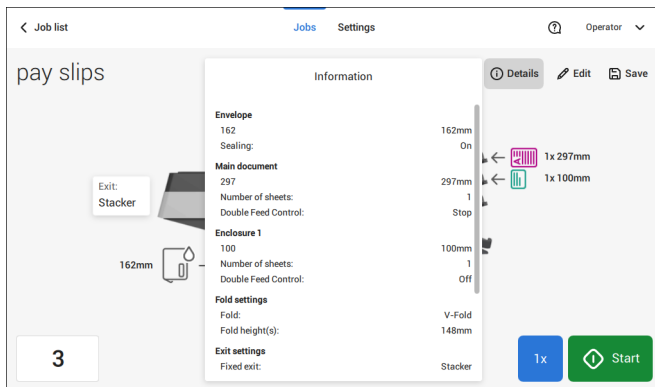







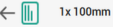

If you tap "(i) Details" a summary of all information of the job is listed.











3

English

The following is a list of symbols or icons and their descriptions.

	<p>Main document. Shows the correct document orientation; A is the address.</p>		<p>Document with reading Shows the correct document orientation; A is the address.</p>
	<p>Daily mail Feature to manually insert mail-sets one by one into the system.</p>		<p>Enclosure</p>
	<p>Notification Next to an exclamation mark symbol, a message appears, e.g. Sealing liquid low, empty feeder.</p>		
	<p>Wired LAN connected Network connection is available via a network cable connection.</p>		<p>Wired LAN connected, no internet Network connection via a network cable is available but the network is not connected to internet. Check with your network administrator.</p>
	<p>Wired LAN not connected Network connection is not available via a network cable connection.</p>		<p>Wireless LAN connected Network connection via Wireless network is available.</p>
	<p>Wireless LAN connected, no internet Network connection via Wireless network is available, network is not connected to internet. Check with your network administrator.</p>		<p>Wireless LAN not connected No network connection to Wireless network or Wireless network out of range.</p>
	<p>Envelope, sealing on Envelopes will be sealed. The symbol shows the correct envelope orientation.</p>		<p>Envelope sealing off Envelopes will not be sealed. The symbol shows the correct envelope orientation. When sealing is off, the flap of the envelope is closed but not moistened.</p>

	<p>Feeder linking</p> <p>Linking means that when one feeder is empty, the system automatically starts feeding documents from the other feeder. This symbol at the feeders shows if the feeders are linked.</p>		<p>Change feeder trays</p> <p>Possibility to change from one feeder tray to another.</p>
DFC: off	<p>DFC</p> <p>Double Feed Control has been set to 'off'. By default the DFC will be set to 'on' and the text will not be shown.</p>		<p>Fold type</p> <p>This icon shows what kind of fold type has been set.</p>
Exit: Stacker	<p>Exit setting</p> <p>This icon shows what kind of exit setting has been set.</p>		<p>Counter setting</p> <p>Shows on what number the counter has been set.</p>
	<p>1x button</p> <p>After tapping this button the system will create an example mail set.</p>		<p>Start button</p> <p>Tapping this button runs the job.</p>
< Job list	<p>Job list button</p> <p>After tapping this button the job list screen will be shown.</p>		<p>Stop button</p> <p>Button to stop the system The current mail set will be completed and the system stops, being empty and ready for a new set.</p>
	<p>Edit button</p> <p>Gives access for editing a job.</p>		<p>Save button</p> <p>Save the job or changes that have been made to a job.</p>

High Capacity Document Feeder (HCDF)

3

English



The High Capacity Document Feeder (HCDF) is an option that can be delivered from factory. The High Capacity Document Feeder has a capacity for up to 725 sheets. The standard document feeder tray has a capacity of 325 sheets.

For more information on the operation of the HCDF, refer to the topic on [loading documents for the HCDF](#) on page 71.

MaxiFeeder



The Production Feeder can be loaded with a high number of documents. This feeder is intended to be used for Business Reply Envelopes (BRE), but also 'standard' documents up to 156mm (6.1") length can be processed with it.

For more information on the operation of the Production Feeder, refer to the topic on [loading documents for the Production Feeder](#) on page 68.



A license is required if you want to use the Production Feeder for documents longer than 156 mm (6.14").



In case of long documents an A4 or 11" support plate is available for supporting these longer documents. Ask your local distributor for more information about these optional support plates.

High Capacity Vertical Stacker

3

English



The High Capacity Vertical Stacker can be used to stack filled envelopes. The vertical stacker can store up to 325 filled envelopes. To adjust the side guides on the High Capacity Vertical Stacker, follow these steps:

1. Adjust the side guides with wheel **A** until a margin of 3 to 5 mm is left between the envelopes and the side guides.

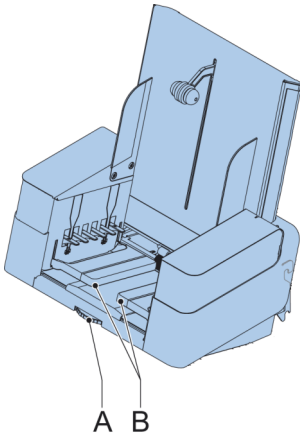

2. For small envelopes it can be necessary to remove the extensions **B** from the envelope support.
-

Side Exit (optional)



The system can be equipped with a side exit and catch tray. The side exit allows a conveyor or a franking system to be fitted in line with the system. The side exit can also be used with a catch tray to achieve vertical stacking (see picture). The catch tray is delivered with the side exit.

The side exit is available in two versions LH/RH, either transporting the envelopes to the front or back of the system.

Catch Tray



The system can be equipped with a "basic" Catch Tray at the exit. When the Catch Tray is fitted, documents (inserted or not) will be transported to rear exit.

Automated Insertion Management System (AIMS)

The Automated Insertion Management System (AIMS) is an optional software feature. AIMS is a software system that monitors the progress of documents in real-time through a Document System (Folder-Inserter) providing various levels of reporting. In addition to reporting on the documents being processed by the Document System, it can also report on the performance of the system or systems processing the documents.

Contact your local distributor to find out if this feature is available for your organization.

Shut Down the System

1. Press the **[On/Off]** button to shut down the system.



In case the system is unresponsive or fails to switch off, press and hold the touch sensitive power button for 10 seconds to switch off the system.

When the system is busy, it completes and inserts the current set, stops and will be shut down.

4 Working with Jobs

Introduction

With the system you can process mail sets in the following ways:

- **Using an existing job:** Existing jobs are shown in the Job list and saved via the 'automatic' or 'manual' job creation process. How to use an existing job is described in [Using an existing job](#) on page 27.
- **Automatic job:** The system automatically picks one sheet from each filled feeder and processes them into mail sets. The automatic feature is described in [About Automatic jobs](#) on page 29.
- **Manual job:** various settings, not available in an Automatic job, can be set in a 'manual job. This includes the use of daily mail. Working with manual jobs is described in [Create a manual job](#) on page 30.

Use an Existing Job

If you want to use an existing job:

1. Open the job list.
2. Tap the job you want to use.

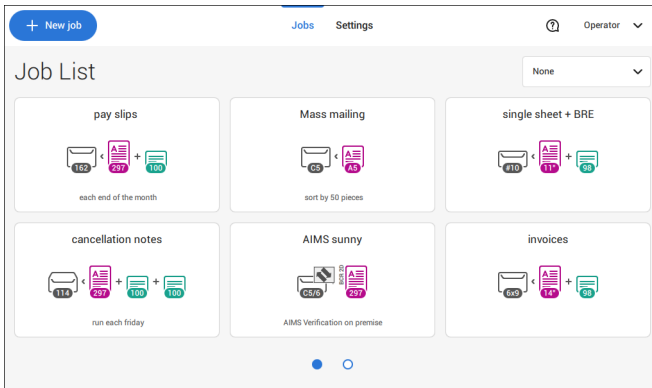

3. Load the feeders as shown on the display.
4. Tap [1x] to create a test mail set, see [Test mail set](#) on page 42.
5. Check the Test mail set.

- If the Test mail set is OK: tap **[Start]**.
If the Test mail set is not OK: adjust the address position or envelope stop position or check and re-adjust the job settings.



If desired tap the counter button to set the counters. See [Counter settings](#) on page 38.

- Tap **[Start]** to start the job.
- Tap the **[Stop]** button to finish the job.
- Tap **[Job list]** to return to the job list.

Create a New Job

To create a new job:

- From the Job list, tap **[New job]**.
- Choose **[Automatic]** or **[Manual]** to create a new job.

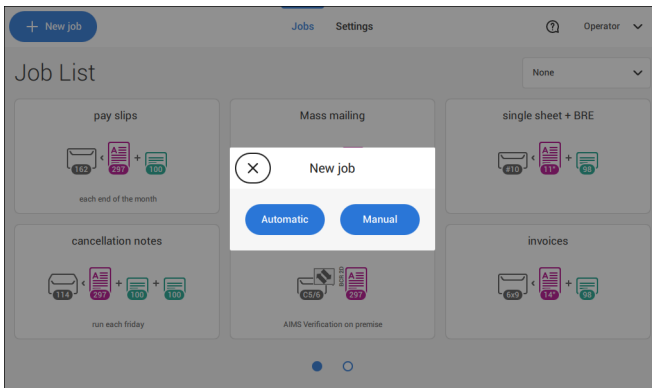

- If you choose 'Automatic' follow the description as can be found in [Create an Automatic job](#) on page 29.
 - If you choose 'manual' follow the description as can be found in [Create a Manual job](#) on page 30.
-

About Automatic Jobs

You can save every automatically created job and edit it like any job.

An Automatic job processes mail sets according to the following rules:

- The machine picks one sheet from each filled feeder;
- The picked documents will be folded (if necessary) and inserted into an envelope;
- Only the Double Feed Control (DFC) of the upper feeder will be selected (this is done automatically).

The following features are not supported with Automatic job processing.

- Linked feeders (the option where, if one feeder is empty, the system automatically continues using another feeder);
- Multiple sheet feeding (picking more than one sheet from a certain feeder);
- Daily mail;
- Reading functionality;
- No envelopes (use envelopes yes/no).

If you want to use any of these features, you have to use Manual jobs to process the mail set or edit the job afterwards.

Create an Automatic Job

Proceed as follows if you want to create an automatic job:

1. From the Job list menu, tap **[New job]**.
2. Tap **[Automatic]** to start an Automatic job.

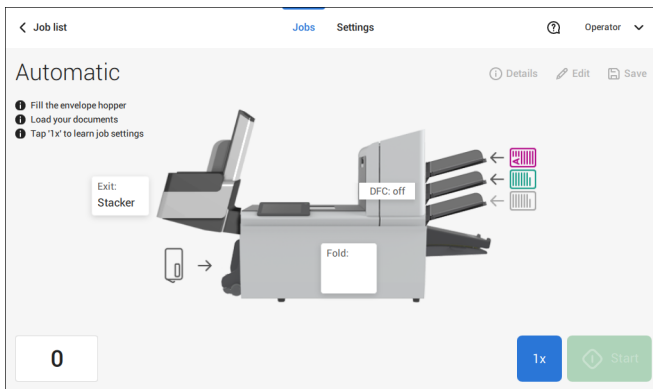

3. Fill the envelope hopper, load your documents and tap **[1x]** to create an example mail set.

4. Make sure that the address position and the envelope stop position are correct. If not, [adjust the address position](#) on page 46 and [envelope stop position](#) on page 43.
5. If necessary, tap the counter symbol to set the counters. See [Counter settings](#) on page 38.
6. Tap **[Start]** to start the job.
7. Tap **[Stop]** to finish the job.

Tap **[Save]** if you want to save the settings of the Automatic job to a new job.

Create a Manual Job

Introduction

Creating jobs manually is easy: the user interface guides you through the job definition with clear steps.

These steps are:

- Define the mail set: envelope type, main document and optional enclosures.
- Define how to fold the document set.
- Define the exit of the system that should be used for this job.

Create a Manual Job

To create a job manually:

1. From the Job list, tap **[New job]**.
2. Choose **[Manual]** to define the job settings.

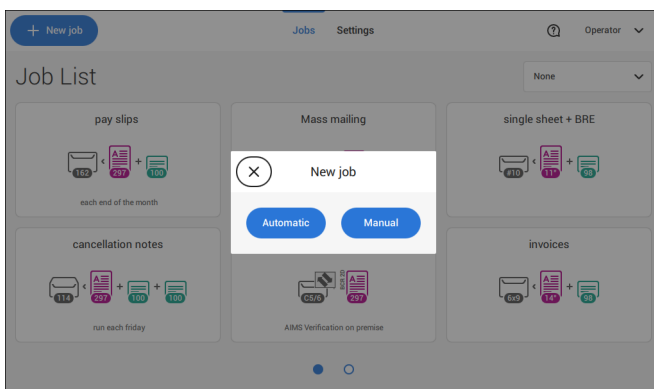

Continue with the envelope settings (see [Select Envelope](#) on page 31).

Mail Settings

Select Envelope

1. Tap **[Envelope]**.

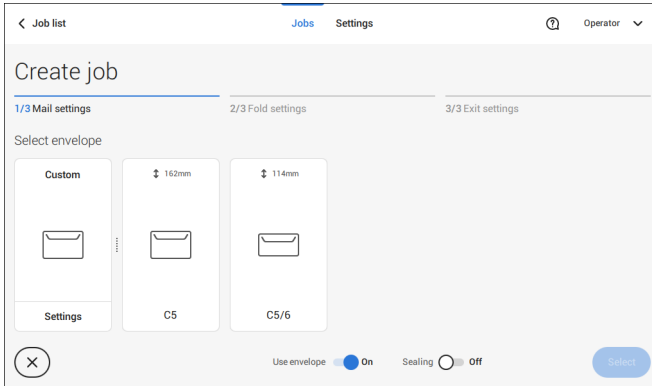

2. Select a predefined envelope or [create a custom envelope](#) on page 50.

Optionally tap **[Use envelope]** to set the use of envelopes to 'off' if you want to Create a job without the use of envelopes.

3. Tap **[Sealing]** to switch it on or off.



By default the envelopes will be sealed.

4. Confirm the envelope settings with **[Select]**.

Continue with the main document settings (see [Select Main Document](#) on page 32).

Select Main document

1. Tap **[Main document]**.

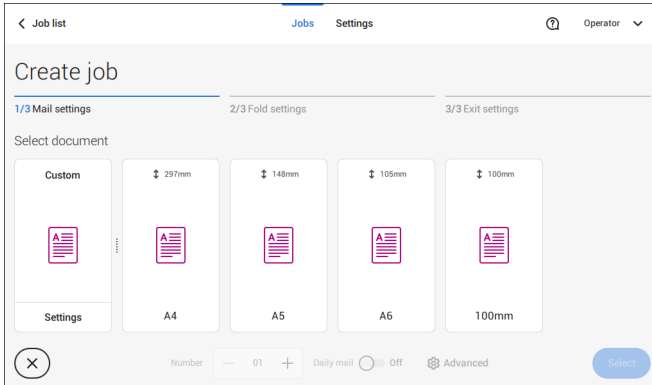

2. Select a predefined document or [create a custom document](#) on page 52.
3. Change the **[Number]** to add more than one document from a feeder (multiple sheet feeding).
4. Optionally tap Daily Mail to set Daily Mail to 'on' (see also [Daily Mail](#) on page 49) or tap **[Advanced]** to set the DFC settings (refer to [DFC Settings](#) on page 32).
5. Confirm the document settings by tapping **[Select]**.

Continue with the [Enclosure settings](#) on page 33.

Switch DFC on or off for feeders

For every feeder you can switch the double feed control (DFC) on or off.

To change the DFC settings:

1. Tap the job that you want the change the DFC settings for.
2. Tap **[Edit]**.
3. Tap the document that you want to change the DFC for.

4. Tap **[Advanced]**.

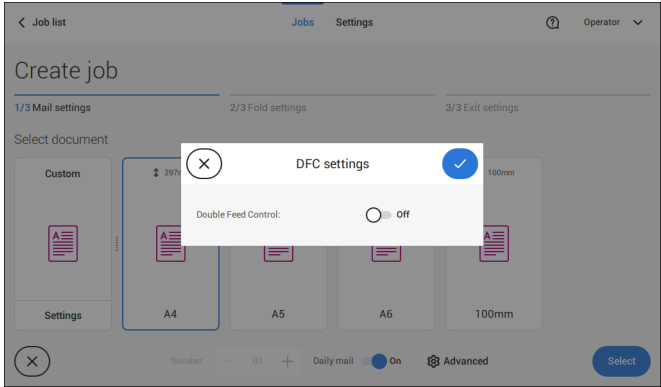

- 5. Tap Double Feed Control to switch it on or off.
- 6. Confirm the settings by tapping **[Select]** and continue with the document settings.

Select an Enclosure

1. Tap **[Add enclosure]**.

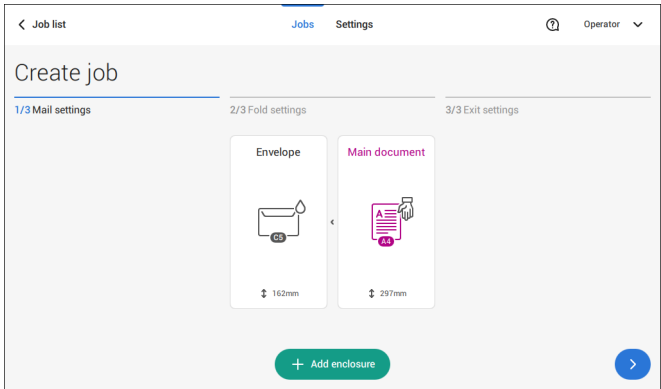

- 2. Select a predefined document or create a custom document as your enclosure (see [Create a custom document](#)) on page 52.
If you want to remove an enclosure from the job, or change the order of the enclosures, see [Delete or move an enclosure](#) on page 56.
- 3. Change the **[Number]** for more than one document from a feeder.
- 4. Confirm the enclosure settings by tapping **[Select]**.

Continue with the fold settings (see [Fold settings](#) on page 34).

Fold Settings

Default the system suggests the most logical fold type. This fold type is highlighted. However, you can select other fold types and change their settings.

1. Tap a fold type.

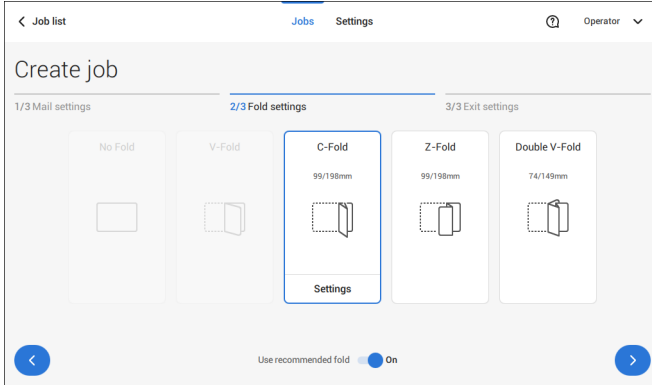

2. If necessary, tap [**Settings**] to change the fold settings.
3. Tap [**>**].

If you want to revert to the machine recommended fold type, switch [**Use recommended fold**] to On.

Continue with the exit settings (see [Exit settings](#) on page 34).

Exit Settings

1. In Exit Settings the Fixed exit is selected by default.

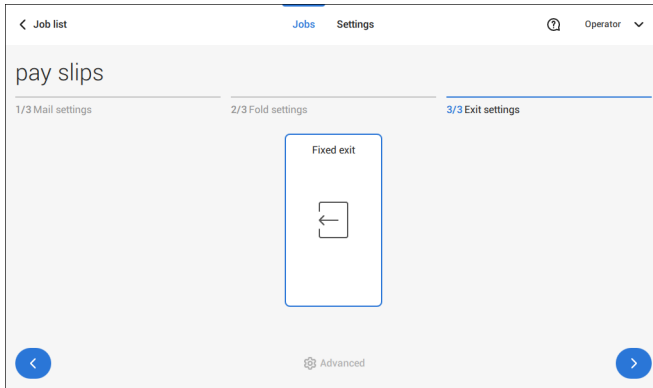

2. Optionally tap the [**Advanced**] button to set the Advanced settings per job.
3. Tap [➤].

Finish the job definition and start the job (see [Finish the job definition and start the job](#) on page 40) or set the Counters (see [counter settings](#) on page 38).

Job Settings (per job)

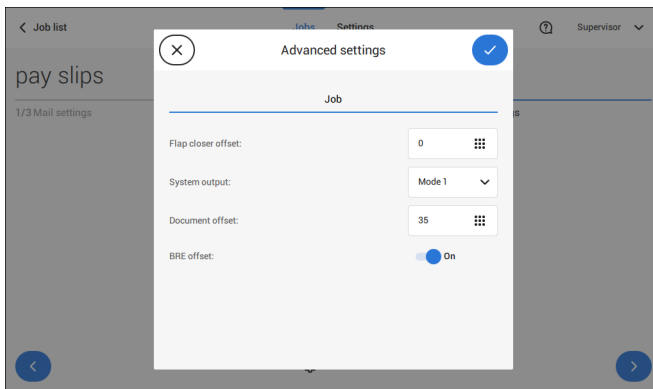

The Job settings part of the "Advanced settings" menu covers settings that improve the processing of jobs:

- **Flap closer offset:** to improve the sealing of specific envelopes you can delay or advance the moment of sealing. You enter the number of pulses. A minus value means the sealing is advanced, a plus value means the sealing is delayed. You can enter a number between -20 and 20.
- **System output:** mode 1 mode 2
 Mode 1 focuses on the versatility of paper parameters (paper thickness; document length), i.e. correct operation under even extreme paper conditions. Mode 2 is the default mode, and focuses on high speed. Use Mode 1 with a paper thickness of 65

g/m2 or less, a document length of 12 inch (305 mm) or higher, and for situations where Mode 2 is not functioning properly. In all other cases use Mode 2.

- **Document offset** (A in the figure): the extend to which documents are not overlapping in the vertical transport. In the vertical transport of documents fed by the various feeders, the documents are partially overlapping each other. This to make sure that the documents are properly aligned in the collator area. The default value is 50 mm (2.0 inch). The document offset can be varied between 20 mm (0.8 inch) and 250 mm (9.8 inch).

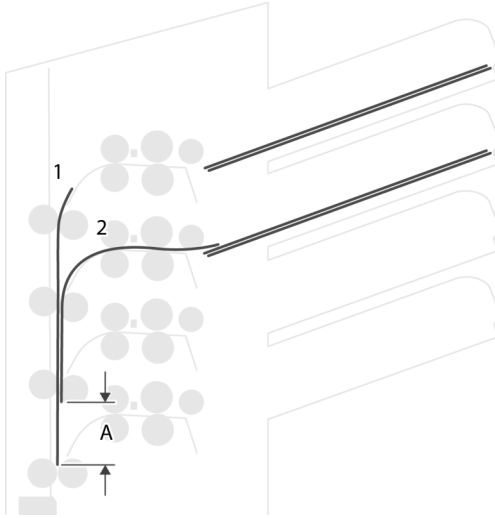

- **BRE offset:** in the case of offset is “yes”, the last document that was added to the set is shifted from the rest of the set (offsetting, see below).

Explanation of BRE offset: if a BRE is longer than the set fold but shorter than the envelope height, this BRE can get folded (A in the figure). Under certain conditions (see below) you can prevent the BRE from being folded. In the case of offset “yes”, the BRE is held back during a certain distance (B in the figure). This means that the trailing edge of the BRE leaves the collator last. The document is not folded. During the insertion into the envelope the documents of the set are aligned.

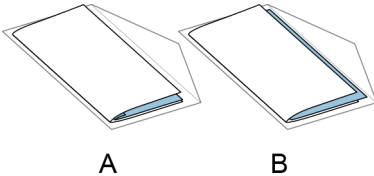

The conditions are:

- No multi-feed is used for the BREs.
- The document directly under the BRE must have a height of at least 60 mm (2.4 inch) more than the BRE.
- The height of the BRE is more than the set fold length.
- The folding mode is either V-fold or C-fold (no Z-fold).
- The BRE must be shorter than the envelope height.

The whole BRE offset is based on friction between documents within a set. Therefore it is necessary to make use of these conditions to reduce the risk of bad transporting, folding and inserting.



It is possible to use the BRE offset for a BRE and an enclosure (card) in one set. The extra condition is that this enclosure is equal to or smaller than the set address fold and should be placed direct underneath the BRE in the set.

AIMS settings

In case AIMS Mailpiece Id and Job Id is used in a barcode definition, the "Verification" mode can be enabled. When set to "Verification" all mail pieces will be verified with the AIMS server.

When switched to Off, the job will run normally but the mail pieces will not be verified with the AIMS server.

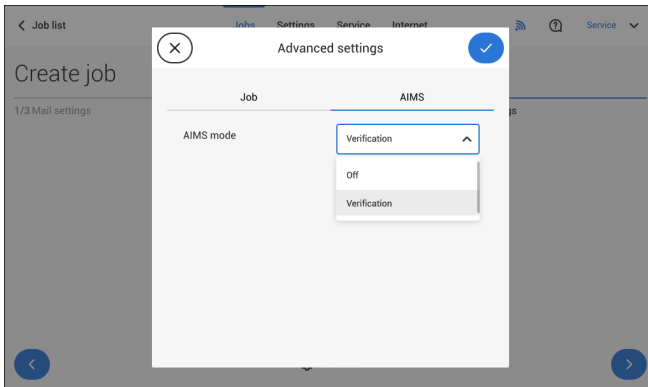

Change the Counter Settings



The counter settings are job related.

In the Counter submenu you can set the (daily) Job counter, the Stop counter and the Job total counter. The following will be shown in the Counter submenu:

- Job counter (as shown), the daily job counter: number of mail sets that have been processed using this job, after tapping [Start].
- Stop counter/Stop at value: set a number (of processed mail sets) after which the system stops processing. You can set from 5 through 9999. The system will continue processing mail sets until the job counter reaches the stop counter value. The system stops and can be restarted.
When the processing of mail sets has been interrupted the system shows how many mail sets have been completed. This is shown at 'completed so far'.
- Job total counter: total number of mail sets that have been processed using this job.

To reset/set the counters proceed as follows:

1. In the Job overview screen tap the counters button.

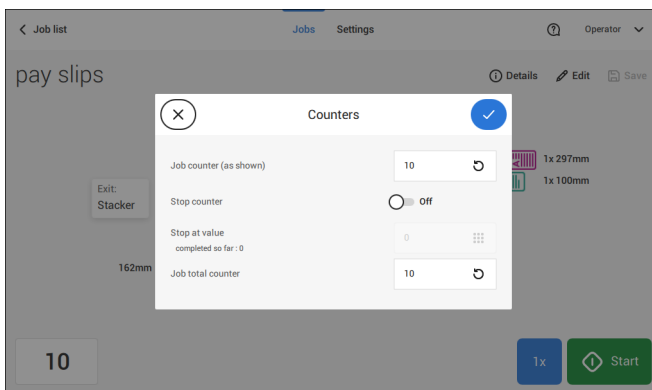
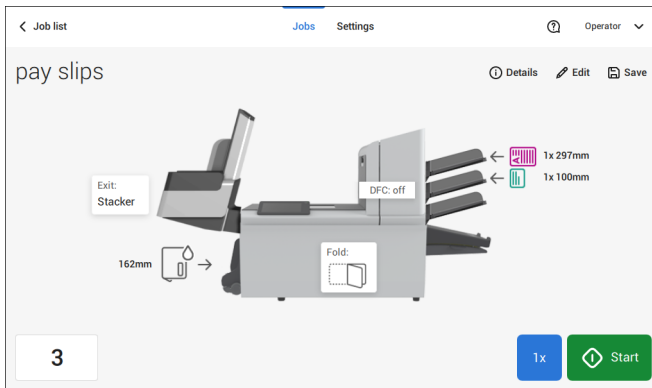

2. Tap the  button for the (daily) job counter to set it to zero.

3. Tap the **[on/off]** button to set the Stop counter to 'on' or 'off'.

If you set the Stop counter to 'on' you can enter the 'Stop at value'. Enter a value from 5 through 9999.



Be aware that when the system stops based on the stop counter, there can still be documents in the system. To clear the system from documents, remove the documents from the feeder trays and tap **[Start]** from the warning message; the remaining documents will be processed to clear the system.

4. Tap the  button for the Job total counter to set it to zero.



If you set the Job total counter to zero the number history of this job will be lost.

5. Tap **[√]** to go back to the job overview screen and tap **[Start]**.

Finish the Job Definition and Start the Job

When you have finished the exit settings, the touch screen shows an overview of the job settings.

In this screen you can change the following settings:

- Move documents between feeders (see [Change to an other feeder tray](#) on page 53)
- Link feeders (see [Link feeder trays](#) on page 54)
- Change the counter settings (see [Change the counter settings](#) on page 38)

When you are ready with these settings, proceed as follows:

1. Load the documents as indicated on the Job info screen (refer also to [Load the documents](#) on page 64).

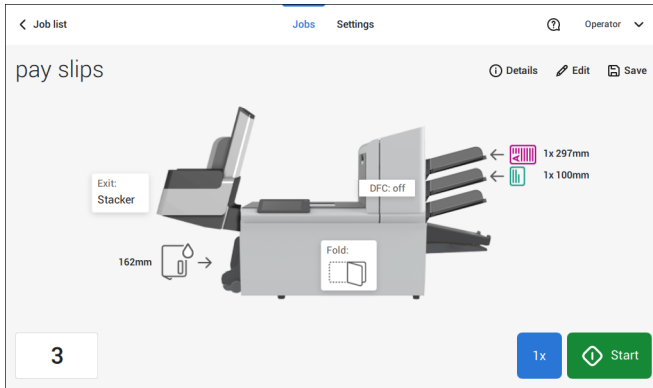

2. Tap **[1x]** to create a test mail set (see [Test mail set](#) on page 42).
3. If desired, you can save the job (see [Save a job](#) on page 55).
4. Tap **[Start]** to start the job.

Create a test mail set

Before starting an existing job or a new, manual created job, it is possible to create a test mail set.

This test run is intended to validate the settings of the Document System:

- Check if the address is correctly positioned behind the envelope window. See [Adjusting the Address position](#) on page 46.
- Inspect and adjust the stop position of the envelope. See [Adjusting the Envelope Insert fingers](#) on page 45.
- Check the fold settings for one set. See [Fold settings](#) on page 34.

When you tap the **[1x]** button, you can choose between test mail sets:

- Selected exit: creates one mail set that leaves the system at the defined exit. Use this option to test the complete process.
- Envelope stop position: separates one envelope and transports the envelope to the envelope stop position. Use this option to verify and adjust the envelope stop position.

After a test mail set, the system asks if the mail set is ok or not ok. When you select not ok, you are guided through a wizard that helps you to find the cause.

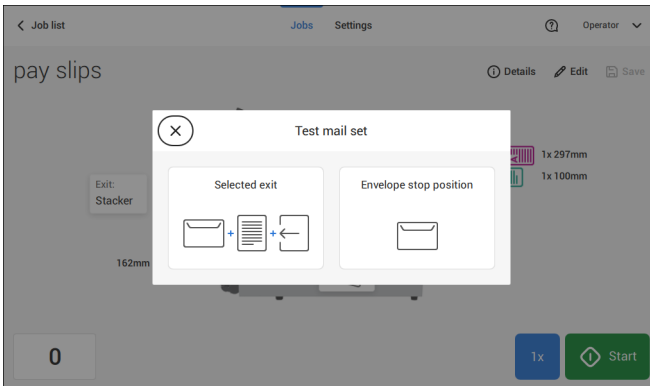

Verify the Insert Position



This adjustment must only be checked in case of problems or when changing the envelope type.

For the right Insert Position a correct alignment of the envelope flap fold line has to be applied. Proceed as follows:

1. Choose a job and tap **[1x]** (envelope only).
2. Tap **Envelope stop position**. The system will "fetch" an envelope.

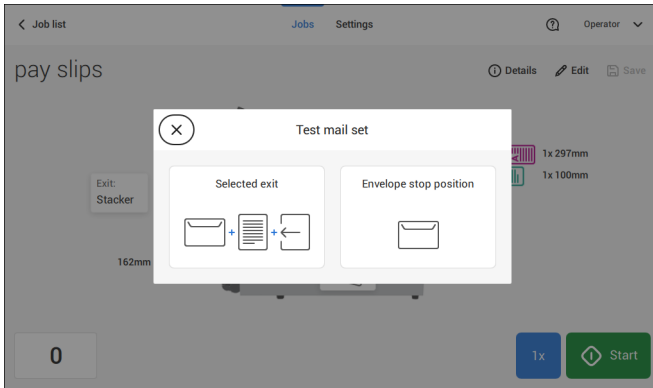

3. Unlock the unlocking lever A of the upper unit and pull up the upper unit.

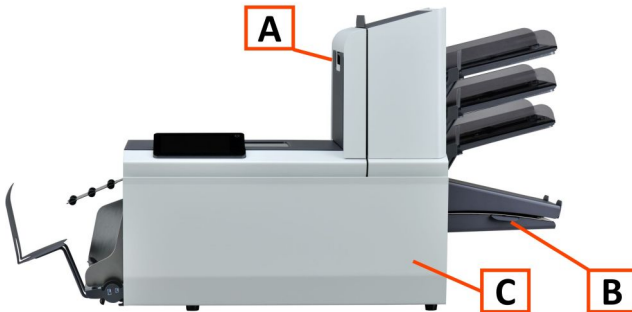

- Align the envelope flap fold line with the blue indicator by tapping the arrows.

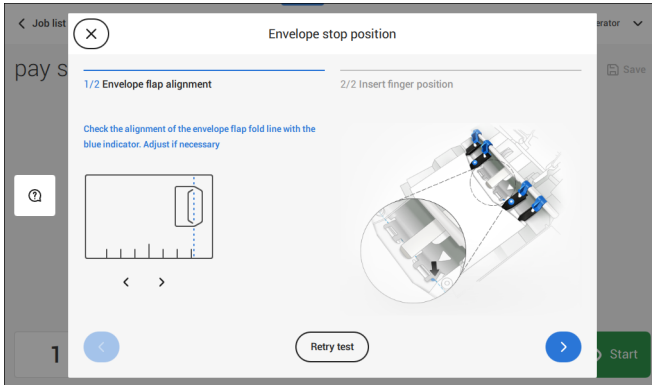

Tap the button **[Retry test]** to fetch another envelope (Note: the upper unit has to be closed). Check the alignment again. Tap the arrow in the bottom right corner if the alignment is OK.

- Position the insert fingers as indicated.

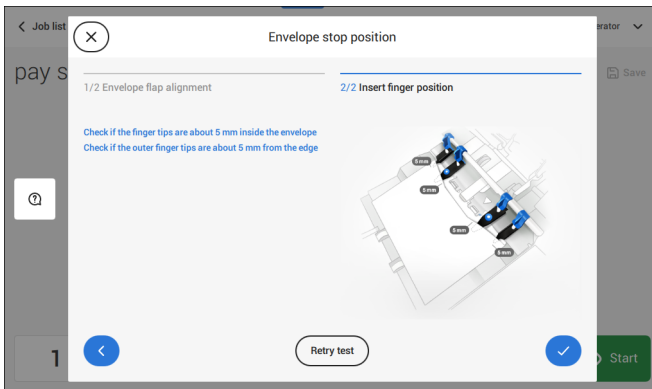

Tap the button **[Retry test]** to fetch another envelope (Note: the upper unit has to be closed). Check the positioning of the insert fingers again. Tap **[✓]** if the alignment is OK.

- Tap the envelope button to fetch another envelope.
- Make sure that the insert position is correct. If not, repeat the steps for adjusting the insert position.

Adjust the envelope insert fingers position

If the Insert fingers position is not correct, adjust the fingers as follows:

1. Loosen the knurled knob **C** on top of each finger.

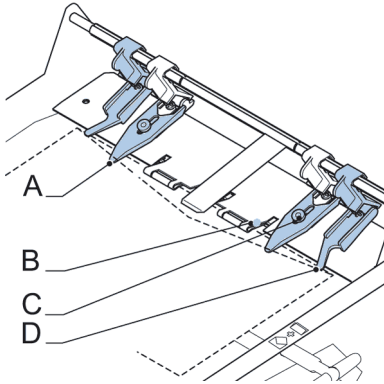

2. Adjust each finger **A** so that the tip enters about 5 mm (0.2 inch) into the envelope. The fingers can be moved sideways to the desired position.
3. Place the outer fingers **D** about 5 to 10 mm (0.2 to 0.4 inch) from the edges of the envelope.
4. Re-tighten the knurled knob.



Check the position of the insert fingers when changing to a different type of envelope.

5. Tap the envelope button on the touch screen to fetch another envelope.
 6. Make sure that the finger position is correct. If not, repeat the steps for adjusting the fingers.
-

Adjust the Address Position

If the address on your mail is not correctly positioned behind the envelope window, change the address position as follows:



Adjusting the address position is only possible after creating an example mail set (by using the [1x] button).

4

English

1. Choose a job and tap [1x].
2. Tap **Selected exit**. The system will "fetch" a mail set: an envelope and document(s).

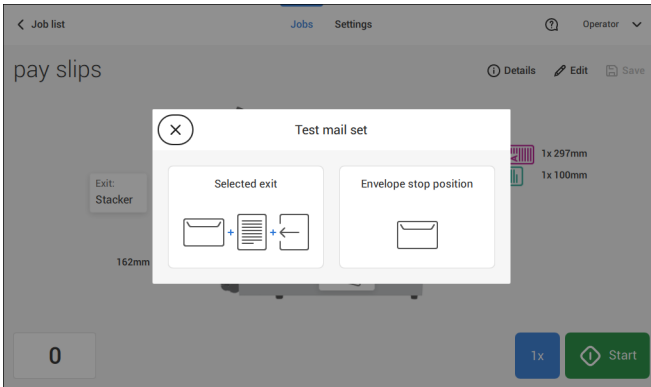

3. Tap **Mail set not OK**.

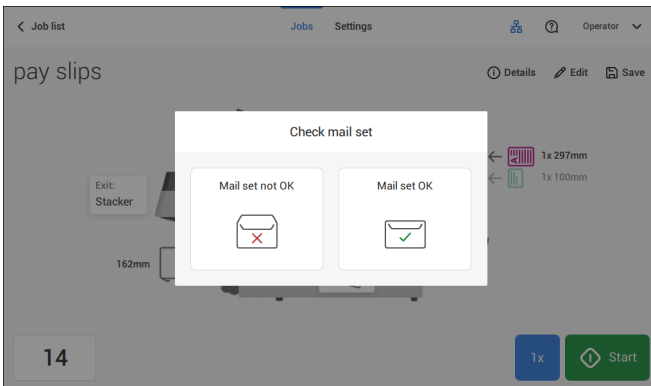

4. Tap **Address position not correct**.

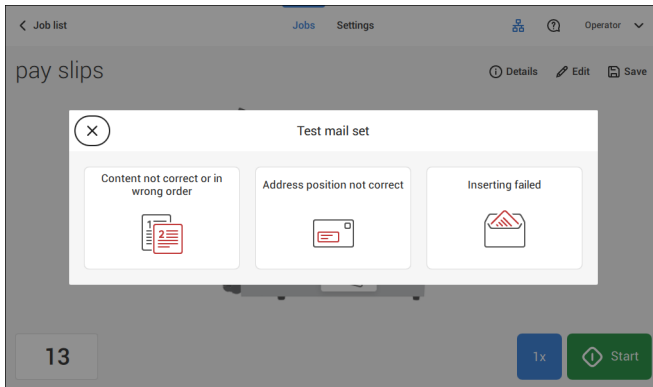

5. Change the address position: slide the position indicator to the correct position.

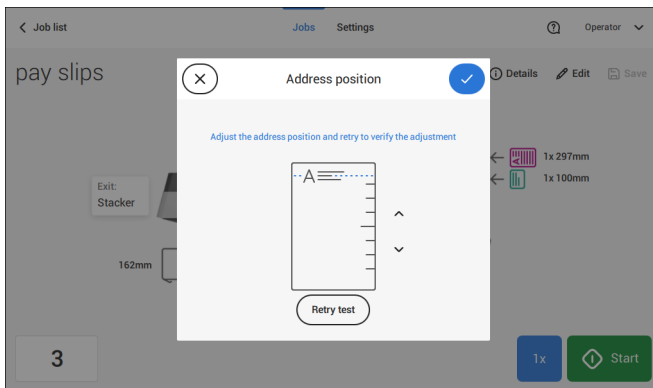

6. Tap the button **[Retry test]** to create another example mail set or tap **[✓]** to confirm the setting.

Adjust the Separation of Special Feeders



Adjust the separation of special feeders as follows:

1. Push knob **A** forward until it clicks.

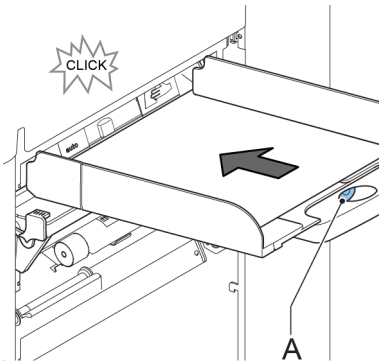

2. Turn knob **A** counter clockwise to open the separation gap.
3. Place a document on the feeder tray and slide it into the system until it can go no further.
4. Turn knob **A** clockwise to get resistance.
5. Move the document to and fro. The separation is adjusted correctly when a slight resistance is felt on the document. Turn knob **A** counter clockwise again if the resistance was set too high.

6. Pull the knob **A** back again when ready.

Process a Mail Set with BRE or Inserts

A mail set with BRE or insert consists of a main document (address carrier), a BRE or an insert and perhaps other enclosures. This set is inserted into an envelope.

1. From the Job list menu, tap **[New job]**.
2. Add the BRE as a (custom) enclosure.
3. Follow the job creation process (see [Create a manual job](#) on page 30).

Process Mail Sets with Daily Mail

To process mail sets with Daily Mail:

1. See [Create a Manual job](#) on page 30 and set the Daily Mail switch to "On".

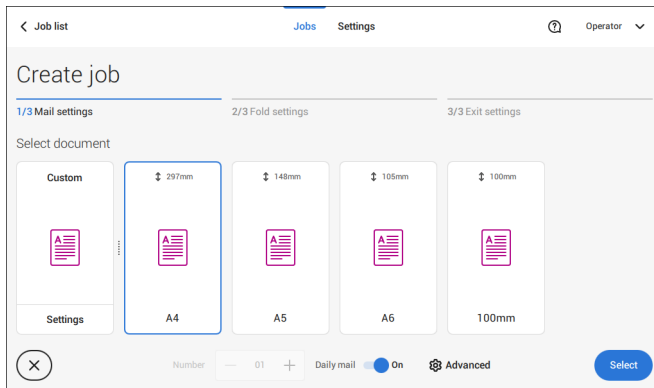

2. Complete the job settings.
3. Tap **[start]** to start the job.

A daily mail switch notification and instruction appears on the screen.

- Turn down the left side guide **A** of the upper tray. Now you can see the Daily Mail handle **B**.

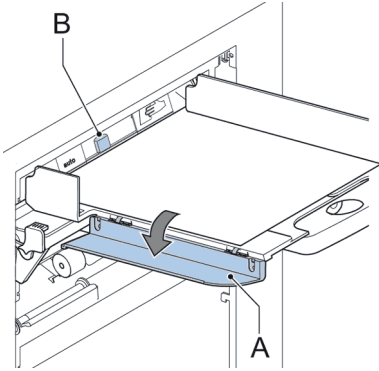

- Move the handle **B** to the right to enable the Daily Mail function.
- Turn side guide **A** upwards.
- Place the document or document set in the feeder tray.
The document or document set will be folded and inserted into the envelope as described in the selected job.
- Place the next document or document set in the feeder tray. The system will keep running to process the inserted document or document set.
- When finished with Daily Mail, tap **[stop]** to stop the job.
- Set the Daily Mail handle **B** to the 'AUTO' position to disable the Daily Mail and enable the automatic document separation.

Create a Job with Custom Envelopes



Makes sure that your custom envelopes fit within the specifications (see [Envelope Specifications](#) on page 143).

- Create a manual job as explained in [Create a Manual job](#) on page 30 and select envelope.

2. Tap on **[Settings]** in Custom (envelope).

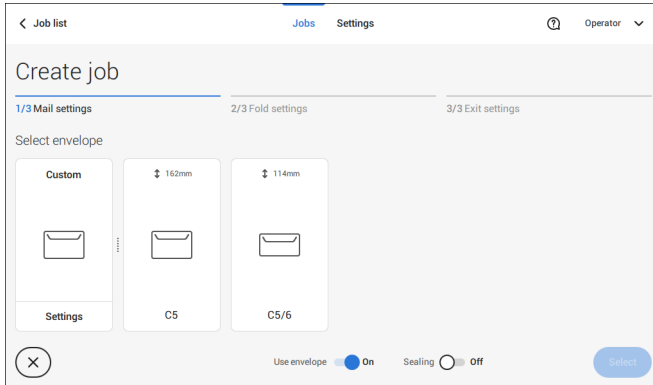

3. Enter the envelope height.

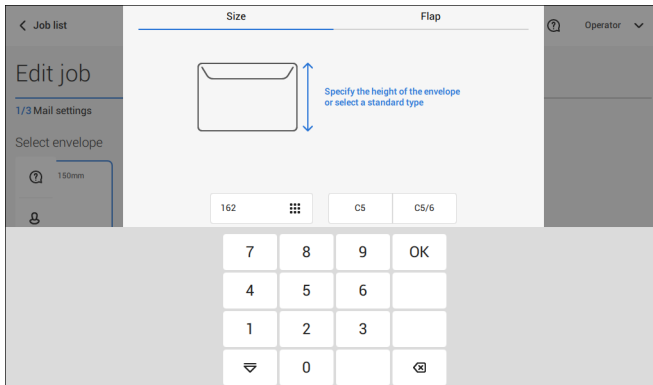

4. Tap the **[Flap]** tab if you use open flap envelopes.
5. Select if you want to feed envelopes with flaps up (On) or with flap down (Off).
6. Tap **[✓]** to save and close the custom envelope settings and tap **[Select]**.
7. Complete the Fold Settings and Exit Settings to complete the job settings. In the job overview tap **[Save]** to save the job.

Follow the instructions as described in '[Create test mail set](#)' on page 42.

Create a Job with Custom Documents



Makes sure that your custom documents fit within the specifications (see [Document Specifications](#) on page 143).

4

1. Create a manual job as explained in [Create a Manual job](#) on page 30 and select a custom document as your main document or enclosure.
2. Tap **[Settings]** in Custom (document) to create a custom document.

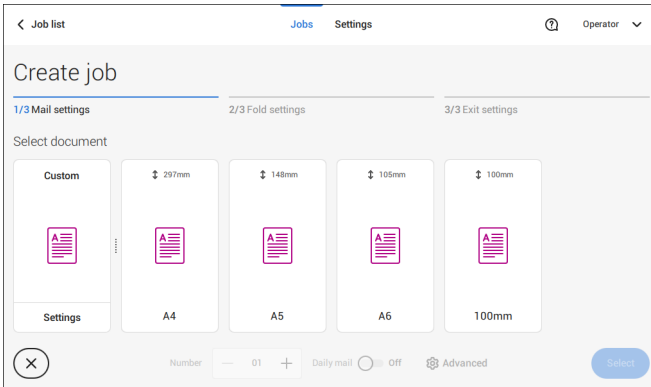

3. Enter the height of the document.



4. Confirm the custom document settings with **[✓]**.
5. Complete the Fold Settings and Exit Settings to complete the job settings. In the job overview tap **[Save]** to save the job.

Follow the instructions as described in '[Create a test mail set](#)' on page 42.

English

Change to Another Feeder Tray



You cannot change the order of the documents in the mail set by changing feeders. If you want to change the order of the mail set, see [Delete or move an enclosure](#) on page 56.

If you want to move the main document or enclosures to another feeder tray:

1. Select a job from the Job list.
2. Tap the document that you want to move to another feeder tray.

All available feeder trays are marked with a blue box.

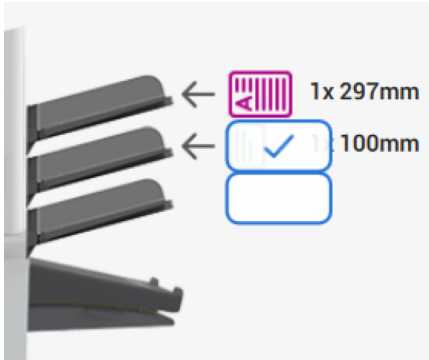

3. Tap the blue box of the feeder tray where you want to move your document to. The new feeder tray is selected for feeding of the document.
 4. Tap **[Save]** to save the feeder tray selection to the job.
-

Link Feeder Trays

Link feeder trays as follows:

1. Select a job from the Job list.
2. Tap the feeder tray that you want to link to another feeder tray.

The link symbol appears.

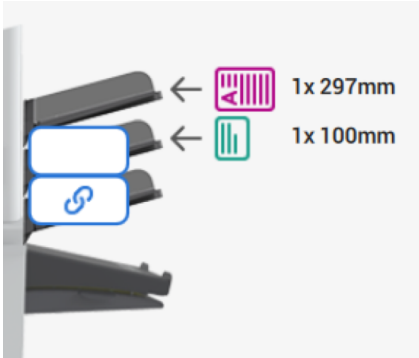

3. Tap the link symbol.

The figure shows an example of linked feeders.

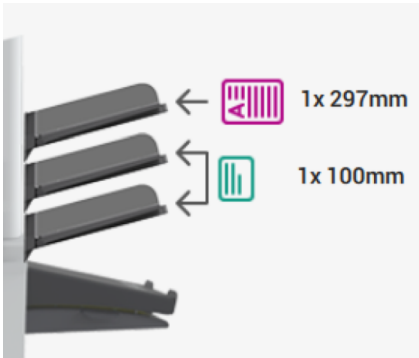

4. Tap **[Save]** to save the link to the job.

When you want to un-link the feeders, tap the feeder trays and tap the un-link symbol.

Edit a Job

To edit an existing job:

1. From the Job list, select a job you want to edit.

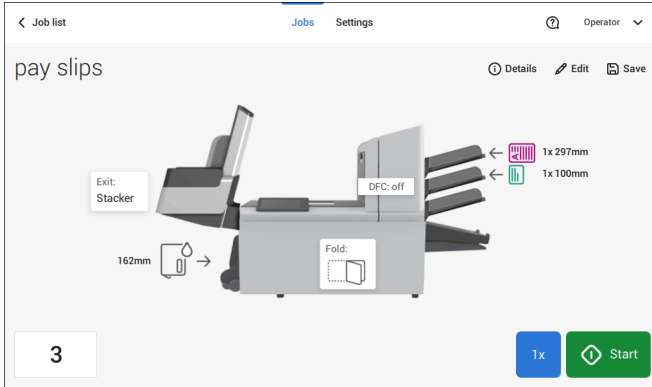

2. Tap **[Edit]**.

When you tap **[Edit]**, you enter the guided job flow that enables you to make the desired changes.

3. Make the changes you want to make. When you completed the job programming, tap **[Save]** to save the changes.
4. Tap **[1x]** to make sure that the Insert Position and Address Position are correct (see [Verifying the Insert Position](#) on page 43 and [Adjusting the Address Position](#) on page 46).

Save a Job

When you have created a new job or edited a job, save the job as follows:

1. After you have completed the job definition, tap **[Save]**.
2. Enter the job name.

3. If necessary, add a description to the job. The description is visible in the job list.

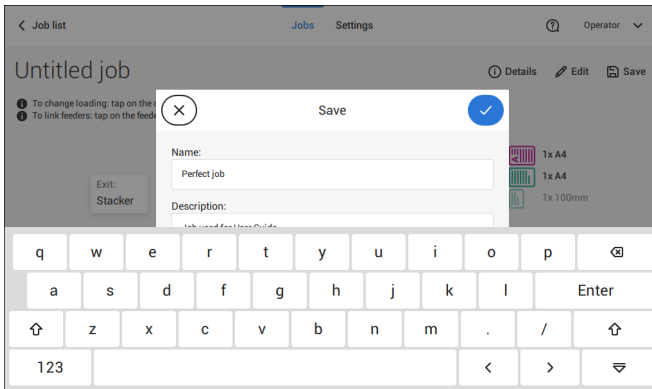

4. Tap [✓] to save the job.

The job is added to the job list.

Delete or Move an Enclosure

If you want to delete an enclosure in your job or change the order of the enclosures, proceed as follows:

1. From the Job list, select a job you want to edit.
2. Tap [Edit].
3. Tap and hold the enclosure you want to move or delete.

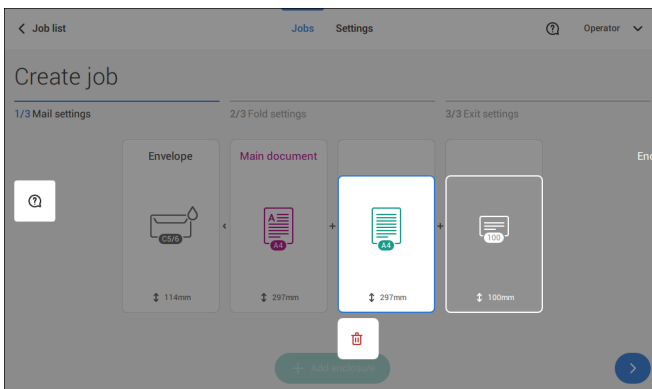

Now drag the enclosure to an other position. Or tap the waste bin to delete the enclosure from your mail set.

4. Tap the arrow buttons [>] to pass the other job definition steps and close the job editor.
5. Tap **[Save]** to save the changes.
6. Tap **[1x]** to make sure that the Insert Position and Address Position are correct (see [Verifying the Insert Position](#) on page 43 and [Adjusting the Address Position](#) on page 46).

Copy a Job

To copy existing job settings to a new job:

1. Tap and hold the job in the Job list. A pop-up screen will appear.

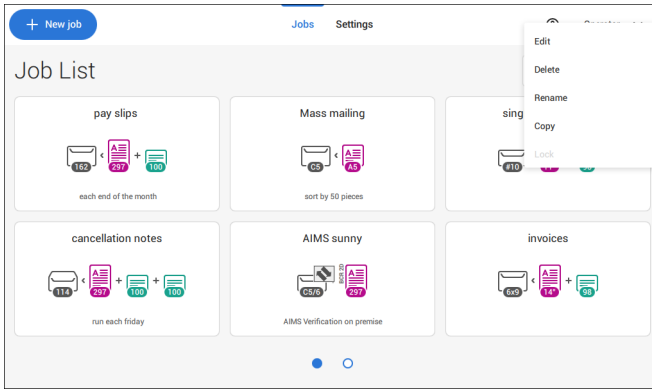

2. Tap **[Copy]**.
3. Enter the name of the new job and tap **[✓]**.

Delete a Job

To delete an existing job:

1. Tap and hold the job in the Job list.

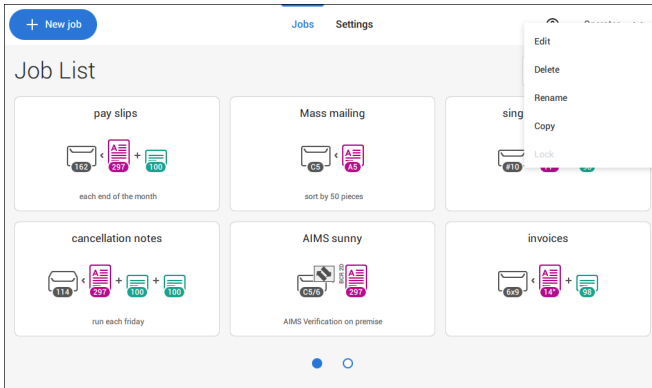

2. Tap **[Delete]**.
3. Tap **[✓]** to confirm.

Rename a Job

To rename a job:

1. Tap and hold the job in the Job list.

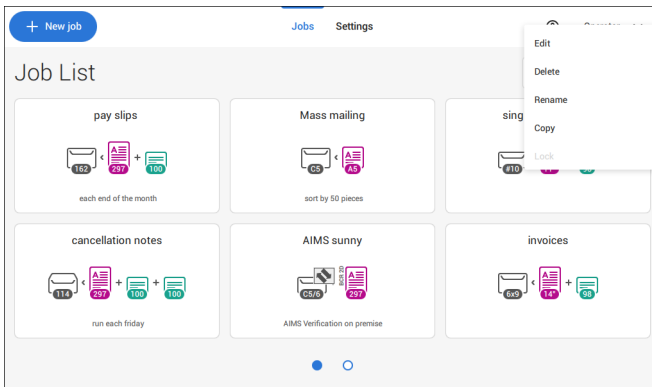

2. Tap **[Rename]**.
3. Enter the name of the new job and tap **[✓]**.

Lock a Job

To lock an existing job:

1. Log on as supervisor.
2. Tap and hold the job in the Job list.

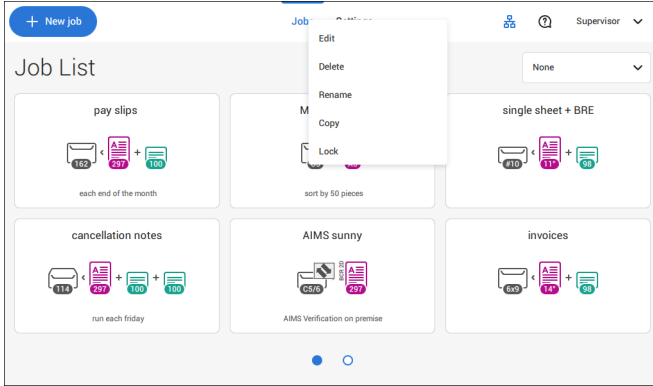





3. Tap [**Lock**].
4. Tap [**✓**] to confirm.

The job shows a lock in the job list. If the supervisor is logged on, the lock is open. If the operator is logged on, the lock is closed. The operator cannot edit, delete or rename the job, when the job is locked.

5 Loading the System

Document Orientation

The touch screen shows how to load documents and envelopes into the feeders. The table shows the meaning of the symbols:

	Address carrier face up and leading (top address)
	Address carrier face down and trailing (top address)
	Enclosure face up
	Enclosure face down

Document Feed Trays

Install the Document Feed Trays



Place the document feeder trays in position:

1. Hold the document feeder tray slightly inclined as shown in the figure.

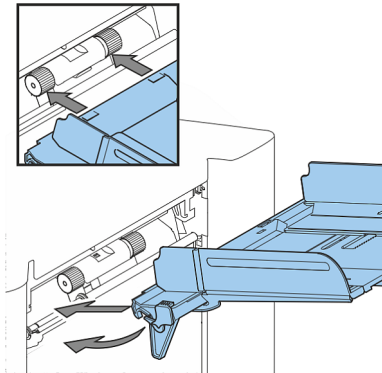

2. Place the front end of the document feeder tray underneath the two black rollers.

3. Move the document feeder tray upwards (lifting the black rollers), until it is possible to 'hook' the feeder into place.

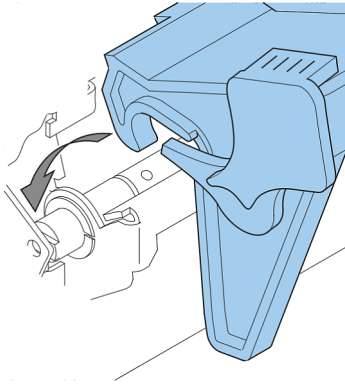

4. Move the document feeder tray towards the machine and move the hooks over the mounting points (on both sides).
5. Let the document feeder tray rest on the machine.

Adjust the Side Guides



To adjust the side guides it is best to remove the document feeder tray from the feeder as follows:

1. Push handle **A** downwards.

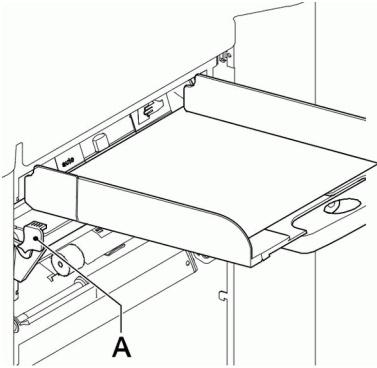

2. Lift the document feeder tray upwards to unhook it and then pull it out from the feeder.
3. Loosen the knob **B** half a turn.

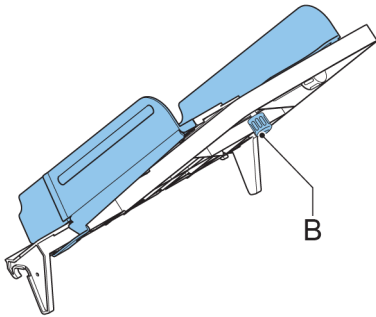

4. Grab the side guides in the middle and push them apart as far as possible.
5. Put a small stack of documents between the side guides.
6. Grab the side guides in the middle and push them towards the documents.
The space between the side guides and the documents should be such that the documents have just enough play to move freely.
7. Re-tighten knob **B**.
8. Remove the stack of documents.
9. Replace the document feeder tray (see [Installing the Document Feeder Trays](#) on page 61).

Load Documents



Fill the document feeder tray as follows:

1. Open the left-hand side guide **A** by turning it downwards.
The feed rollers will automatically be lifted.

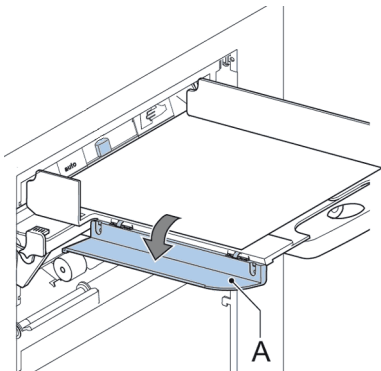

2. Place a stack of documents between the side guides.
 3. Turn the left side guide upwards again.
-

Document Separation

The term 'Document separation' refers to the adjustment required for separating the upper document from the rest of the documents in the stack. This prevents pulling too many documents from the stack at the same time.

The document separation for the automatic feeders is set automatically; there are no manual adjustments needed.

Feeders can be special feeders. The document separation for special feeders must be adjusted manually. While special feeder trays fit in all positions, adjusting the separation is only possible when they are fitted on position 1 and 2.

To adjust the separation of special feeders follow the instructions as described in [Adjust the Separation of Special Feeders](#) on page 48.

Production Feeder

Adjust the Production Feeder Side Guides



Adjust the side guides:

1. Take a stack of documents/BREs and place them in the feeder tray. BREs with flap down and leading (top side pointing to system).

2. Adjust the side guides by turning the thumb wheel **A** such that the documents/BREs just fit and can move without resistance. Too much play causes skewing.

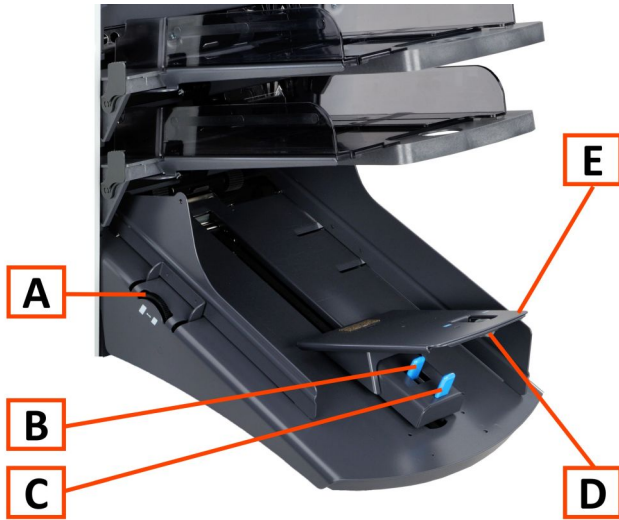

Item	Description
A	Thumbwheel for adjusting side guides
B	Handle for unlocking the feeding plate E (use in combination with C)
C	Handle for unlocking the feeding plate E (use in combination with B)
D	(Manual) Separation adjustment knob
E	Feeding plate

Adjust the Production Feeder Document Separation

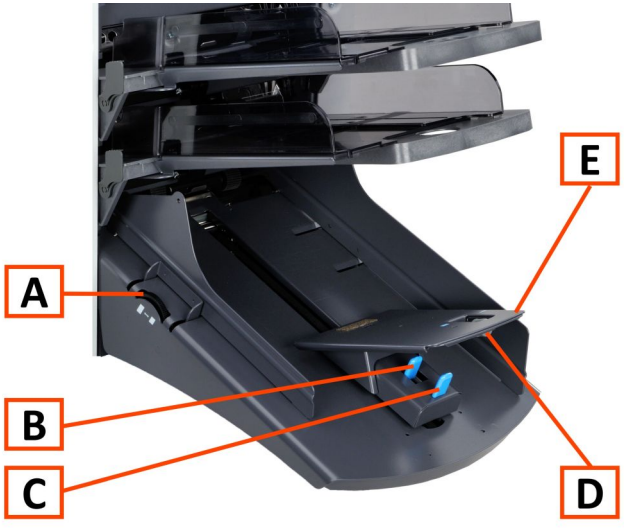

Item	Description
A	Thumbwheel for adjusting side guides
B	Handle for unlocking the feeding plate E (use in combination with C)
C	Handle for unlocking the feeding plate E (use in combination with B)
D	(Manual) Separation adjustment knob
E	Feeding plate

When the Production Feeder is used at an automatic separation feeder, the separation is set automatically.

The Production Feeder can also be used on a feeder position with a manually adjusted separation. To adjust, proceed as follows:

1. Remove the document feeder trays 2 and 3.



The lowest feeder is feeder 1.

2. Squeeze the two blue handles **B** and **C** and shift the feeding plate **E** as far as possible to the front.
3. Push knob **D** forward until it clicks.
4. Place a document/BRE on the feeder tray and slide it in the system till the leading edge is not visible anymore. Turn knob **D** counterclockwise if the separation is set to narrow.
5. Push the document/BRE between the rollers.
6. Turn knob **D** clockwise to get more resistance and counterclockwise if the separation is set to narrow.
The separation is adjusted correctly when a slight resistance is felt on the document/BRE.
7. Pull knob **D** back when ready.
8. Replace the document feeder trays 2 and 3.

Load Documents (Production Feeder)





When loading the Production Feeder, make sure that the document/BREs are positioned parallel in relation to the feeding plate assembly to ensure correct feeding.

The feeding plate assembly will be shifted up automatically (when the system starts processing) until documents/BREs are underneath the rubber paper pullers.

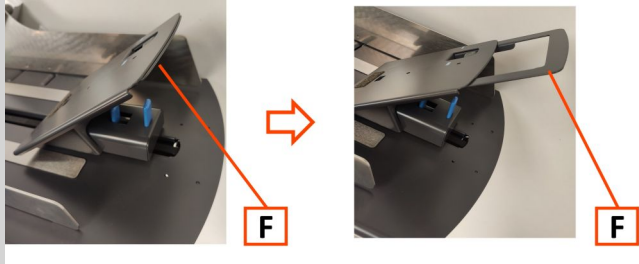

In case of long documents, use the feeding plate extension F to support the documents.

Instead also an optional A4 or 11" support plate can be used to support long documents. Ask your local distributor for more information about these optional support plates.

To load documents:

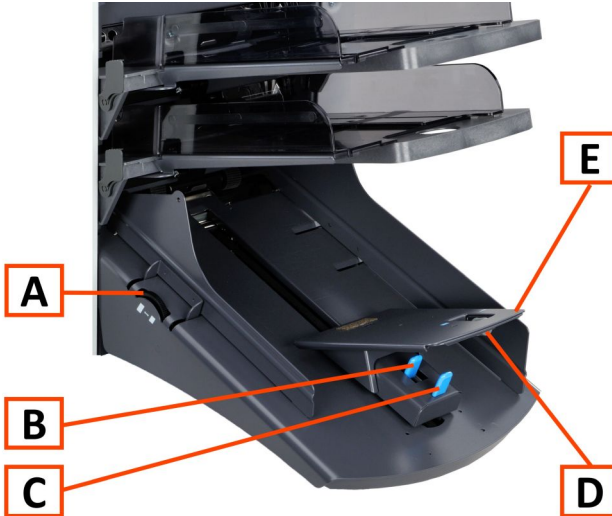

Item	Description
A	Thumbwheel for adjusting side guides

B	Handle for unlocking the feeding plate E (use in combination with C)
C	Handle for unlocking the feeding plate E (use in combination with B)
D	(Manual) Separation adjustment knob
E	Feeding plate

1. Squeeze the two blue handles **B** and **C**.
2. Shift the feeding plate assembly **E** to the rear position.
3. Loosen the stack of documents and place them in the feeder tray. BREs with flap down and leading (top side pointing to system).

High Capacity Document Feeder

Adjust the Side Guides



To adjust the side guides B:

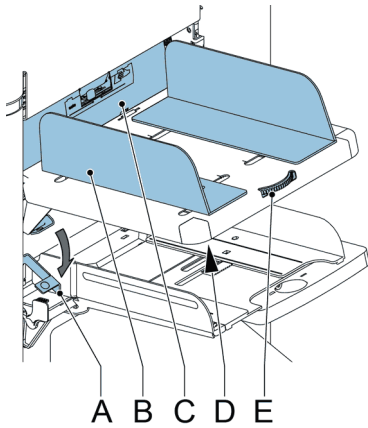

1. Loosen knob **D**, which is located underneath the feeder tray, half a turn.
2. Put a small stack of documents between the side guides.
3. Rotate wheel **E**.
The space between the side guides and the documents should be such that the documents have just enough play to move freely.
4. Re-tighten knob **D**.

Load Documents (HCDF)



To load the document feeder tray:

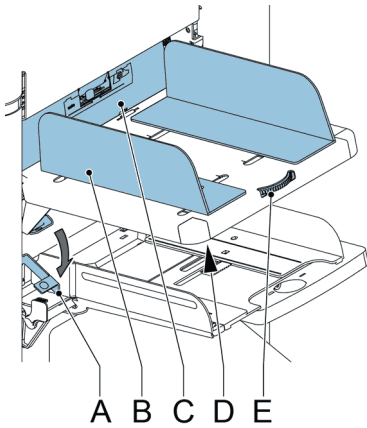

1. Pull down lever **A**.
The feeder rollers **C** move up to filling level.
2. Place a stack of documents between the side guides (max. 725 sheets, 80 g/m²).
See [Document Orientation](#) on page 60 how to place the documents in the feeder tray.
3. Release lever **A**.

Loading Envelopes



LOADING ENVELOPES



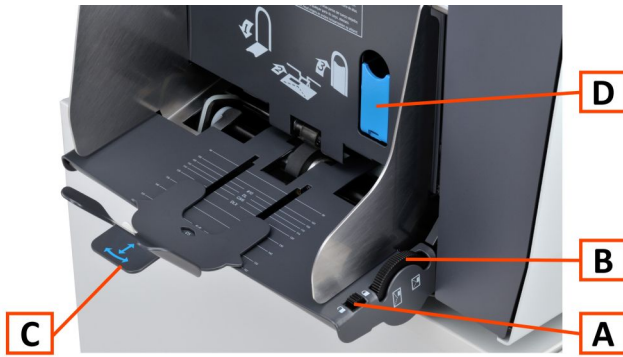

Item	Description
A	Side guide adjustment lock (to prevent unintentional misadjustments).
B	Thumbwheel for side guide adjustment.
C	Envelope support to ensure correct feed angle.
D	Lever to set/reset envelope separation.

Loading envelopes correctly will help to prevent jams and misfeeds. Make sure the envelope separation and side guides are correctly set. Proceed as follows:

1. Make sure the locking knob **A** is in the unlock position.
2. Rotate thumb wheel **B** to move the side guides apart.
3. Shift the envelope support **C** out.
4. Loosen a stack of envelopes and place the stack between the side guides.
5. Move the side guides towards the envelopes.

The space between the side guides and the envelopes should be such that the envelopes have just enough play to move freely.



If the distance between the side guides is too large, the envelopes will twist sideways, when transported into the machine.

6. Lock the side guides using the locking knob **A**.
7. Remove the stack of envelopes.

- Shift the envelope support **C** in the correct position, according to the printed scale and matching the envelope size (height).

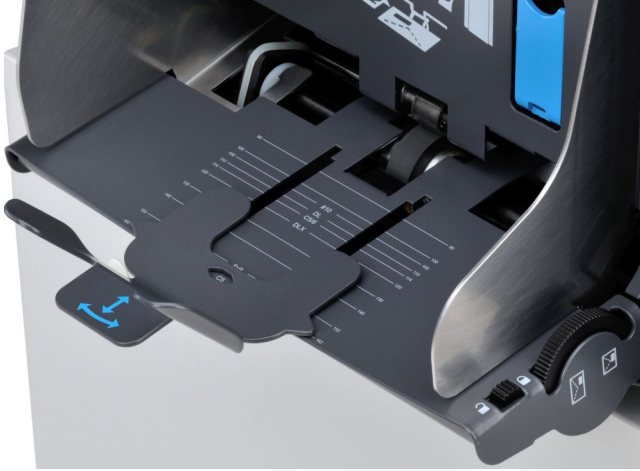

- Pull down lever **D** and insert one envelope up to the stoppers. The position of the envelope is flap down and trailing (bottom side of the envelope pointing to the system).



- Return lever **D**.

By returning the lever the separation is set to the envelope thickness between the rollers.



When the envelope separation lever **B** is pulled down, the envelope separation is cleared. If lever **B** is accidentally pulled down the separation must be reset with one envelope.

11. Loosen a stack of envelopes and place the stack on top of the bottom envelope between the side guides.



If envelopes are warped the envelope support can be set at an angle to better guide the flow of envelopes.

Fill the Sealing Liquid Reservoir



1. Open the front cover **B**.
2. Fill the reservoir **A** to the "Max" lip with sealing liquid.
3. Close the front cover **B**.

Before starting the job, wait approximately 5 minutes for the brushes to moisten or use moistened brushes. For instructions on the installation of brushes, see the User Guide, section [Clean and replace brushes](#) on page 125.

5

English

6 Settings menu

Changing screen display

In all settings menus (operator as well as supervisor) information shown might not be visible at a glance. You will notice that the following icon is available:

 ; this icon will enlarge the view of your screen.

For example in the Display settings the 'normal' view will show:

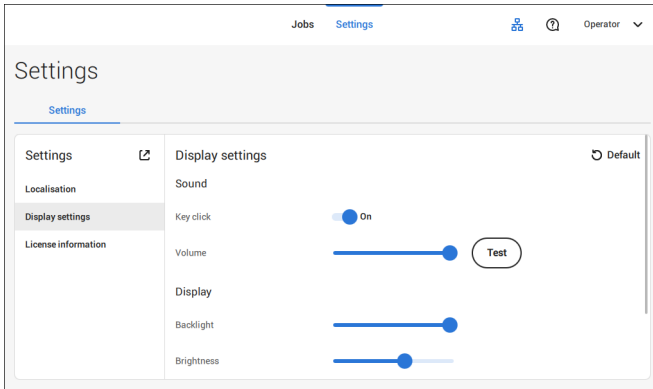

Tapping the  icon will enlarge the view.

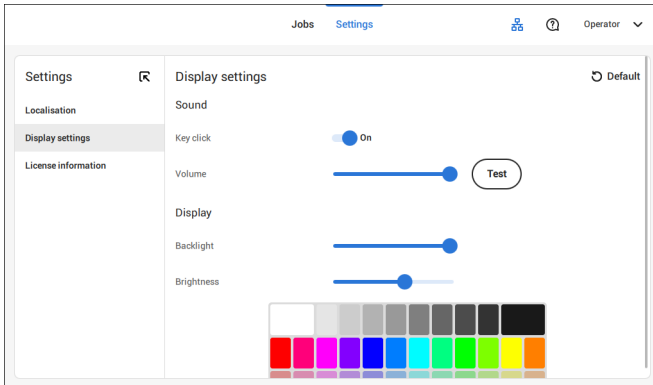

In the enlarged view you will find the  icon. Tapping this icon will reduce the view of your screen again (back to 'normal' view).



Double tapping anywhere on the touch screen, in one of the settings menus, will also result in enlarging (or reducing) the view.

Open the Operator Settings Menu

In the settings menu for the operator it is possible to edit the display settings, to set the localisation and to view license information.

If you want to view or edit any of the Operator Settings:

1. Tap **[Settings]** at the top of the touch screen.



2. Tap **[Localisation]** if you want to change the document standard or the language.

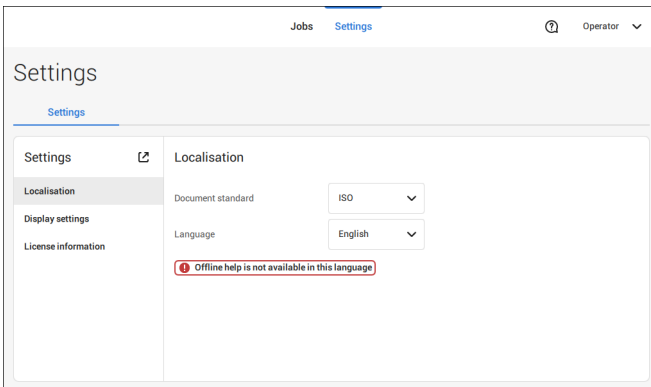

3. Tap **[Display settings]** if you want to:

- set the 'Key' click to on/off
- set the Volume
- set the Backlight
- set the Brightness

To set the backlight and brightness, a test pattern is available as a reference.

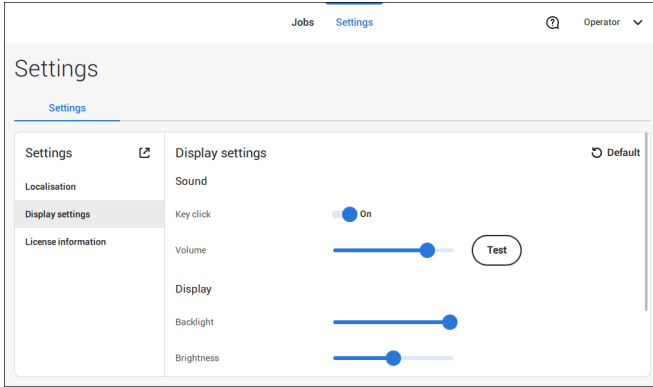

4. Tap **[License information]** if you want more information on Open source licenses.

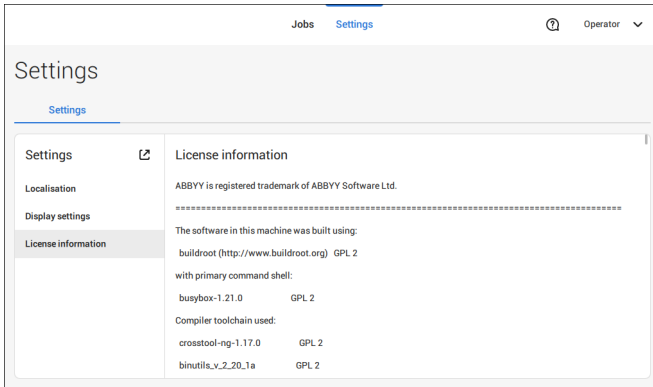

For more information on Open source licenses, see [License information](#) on page 92 (requires Supervisor login).

The Supervisor Settings Menu

Supervisor Settings are all settings that can be found under the Settings Menu when logged in as supervisor (pin code 2546). The following flowchart shows which subjects are available via the Supervisor settings menu. It is possible to view or edit any of the Supervisor Settings.

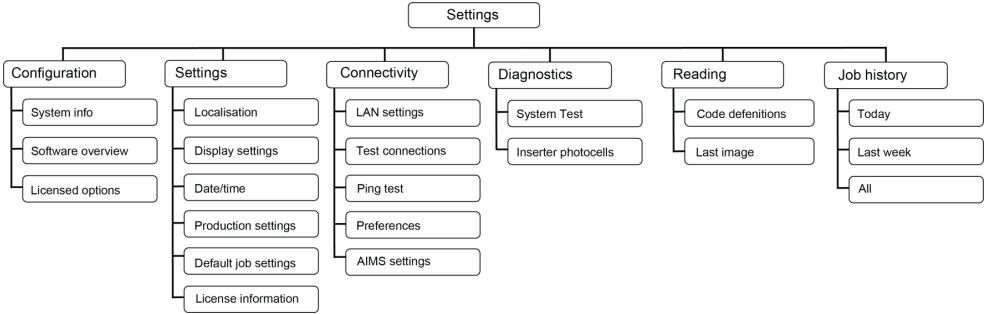

Supervisor Settings Menu

Open the Supervisor Settings Menu

If you want to view or edit any of the Supervisor settings proceed as follows:

1. Login as Supervisor with pin code **2546**.

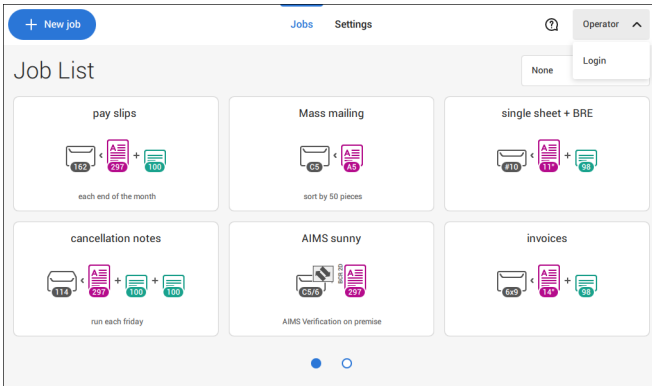

2. Tab **[Settings]** at the top of the touch screen.

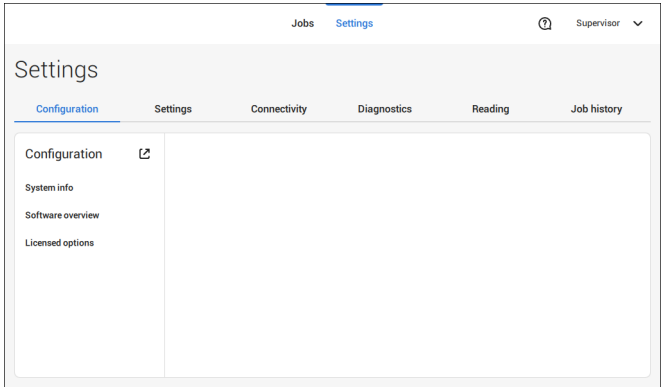

Configuration

Configuration

The Configuration menu contains information and settings about the configuration of the system.

System Info

The System info part of the Configuration menu shows the following information:

- Serial number of the system
- Flex certificate - this option is used for reading
- Counter since last visit - the counter value since the last service visit
- Last error (description) - The last error and error description generated by the system
- Board (PCB) revision

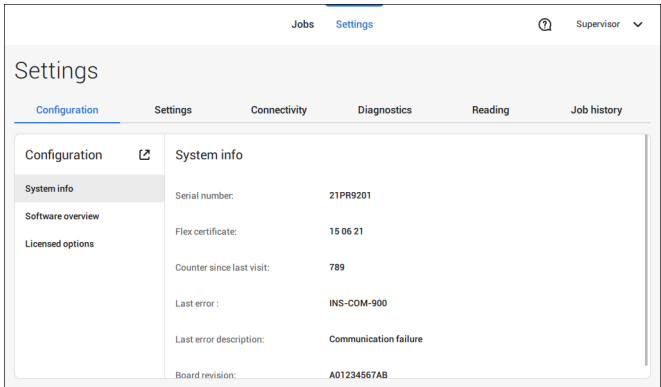

Software Overview

The Software overview part of the Configuration menu shows the versions of the software that is present in the total system.

Jobs Settings Supervisor

Settings

Configuration Settings Connectivity Diagnostics Reading Job history

Configuration

System info

Software overview

Licensed options

Software overview

Package Id: 1

Inserter

Name	Part number	Revision	Build number
Inserter	A0137659	A	91786
Reading Generation 2	A0129014	H	92072
System Control	A0119111	G	92039
DS Control MMI	A0146074	A	91775



English

Licensed Options

The Licensed options part of the Configuration menu shows the following information:

- Chip ID
- Serial number
- Installed options

The installed options are enabled with license codes. These license codes, together with the identification number of the machine enable the relevant options. The enabled and available software options are displayed in this screen. Contact your dealer for information about these license codes.

The system supports the following licensed options:

- Online help
- Advanced/Basic reading
- OMR 1 track
- BCR 1D/2D
- Flex reading
- Production Feeder 356mm

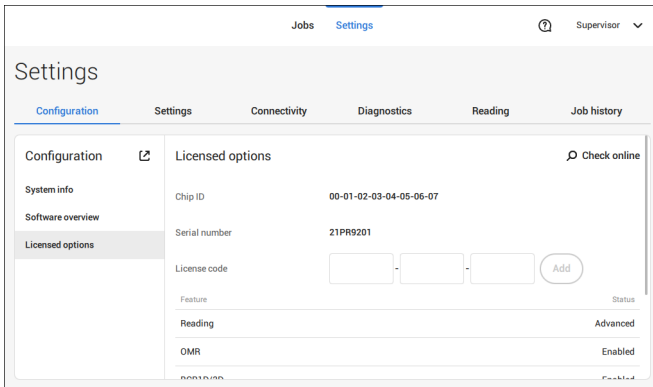

Online Feature (Licenses) Management

At powerup the system does an online check, provided that it is connected to a network, to determine if new features/licenses have become available.



New licenses will be installed automatically.

Add a Licensed Option manually

To add a licensed option manually:

1. In the Configuration, Licensed options screen, enter the license code.

The screenshot shows the 'Settings' application interface. At the top, there are tabs for 'Jobs' and 'Settings', and a 'Supervisor' dropdown menu. Below the tabs, there are sub-tabs for 'Configuration', 'Settings', 'Connectivity', 'Diagnostics', 'Reading', and 'Job history'. The 'Configuration' sub-tab is selected, and the 'Licensed options' screen is displayed. The screen shows a list of fields: 'Chip ID' (00-01-02-03-04-05-06-07), 'Serial number' (21PR9201), and 'License code' (00000-00000-00000). An 'Add' button is highlighted with a red circle. Below the license code, there are rows for 'Feature', 'Reading', and 'OMR', each with a 'Status' column. The 'Status' for 'Reading' is 'Advanced' and for 'OMR' is 'Enabled'.

2. Tap **[Add]**.

The system verifies the license key.

If the license key has been verified successfully, the option is added to the system and can be used.

Settings

Settings

The Settings menu contains specific configuration settings for the system.

Localisation

Tap **[Localisation]** if you want to change the document standard or the language.

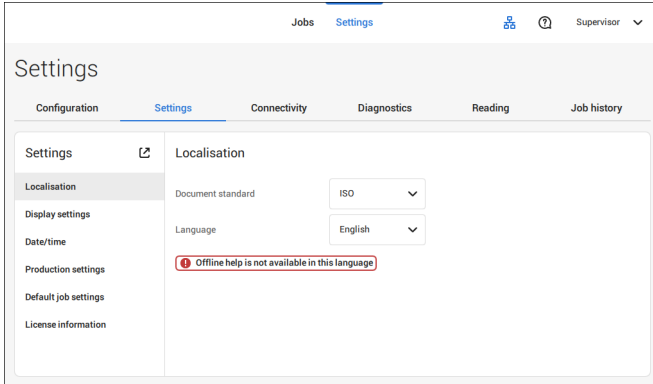

When you need a keyboard to enter e.g. a job name, you get a special keyboard in case of Russian, Czech and Katakana. But the keyboard has always a button to switch back to the "English" keyboard.

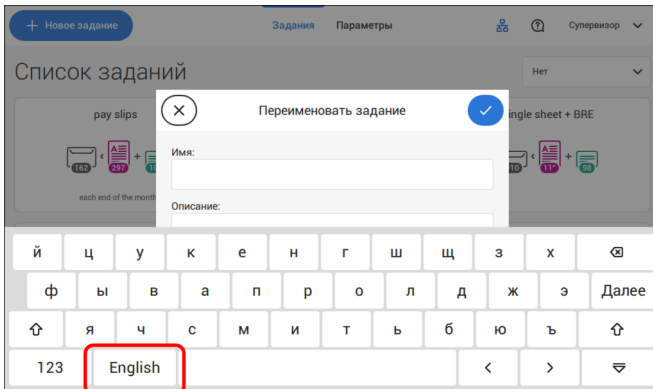

Display Settings

Refer to the the [Operator Settings Menu](#) on page 78 for the operator.

Date-time

Tap [**Date/time**] to set the:

- Date
- Time
- Date format; you can choose between three format to show the date: dd-mm-yyyy, mm-dd-yyyy or yyyy-mm-dd
- Time format; you can choose between a '12 hours' notation or a '24 hours' notation
- Time zone

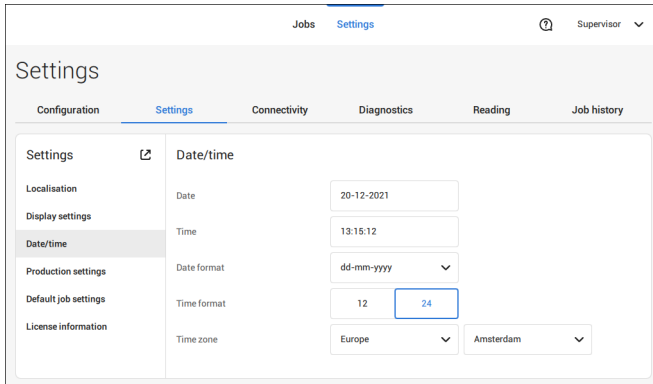

The screenshot shows the 'Settings' application interface. At the top, there are tabs for 'Jobs' and 'Settings', with 'Settings' selected. A 'Supervisor' dropdown menu is visible in the top right corner. Below the tabs, there are sub-tabs for 'Configuration', 'Settings', 'Connectivity', 'Diagnostics', 'Reading', and 'Job history', with 'Settings' selected. The main content area is titled 'Settings' and contains a list of settings categories: 'Localisation', 'Display settings', 'Date/time', 'Production settings', 'Default job settings', and 'License information'. The 'Date/time' category is selected and expanded, showing the following configuration options:

Setting	Value
Date	20-12-2021
Time	13:16:12
Date format	dd-mm-yyyy
Time format	12 / 24
Time zone	Europe / Amsterdam

Production Settings

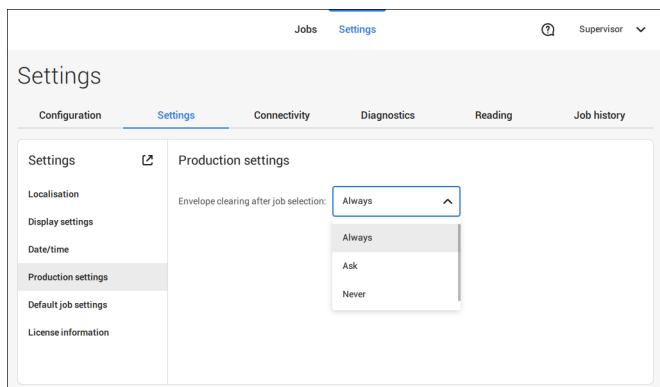

The Production Settings part of the Settings Menu covers settings regarding the clearing of the envelope track when selecting a (another) job from the job list or when starting a new automatic job.

The screen shows three options:

- Always
- Ask
- Never

It makes a difference if you switch from a job to another (existing) job from the job list or if you start creating a new automatic job.

Switch to an existing job

If the user selects "**Always**"; after tapping 1x or Start: the system shows a popup asking to clear the envelopes or continue without clearing. The following two options are possible:

1. The user chooses to clear the envelope:
 - a. The system start transporting envelopes present in the system to the exit. For safety a maximum number of envelopes is processed. This maximum is set to 3.
 - b. If the system still detects envelopes after the maximum is reached, the system shows a warning (INS-EH1-002) that there are still envelopes in the hopper that should be removed.
 - c. When the user cancels the dialog with the 'X', the system returns to the Idle screen without clearing or producing.
 - d. After clearing, the system returns to the idle screen.
2. The user chooses to continue without clearing:
 - a. The system starts producing with the envelopes loaded in the system.

If the user selects "**Ask**"; after tapping 1x or Start: the system shows a popup asking to clear the envelopes or continue without clearing. The following two options are possible:

1. The user chooses to clear the envelope:
 - a. The system start transporting envelopes present in the system to the exit. For safety a maximum number of envelopes is processed. This maximum is set to 3.
 - b. When the user cancels the dialog with the 'X', the system returns to the Idle screen without clearing or producing.
 - c. After clearing, the system returns to the idle screen.
2. The user chooses to continue without clearing:
 - a. The system starts producing with the envelopes loaded in the system.

If the user selects "**Never**" and envelope settings have not been changed; after tapping 1x or Start: the system starts producing with the envelopes loaded in the system.

If the user selects "**Never**" and envelope settings have been changed; after tapping 1x or Start: the system shows a popup asking to clear the envelopes or continue without clearing. The following two options are possible:

1. The user chooses to clear the envelope:
 - a. The system starts transporting envelopes present in the system to the exit. For safety a maximum number of envelopes is processed. This maximum is set to 3.
 - b. When the user cancels the dialog with the 'X', the system returns to the Idle screen without clearing or producing.
 - c. After clearing, the system returns to the idle screen.
2. The user chooses to continue without clearing:
 - a. The system starts producing with the envelopes loaded.

Create a new automatic job

If the user selects "**Always**"; after tapping 1x the system shows a popup asking to clear the envelopes or continue without clearing. The following two options are possible:

1. The user chooses to clear the envelope:
 - a. The system starts transporting envelopes present in the system to the exit. For safety a maximum number of envelopes is processed. This maximum is set to 3.
 - b. If the system still detects envelopes after the maximum is reached, the system shows a warning (INS-EH1-002) that there are still envelopes in the hopper that should be removed.
 - c. When the user cancels the dialog with the 'X', the system returns to the Idle screen without clearing or producing.
 - d. After clearing, the system returns to the idle screen.
2. The user chooses to continue without clearing:
 - a. The system starts producing with the envelopes loaded.

If the user selects "**Ask**" or "**Never**"; after tapping 1x: the system shows a popup asking to clear the envelopes or continue without clearing. The following two options are possible:

1. The user chooses to clear the envelope:
 - a. The system starts transporting envelopes present in the system to the exit. For safety a maximum number of envelopes is processed. This maximum is set to 3.
 - b. When the user cancels the dialog with the 'X', the system returns to the Idle screen without clearing or producing.
 - c. After clearing, the system returns to the idle screen.
2. The user chooses to continue without clearing: the system starts producing with the envelopes loaded.

Job Settings



Job settings normally will be changed by a service engineer only. Therefore first consult the service organization before you change any settings. Changes to the job settings can result in malfunctioning of jobs.



You can also define the job settings per job. Select a job from the Job list, tap Edit, navigate to the Exit settings, and tap Advanced.

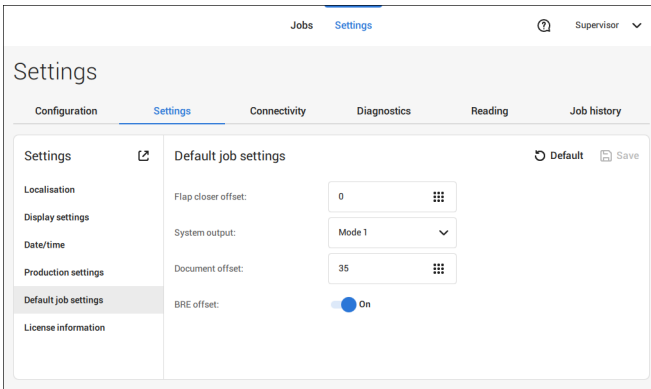

The Job settings part of the Settings menu covers settings that improve the processing of jobs:

- **Flap closer offset:** To delay or advance the moment of flap closing, you can enter a number between -20 and 20 to fine tune the closing of the envelope.
- **System output:** mode 1 mode 2
Mode 1 focuses on the versatility of paper parameters (paper thickness; document length), i.e. correct operation under even extreme paper conditions. Mode 2 is the default mode, and focuses on high speed. Use Mode 1 with a paper thickness of 65 g/m² or less, a document length of 12 inch (305 mm) or higher, and for situations where Mode 2 is not functioning properly. In all other cases use Mode 2.
- **BRE with window:** if the BRE has a window, set this setting to yes. Only available with Mode 2.
- **Document offset (A in the figure):** the extend to which documents are not overlapping in the vertical transport. In the vertical transport of documents fed by the various feeders, the documents are partially overlapping each other. This to make sure that the documents are properly aligned in the collator area. The default value is 50 mm (2.0 inch). The document offset can be varied between 20 mm (0.8 inch) and 250 mm (9.8 inch).

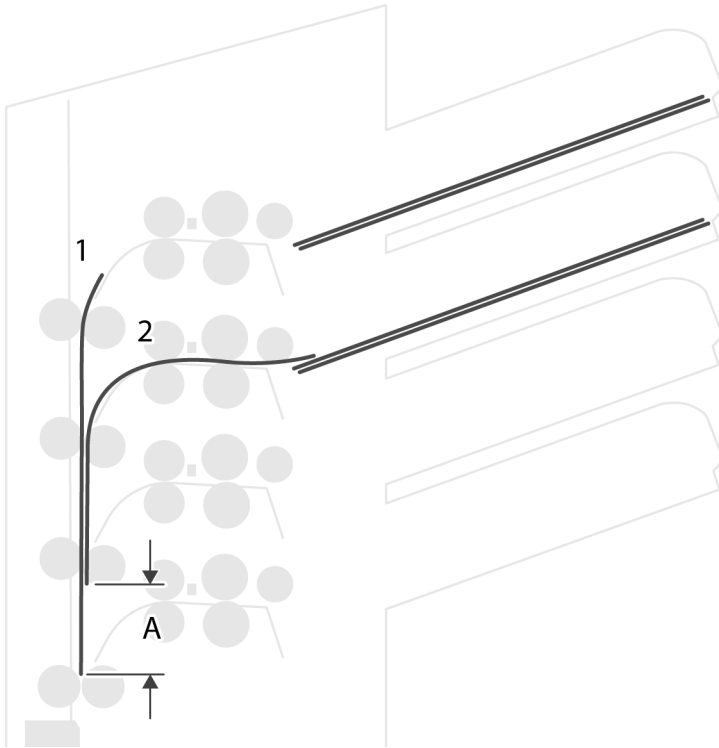

- **BRE offset:** in the case of offset is "yes", the last document that was added to the set is shifted from the rest of the set (offsetting, see below).
- **Collator stop optimisation:** if set to "off", the system does not show a message, when a collator stop change can improve the system output.

Explanation of BRE offset: if a BRE is longer than the set fold but shorter than the envelope height, this BRE can get folded (A in the figure). Under certain conditions (see below) you can prevent the BRE from being folded. In the case of offset "yes", the BRE is held back during a certain distance (B in the figure). This means that the trailing edge of the BRE leaves the collator last. The document is not folded. During the insertion into the envelope the documents of the set are aligned.

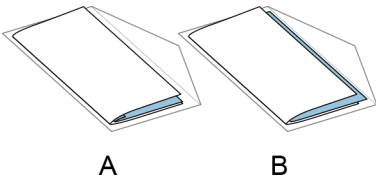

A

B

The conditions are:

- No multi-feed is used for the BREs.
- The document directly under the BRE must have a height of at least 60 mm (2.4 inch) more than the BRE.
- The height of the BRE is more than the set fold length.
- The folding mode is either V-fold or C-fold (no Z-fold).
- The BRE must be shorter than the envelope height.

The whole BRE offset is based on friction between documents within a set. Therefore it is necessary to make use of these conditions to reduce the risk of bad transporting, folding and inserting.



It is possible to use the BRE offset for a BRE and an enclosure (card) in one set. The extra condition is that this enclosure is equal to or smaller than the set address fold and should be placed direct underneath the BRE in the set.

License information

License information shows information on the open source software that is used in the system.

The screenshot shows a web interface for 'Settings'. At the top, there are tabs for 'Jobs' and 'Settings', and a 'Supervisor' dropdown menu. The 'Settings' page has sub-tabs: 'Configuration', 'Settings', 'Connectivity', 'Diagnostics', 'Reading', and 'Job history'. The 'Settings' sub-tab is active, and the 'License information' section is selected in the left sidebar. The main content area displays the following text:

```
ABBY is registered trademark of ABBYY Software Ltd.
*****
The software in this machine was built using:
buildroot (http://www.buildroot.org) GPL 2
with primary command shell:
busybox-1.21.0 GPL 2
Compiler toolchain used:
crosstool-ng-1.17.0 GPL 2
binutils_v_2.20.1a GPL 2
```

Connectivity

See [Connect the system to the internet](#) on page 100.

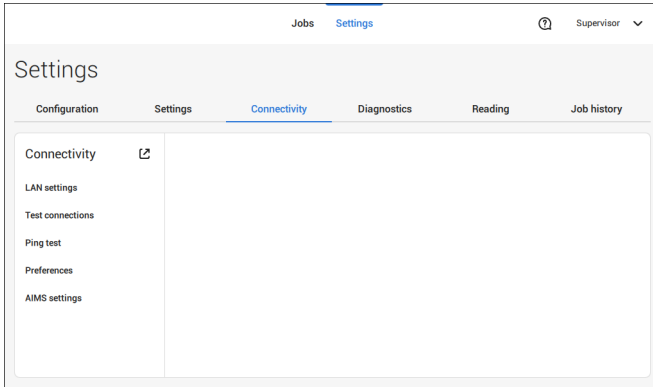

Diagnostics

Diagnostics

The diagnostics menu contains the basic diagnostics functions available for a supervisor.

System Test

Use the **[System test]** to check if all motors, clutches and sensors are correctly connected. The test briefly activates the actuators and clutches and measures the current.

To run a system test:

1. In the Settings menu, tap the **[Diagnostics]** tab.

2. Tap [System test].

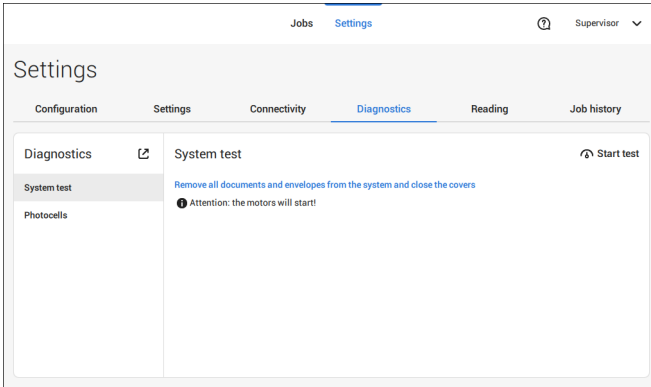

3. Remove all documents and envelopes and close all covers before starting the diagnose.
4. Tap [Start test].
5. When the test is finished, the Status report is shown, showing the status of all tested items. If the tests fail, contact your service organization.

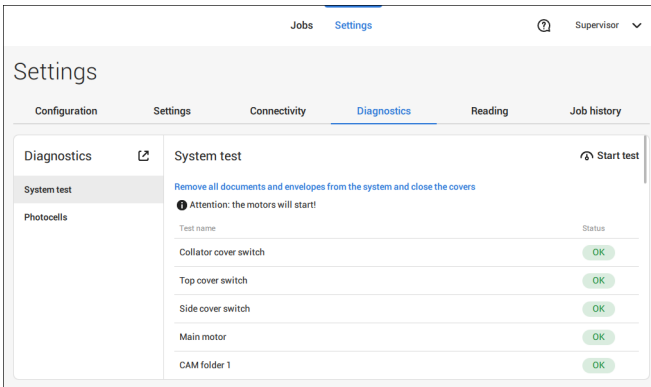

Photocells

When too much paper dust is built up at the sensors a warning message will be displayed. To check the conditions of the photocells or to calibrate them follow the instructions as described in [Calibrate photocells](#) on page 127.

Reading

Reading

In the reading menu it is possible to view and to add new code definitions. It is also possible to view the last image that has been read by the system.

Because reading is optional, this menu is only available when there is at least one reading license present.

For more information on the reading option, see [Reading](#) on page 108.

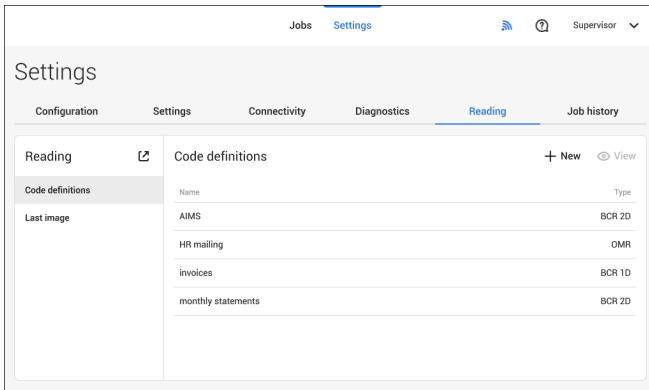

Viewing and adding code definitions

When logged on as Supervisor it is only possible to view or to add code definitions. Editing, copying, renaming or deleting a code definition can only be performed by a service engineer. Contact your local distributor if one of these actions have to be executed.

Viewing available code definitions.

1. From the (main) Reading menu window tap **[Code defenitions]**.

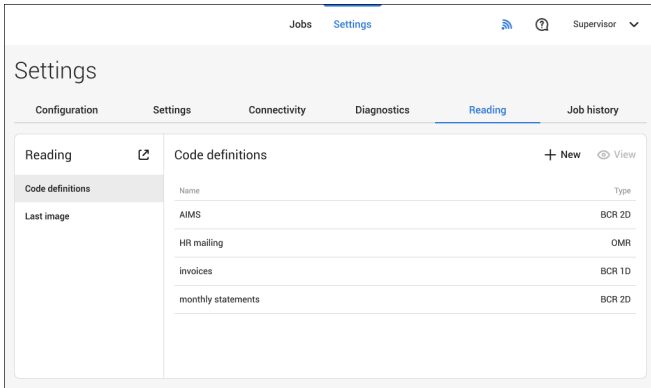

2. Select a code definition. The **[View]** button will become active.

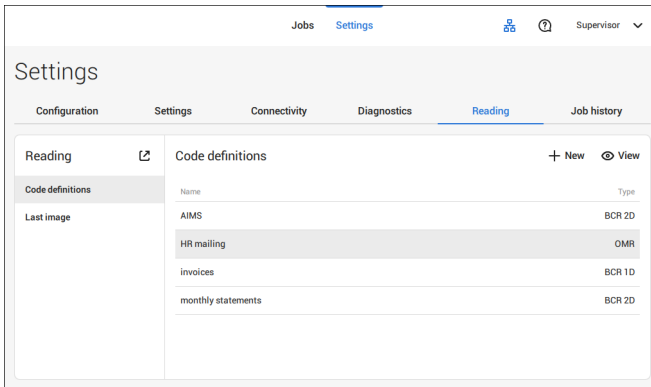

3. Tap **[View]**. Information about the code definition will be displayed.

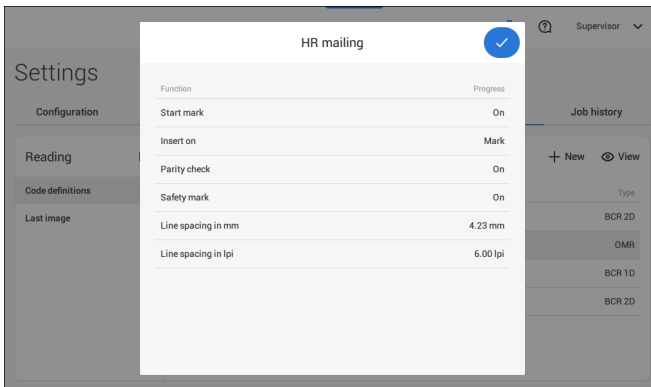

Adding a new code definition

1. From the (main) Reading menu window tap **[+ New]**.

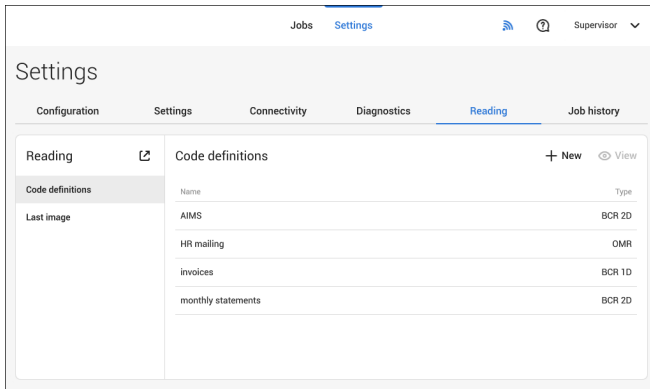

2. Select new code type; BCR 1D or BCR 2D.

Contact your local distributor for more information about available reading licenses.

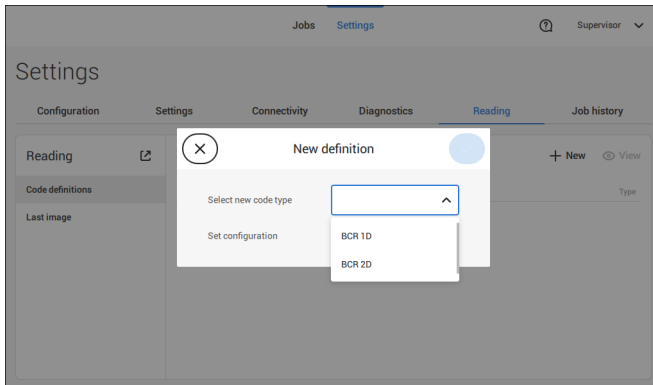

3. Set configuration.

When logged on as Supervisor the only way to set the configuration is via a configuration sheet.

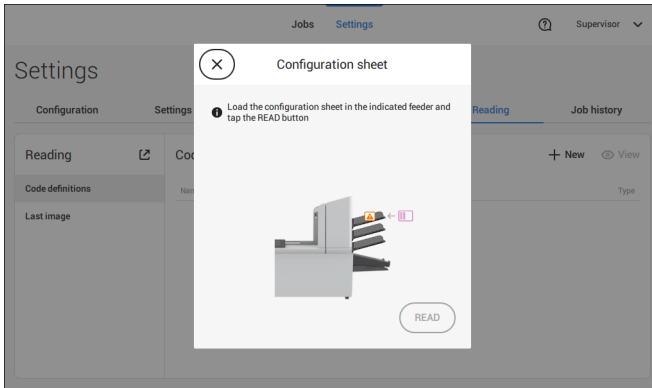

Follow the instructions displayed on screen to finalize the settings of the code definition.

Last Image

The Last image screen shows the result of the last code that the system read. The figure shows an example of the image of a reading code. You can use this image to see if the read code fits within the reading window.

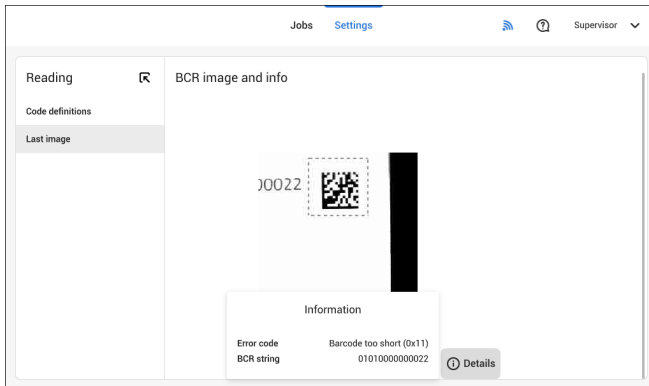

When you click on the Information button of an image of OMR code, the screen shows a graphical representation of the marks read from the last OMR document (oscilloscope function). It shows the time-dependant OMR output voltage.

Job history

The Job history screen shows an overview of the jobs run.

1. Tap on the **[Job history]** tab to view the Job history.

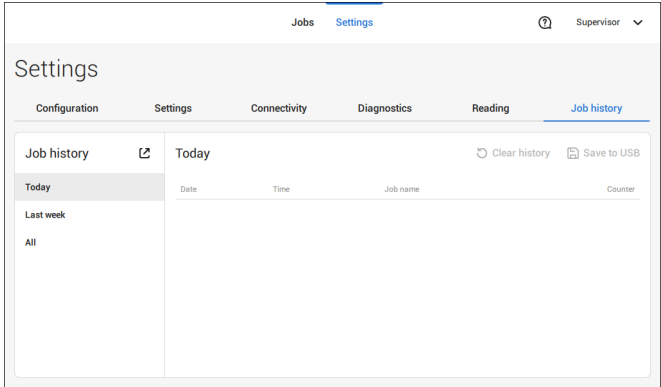

2. Tap either on **[Today]**, **[Last week]** or **[All]** if you want to view the jobs that are run 'Today', 'Last week' or 'All'.

The Job history is displayed on the touch screen. With **[Save to USB]**, you save the Job history in CSV format to a USB drive.

7 Connect the System to the Internet

Options for Connection

Connect the system to the internet in one of the following ways:

- Wired connection with the gigabit ethernet connection:
 - Connect with DHCP (Automatic IP address)
 - Manual Configuration
- Wireless connection:
 - Search for SSID
 - Manually configure SSID

In all cases, you can use proxy for the connection.



Log on as Supervisor to complete this procedure.

Set up a Wired Connection

Set up a wired connection as follows:

1. Connect a network cable between connector **A** and a wall socket of your LAN.



2. Open the supervisor settings menu.
3. Tap the tab [**Connectivity**].
4. Tap [**LAN settings**] and select **Wired** from the **Connection type** pulldown menu.

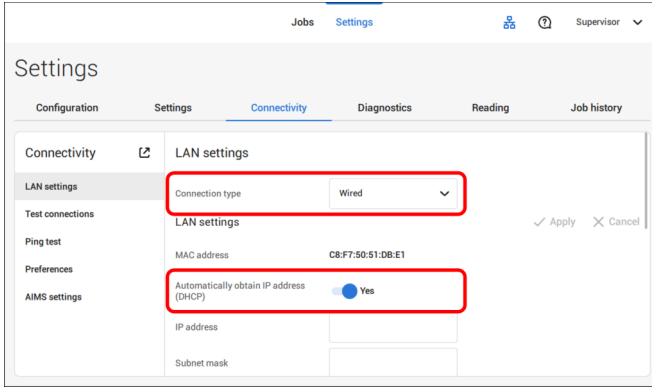

5. Set **Automatically obtain IP address (DHCP)** to **Yes** or **No**. If Yes, the system connects automatically to the LAN. If No, set up a connection manually. Enter the necessary details to setup a manual connection.

Set up a Wireless Connection

Set up a wireless connection as follows:

1. Ensure that the wireless adapter **B** is present.



- Open the supervisor settings menu.
- Tap the tab [**Connectivity**].
- Tap [**LAN settings**] and select **Wireless** from the **Connection type** pulldown menu.

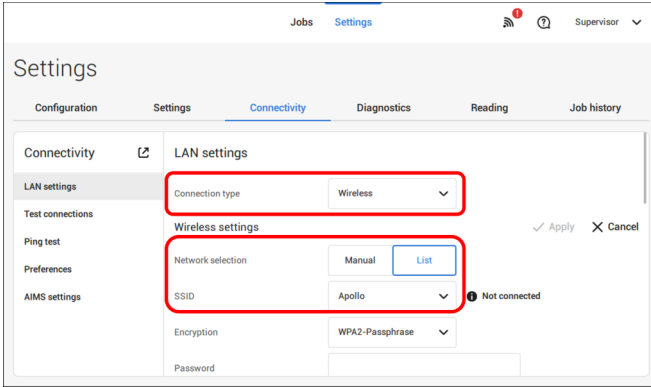

- Tap [**List**] if you want to connect to one of the available networks from the SSID pulldown menu. The system will automatically refresh the list and will show all available networks.

Tap [**Manual**] if you want to enter the SSID manually.

- Enter the password for one of the available SSID networks; [**Apply**] will become active. In case of a manually set network [**Apply**] will become active if all details have been entered.

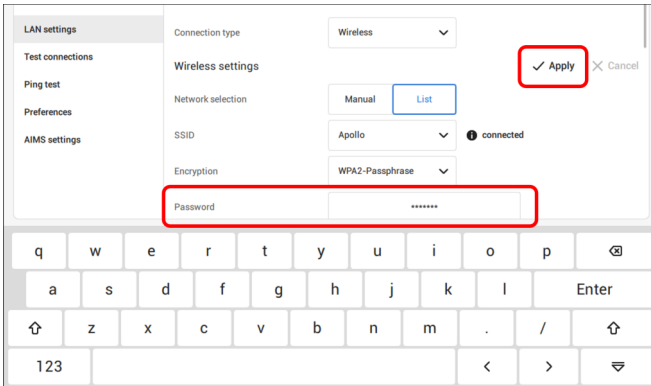

7. Tap **[Apply]**. When the system connected successfully to the network, the screen shows **connected**.

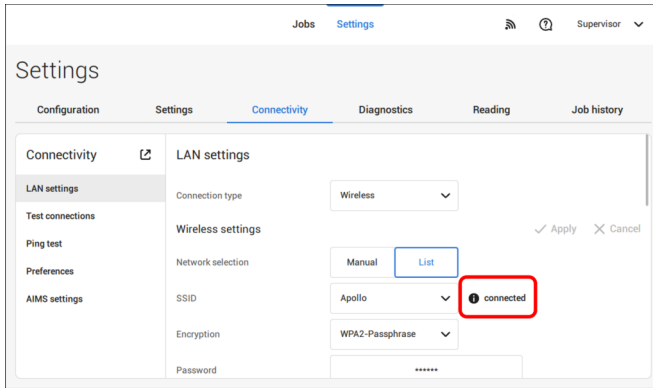

Test the Connection

When you have connected to a network, test the connection as follows:

1. Open the supervisor settings menu.
2. Tap the [**Connectivity**] tab.
3. Tap [**Test connections**].

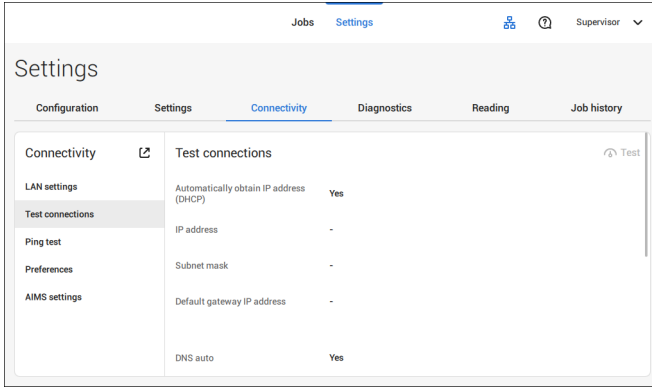

4. Tap the [**Test**] button.

The system tests the IP addresses that are defined at the LAN settings. If the result is 'Not OK', make sure that the settings are correctly defined.

Ping test

If you want to test the network connection between your system and a specific server you can do a PING test. Proceed as follows:

1. Open the supervisor settings menu.
2. Tap the [**Connectivity**] tab.
3. Tap [**Ping test**] and enter the IP address of the server.

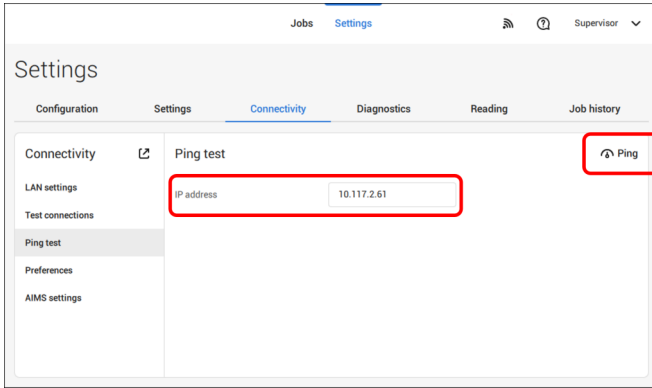

4. Tap [**Ping**] to perform the Ping test.
-

Preferences

The system optionally can share statistics for online reporting. In case the system is not connected to internet or the server can't be reached, the statistics are temporary stored on the system. If the storage is full a warning message can be raised that statistic information will be discarded and will not be available for the online reports. To enable the storage usage warnings proceed as follows:

1. Open the supervisor settings menu.
2. Tap the [**Connectivity**] tab.
3. Tap [**Preferences**] and set "Enable storage usage warnings" to "On".

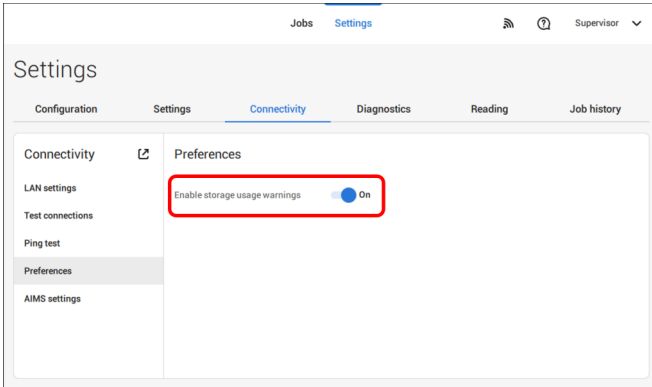

AIMS settings

When operating with AIMS Verification, the server address and port can be configured and the connection to the AIMS server can be tested.

Contact your local distributor for more information about the AIMS option.

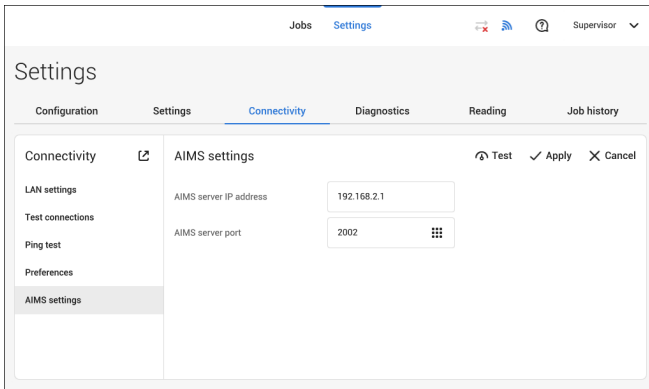

8 Reading

Introduction

Code Types

The reading option allows the system to read special codes that are printed on the documents. The code contains information about the processing of the documents.

The system can read the following code types:

- BCR 1D: One dimensional barcode
- BCR 2D: Two dimensional barcodes
- OMR: 1-track Optical Mark Recognition
- Flex 1-9: Optional translation to support non standard OMR and BCR coding

Depending on the settings, the code tells the system if:

- The document set is complete
- Enclosures must be added to the set
- The system must stop
- The set is complete (no pages are missing)
- The envelopes are transported to the side exit or to the stacker

The sheets with the printed code are placed in a feeder. Depending on the programmed code, the other feeders can be used as selective feeders to add enclosures.

In case of a Z-fold, the address has to be printed on the last page of the set. With the other fold types, the first sheet of a set always contains the address. A full length code is printed on every sheet of a set. The code must appear at the same location on every page regardless of the actual code length.

The code on the last sheet of the set contains the insert instruction. The other sheets carry the accumulate instruction. If the "Page N of M" code is used with BCR, the set will be inserted when N equals M.

General Requirements for Printing Codes

If you print documents for reading:

- Make sure the ribbon or toner quality is sufficient.
- Print the code in black on white background.
- Codes on the same sheet must have equal intensity.
- Print the code at the same position on every sheet.
- Be aware of "background noise". The reading function can be disturbed by: color changes on the form, background design and a logo or copy on the opposite side of the sheet that will bleed through.
- For matrix printers near letter quality (NLQ) printed characters are preferred to obtain maximum blackness (double strike).



For more information on how to print a reading code on your document, contact your service organization.

BCR Code Description

BCR Codes

Bar codes are used for mail sets that are processed in Document Systems. The bar codes tell the system if:

- The document set is complete
- The envelope should be sealed
- Enclosures should be added
- Etc.

Barcode can be printed vertically and horizontally. Two types of barcodes are supported, 1D and 2D barcodes (depending on installed licenses).

For more detailed information on "Bar codes for Document Systems" refer to the [Reading Reference Guide](#).

Supported 1D barcodes

Code 39



Interleaved 2 of 5



Code 128, horizontal printed



Note: A **vertical** printed "Code 128" is **not** supported. It may work but it is not recommended because it is very sensitive to speed variations.

- Minimum line thickness of a bar: 0,20 mm (0.008")
- Maximum line thickness of a bar (smallest element): 0,50 mm (0.02")
- The thickness ratio of thick bars versus thin bars: 2.2
- Preferred print quality: 600dpi
- Minimum width of the barcode: 5 mm (0.2")
- Maximum qty. of characters: 109
- Quiet zone (free white space area): 5 mm (0.2").

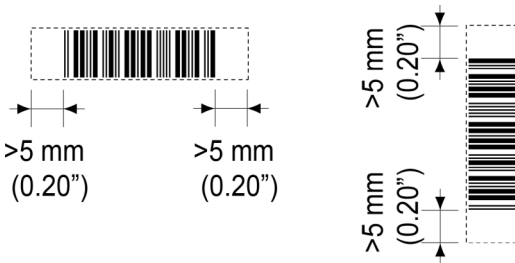

Supported 2D barcodes

Datamatrix



- Minimum cell size 0,30mm (0.012")
- Maximum cell size 0,50mm (0.02")
- Label size 30mm (1.18") square max
- Preferred print quality 600dpi
- Print drift from page to page +/- 2mm max
- Colour background: White
- Datamatrix can be read in all directions
- Minimum white space 2mm (0.08"), all around.

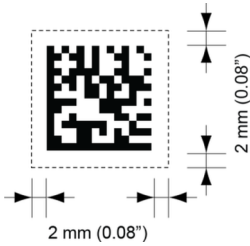

QR



- Minimum cell size 0,30mm (0.012")
- Maximum cell size 0,50mm (0.020")
- Label size 30mm (1.18") square max
- Preferred print quality 600dpi
- Print drift from page to page +/- 2mm (0.08") max
- Colour background: White
- QR can be read in all directions
- Minimum white space 4mm (0.20"), all around.

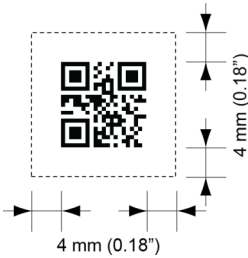

PDF 417



- Bar width 0,35 mm (0.014") min
- Smallest element size 0,5 mm (0.020") max
- Preferred print quality 600dpi
- Print drift from page to page +/- 2mm max
- Colour background: White
- Minimum white space 2mm (0.08"), all around.



Printing contrast

The label must be strongly printed in black on white background for maximum contrast. Other light backgrounds may be acceptable, subject to test.

Position of the code on the document

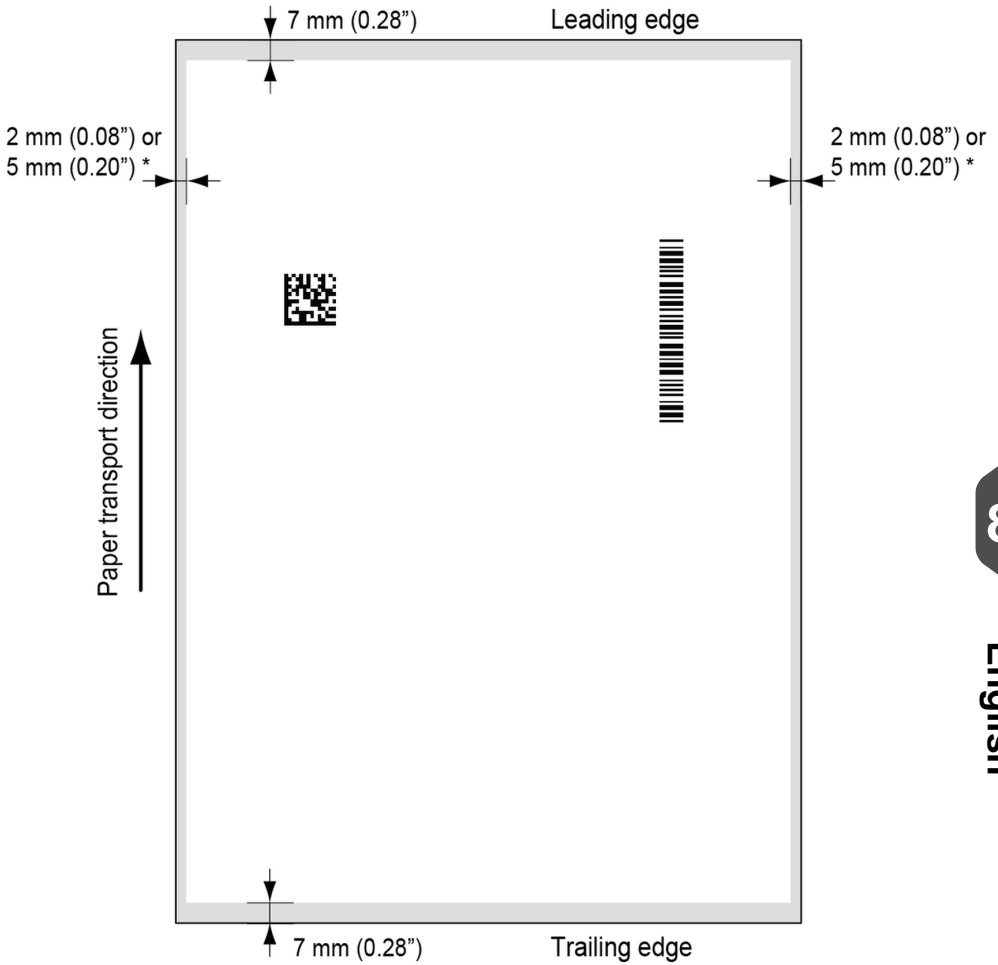

Leading and trailing margins

Barcode should be positioned at least 7 mm (0.28") from the trailing and leading edge of the sheet.

LH and RH margins *

Document width ≤ 210 mm, maintain at least 2mm (0.08") clearance from both side edges.
Document width > 210 mm, maintain at least 5mm (0.2") clearance from both side edges.

BCR license types

There are two BCR license types:

- Basic
- Advanced

BCR basic license

For the BCR basic license the following functions are available:

- Page N of M: defines when a document set is complete and must be inserted into an envelope. As long as N is below M, the document set is not complete. As soon as $N=M$, the set is complete and will be inserted into an envelope.
- Insert/Accumulate: defines when a document set is complete and must be inserted into an envelope.

At least one basic commands is required. Page N of M can be used in combination with Customer ID as an integrity check to prevent different document sets to be inserted into one envelope.

BCR advanced license

For the BCR advanced license the following functions are supported:

- The basic functions (Page N of M, insert/accumulate).
- Sheet sequence - Every sheet has a number, regardless of the document set it is part of. If a sheet is missing, an error is generated.
- Group sequence - Every document in a set has the same group number. If one document set is missing, an error is generated.
- Divert (Divert & Continue) - The set will be diverted and the system continues.
- Stop (Divert & Stop) - The set will be diverted and the system stops indicating error (INS-RE1-000 Reading stop - Stop mark read).
- Selective feed - If the system reads the command, an enclosure from the enclosure feeder is added to the set.
- Sealing control - Determines if envelopes are sealed or not.

OMR Code Description

Position of the code on the document

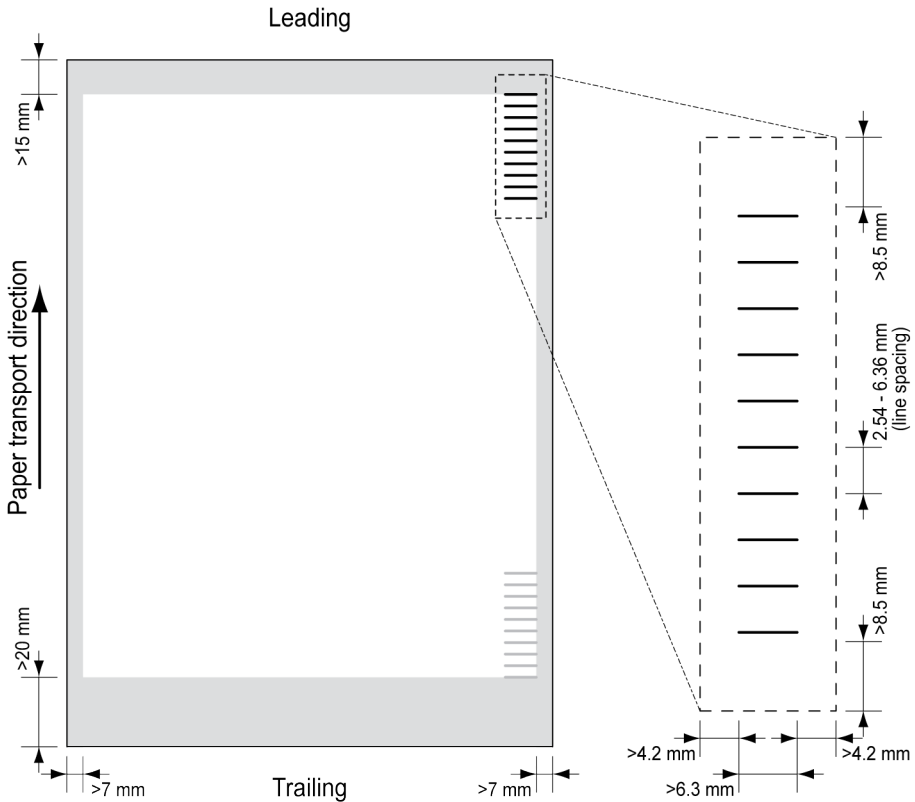

Minimum line thickness of a mark: 0.2 mm (0.008 inch).

Default the first mark from the top is set to: 100 mm (3.9 inch). This parameter is set in the job settings.

The code must have a consistent number of marks on every page.

The white area in the picture shows the limits where the code can be printed.

OMR license types

There are two OMR license types:

- Basic
- Advanced

OMR basic license

For the OMR basic license the following functions are available:

- Start mark: indicates the start of the code.
- Insert/Accumulate: defines when a document set is complete and must be inserted into an envelope.
- Parity check: by adding a parity mark the reading code can be checked. The sum of the marks must be even.
- Safety Mark: is used as an extra security (only 1-track OMR). With skewed paper the reading head can miss part of the reading code. In these situations the safety mark is not read, and the system will give an error. The safety mark also indicates the end of the reading code. This mark must always be present on the document if it is part of the code definition.

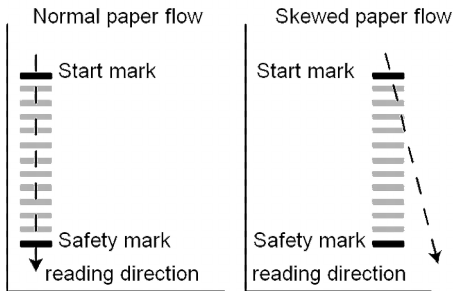

The minimum code is one mark in one line (insert). However for reliability it is advised to use at least 2 marks. The first line is the start mark. A mark printed on the second line means insert. No mark on the second line means accumulate.

OMR advanced license

For the OMR advanced license the following functions are available:

- The basic functions (Start, Insert, Parity, Safety).
- Stop (Divert & Stop) - The set will be diverted and the system stops indicating error (FT1-RE1-000 Reading stop - Stop mark read).
- Selective Feed (feeder 1-3) - If the system reads the command, an enclosure from the enclosure feeder is added to the set. This function is printed on the last sheet of a set.
- Sealing control - Determines if envelopes are sealed or not. If a mark is printed, the envelope is not sealed.
- Sequence Check - Sheets in a stack can accidentally get out of sequence or can be missing. This can be detected by the sequence check. Each sheet has a binary code that is a part of the reading code. Depending on the application one, two or three marks are used by sequence check.

OMR general remarks

General remarks:

- In case of OMR the marks must always be used in the sequence as shown in the figure.

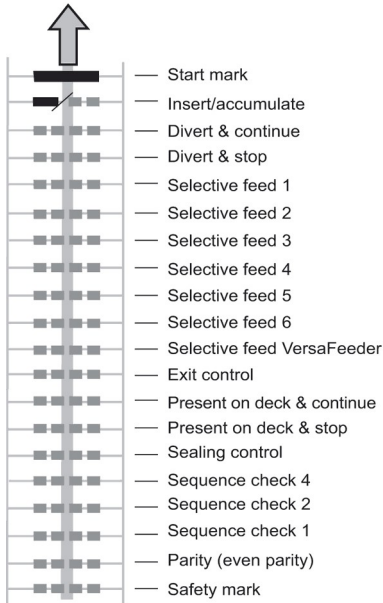

- If a function is suppressed the following function will move upwards one line.
- The mark definition is a service setting.

An Example of OMR Code

In the figure the legend for the following example is shown. In this example, a set of 8 sheets with one selective feed and three sequence check marks is shown.

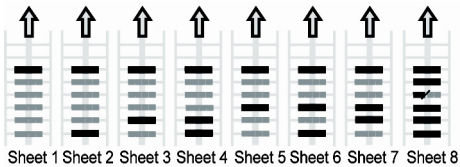

- The first position is used for the start mark which must be printed on every sheet.
- The second mark position is used for the insert/accumulate command. A printed mark means insert, no mark means accumulate. Therefore the mark is printed on the last sheet of the set.
- Position 3 is reserved for selective feed from the enclosure feeder. Print a mark on position 3 when a selective feed from the enclosure feeder is required. The marks are printed on the last sheet of the set.
- Position 4, 5 and 6 are used for the sequence check marks. In this case a three mark sequence check is used.

Flex Reading Code Description

With "Flex reading" also non-standard codes and alternative document handling algorithms can be recognized. Flex reading can be activated by a system specific license code and by a customer specific setting that is saved in a physical dongle.

With Flex three types of reading can be supported:

- OMR
- BCR 1D
- BCR 2D

Depending on the license up to 9 Flex definitions can be used on the system. Creating a Flex job is similar like creating a OMR / BCR reading job.

Create Jobs with Reading

Create a BCR Job

To create a job with BCR:

1. From the Job list, tap **[New job]**.
2. Choose **[Manual]** to define the job settings.
3. Select an envelope.
4. Tap **[Main document]**.
5. Tap **[Settings]** in **Custom** (document) to create a custom document.
6. Enter the document size or select a standard type.
7. Tap the **[Reading]** tab.
8. Select one of the pre-defined BCR code definitions from the pull down menu (code definitions have been programmed by your supervisor or by the service engineer).

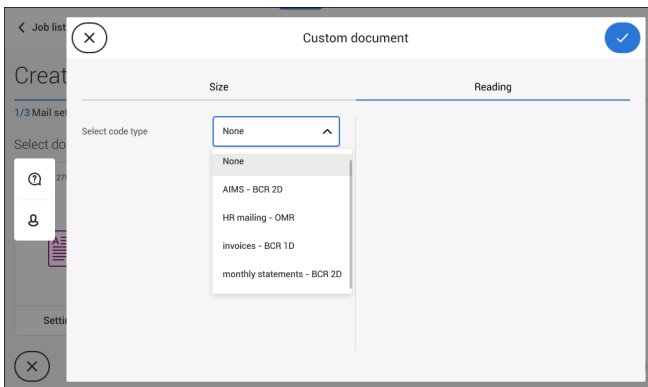

9. Load a sample document in the feeder tray as indicated and tap **[Verify]** to find the barcode(s) on the sheet.
 - If multiple barcodes are found you can select the correct barcode from the list.

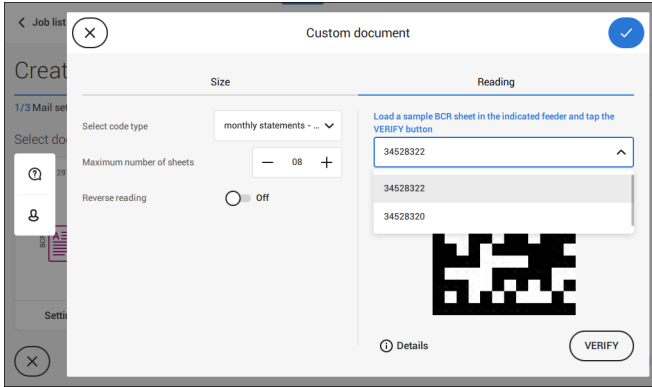

10. Tap **[✓]** and follow the remaining steps to complete the job.
11. When you completed the job creation, tap **[Save]** to save job.

If required the maximum number of sheets can be reconfigured. Refer to [Reading Settings](#) on page 122 for more details on how to change these settings.

Create an OMR Job

To create a job with OMR:

1. From the Job list, tap **[New job]**.
2. Choose **[Manual]** to define the job settings.
3. Select an envelope.
4. Tap **[Main document]**.
5. Tap **[Settings]** in **Custom** (document) to create a custom document.
6. Enter the document size or select a standard type.
7. Tap the **[Reading]** tab.

- Select one of the pre-defined OMR code definitions from the pull down menu (code definitions have been programmed by your supervisor or by the service engineer).

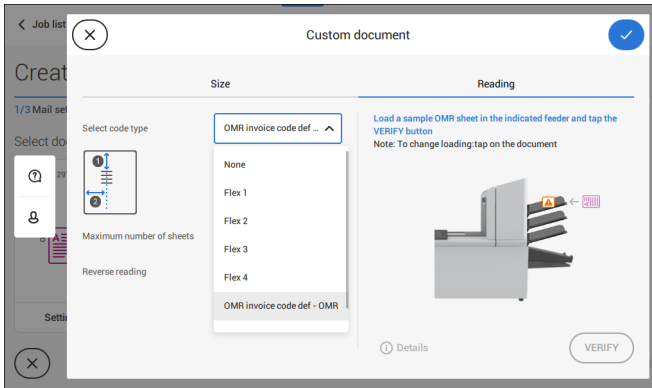

- Load a sample document in the feeder tray as indicated and tap **[Verify]** to read the OMR code on the sheet.
 - After verification the result is displayed. If you tap on **[Details]** information is shown about the OMR reading code.

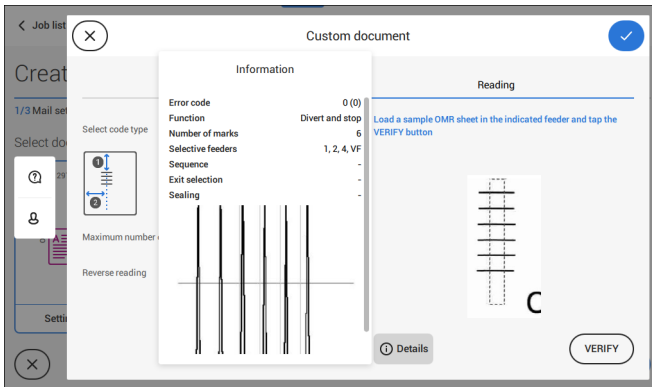

- Tap **[v]** and follow the remaining steps to complete the job.
- When you completed the job creation, tap **[Save]** to save job.

If required the maximum number of sheets can be reconfigured. Refer to [Reading Settings](#) on page 122 for more details on how to change these settings.



Create a Flex Reading Job

To create a job with flex reading:

1. From the Job list, tap **[New job]**.
2. Choose **[Manual]** to define the job settings.
3. Select an envelope.
4. Tap **[Main document]**.
5. Tap **[Settings]** in **Custom** (document) to create a custom document.
6. Enter the document size or select a standard type.
7. Tap the **[Reading]** tab.
8. Select one of the pre-defined Flex code definitions from the pull down menu (code definitions have been programmed by your supervisor or by the service engineer).

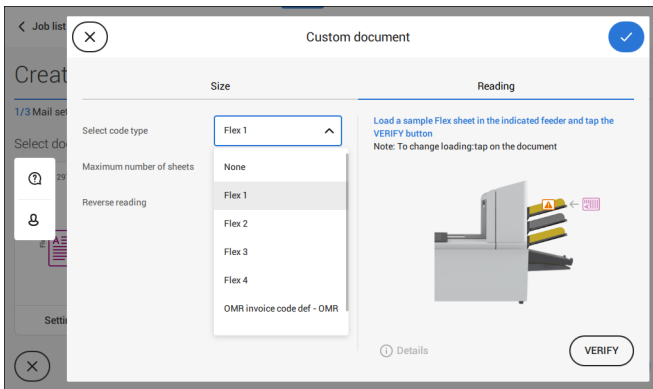

9. Load a sample document in the feeder tray as indicated and tap **[Verify]** to find the Flex code(s) on the sheet.
 - If multiple Flex codes are found you can select the correct Flex code from the list.

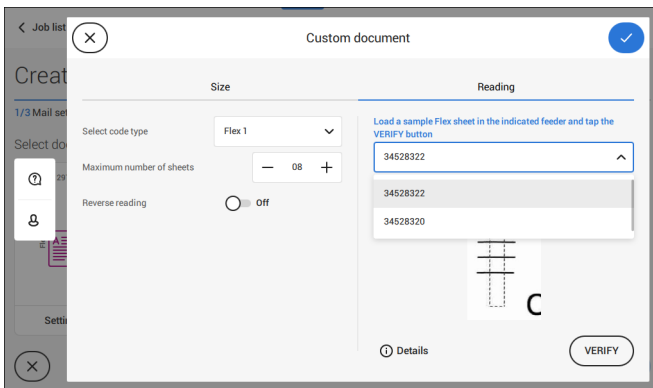

10. Tap [✓] and follow the remaining steps to complete the job.
11. When you completed the job creation, tap **[Save]** to save job.

If required the maximum number of sheets can be reconfigured. Refer to [Reading Settings](#) on page 122 for more details on how to change these settings.

Reading Settings

When you create a reading job for OMR, BCR 1D/2D or Flex reading, the following options can be set:

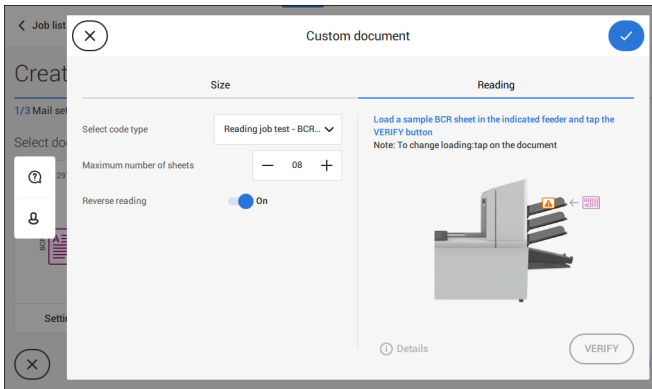

- **Maximum number of sheets:** use the [-] or [+] button to select the maximum amount of sheets in the set of documents.

The maximum number of sheets in a set is 25. When the number of sheets exceeds 5 or 8, depending on the fold, the document can not be folded anymore. In this case, the maximum length of sheets is 148 mm for a C5/6 envelope. Also make sure that the fold is set to No fold. Ignoring this will certainly lead to stoppages.



When the maximum loading number of sheets exceeds the programmed maximum number of sheets in a set, the system stops and error INS-RE1-312 will be displayed. After removing the set and tapping the **[Start]** button, the system starts and repeats the process until an insert or divert mark is encountered. Error INS-RE1-003 (final set part) will be displayed.

- **Reverse reading:** when reverse reading has been set to "On" the decision of inserting a mailset is marked on the next set. For example with OMR the insert mark is printed on the first page of the set. The system will detect the end of a set by detecting the first page of the next set. For example in case of BCR using the Customer ID to complete a set. If the ID changes, the set is inserted.

In case the feeder runs empty, the last set is still on the collator because the beginning of the next set could not be detected. In this case the feeder empty message contains an **[Ignore]** function. Tap **[Ignore]** and the set on the collator will be inserted.

Because of the feeding and collating principle reverse reading has the following limitations:

- The last mark of the code should be printed maximally 85 mm (3.3 inch) from the top.
- Enclosures and selective enclosures cannot be handled. When a versaFeeder module is added to the system configuration, enclosures and selective enclosures can be handled with reverse reading.

9 Operator Maintenance

Maintenance Schedule



Disconnect the mains power supply before performing any maintenance.

The user must not attempt to service the appliance beyond that described in this operator manual. All other servicing must be carried out by qualified service personnel only.

Please contact your authorized distributor.

Maintenance frequency	Maintenance
Daily	<ul style="list-style-type: none">• Check the system functions.• Keep the system in proper condition by removing dust, paper remains, etc.
Weekly	<p>The machine is delivered with an extra set of brushes. To always have one clean set available, it is recommended to soak one set in water and use the other set.</p> <ul style="list-style-type: none">• When dirty or saturated, clean the brushes of the envelope sealing or replace them (see Clean and replace brushes on page 125).• When dirty or saturated, clean the moistening cloth or replace if necessary (see Replace moistening cloth on page 126).• Clean feed and insert rollers as instructed by the Service Engineer.
When needed	<p>When the display warns about dusty sensors, clean the applicable sensors. After cleaning, always calibrate the photocells (see Calibrate photocells on page 127).</p>

Clean and Replace Brushes

When dirty or saturated, clean the brushes of the envelope sealing or replace them as follows:

1. Moisten the new brushes in water.
2. Unlock lever **A** of the upper unit and pull up the upper unit.

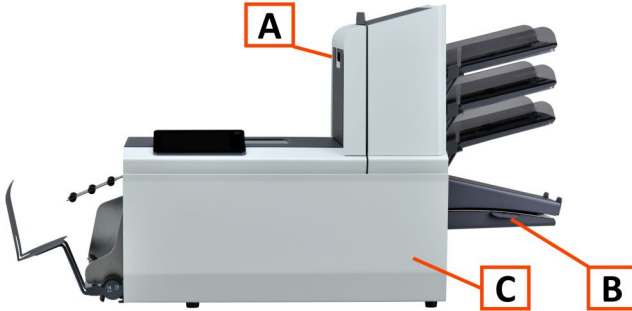

3. Remove the brushes one by one by pulling them down from the brush holder.

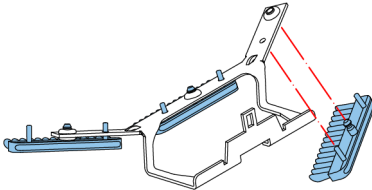

4. Replace the brushes. Make sure that the studs on the brushes are fitted in the corresponding holes in the brush holder.
-

Replace or Clean Moistening Cloth

When dirty or saturated, clean the moistening cloth or replace if necessary. Proceed as follows:

1. Open the front cover **A**.

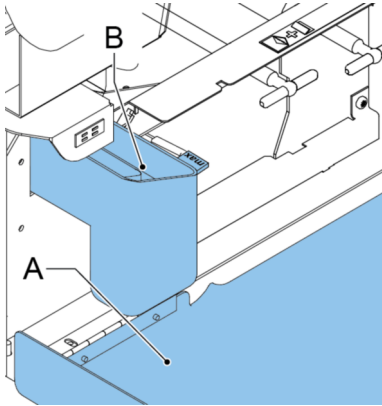

2. Remove the sealing liquid reservoir **B** from the system.
3. Remove the cover with moistening cloth **D**.

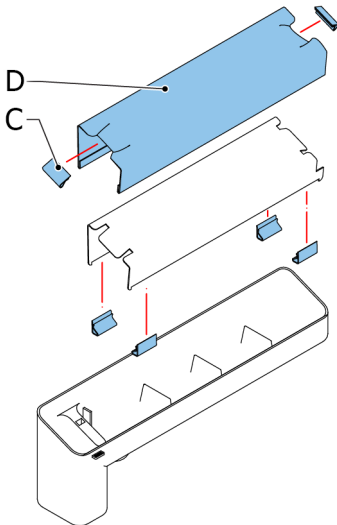

4. Remove clips **C** to remove the moistening cloth.
5. Clean or replace the cloth.

Calibrate Photocells

When too much paper dust is built up at the sensors, a warning message is displayed. In that case, calibrate the photocells as follows:

1. Log in as supervisor.
2. In the settings menu, tap the **[Diagnostics]** tab.
3. Tap **[Photocells]**.

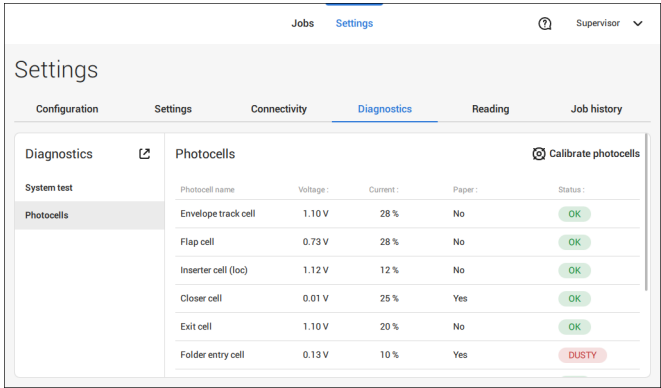

4. Remove all documents and envelopes.



5. Clean the photocells. Place the bellows (item L, section [Operating Controls](#) on page 8) in the upper and lower air plug and firmly squeeze a few times to blow the dust from the document path sensor and envelope path sensor.

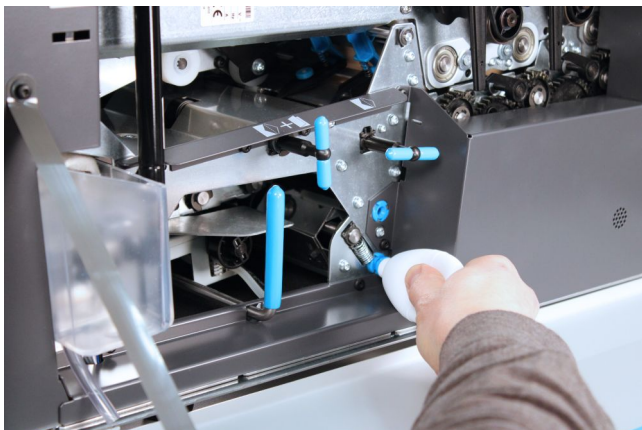

6. To clean the exit sensor place the bellows in the hole for the exit sensor and firmly squeeze a few times to blow the dust from the exit sensor.



7. Close all covers.
 8. Tap **[Calibrate photocells]**.
-

10 Fault Finding

Messages

Introduction

There are three different types of messages:

- Indications
- Warnings
- Errors

Indications

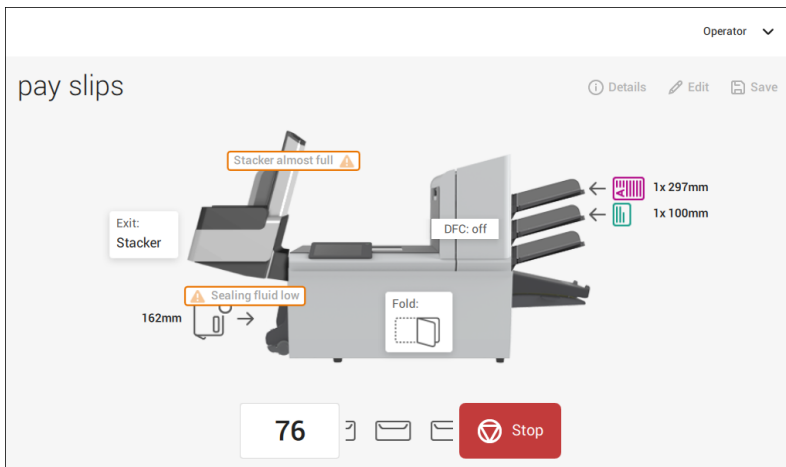

When you run a job, indications can appear like the ones in the example.

Warning message

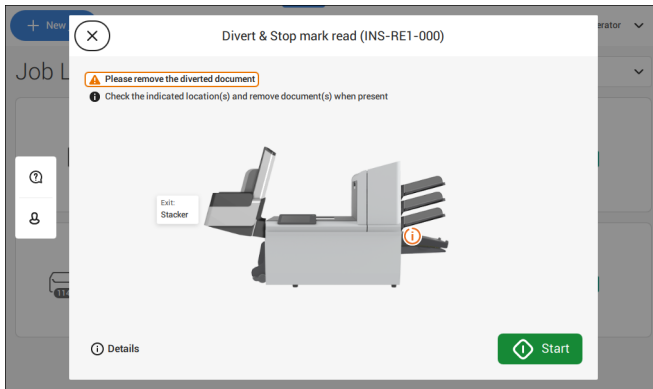

When a warning message is shown, the screen shows the following information:

- An indication of the area in which the event occurred
- A warning description
- A suggested solution behind the arrow
- An event message number; use this number in case that you call support

Tap **(i) Details** to view more information about the event.

Error messages

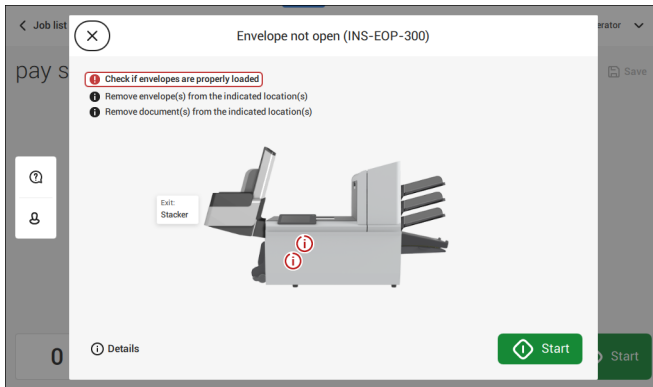

When an error occurs the touch screen shows a screen with the following information:

- An indication of the area in which the error occurred
- An error description
- A suggested solution behind the arrow
- An event message number; use this number in case that you call support

Tap **(i) Details** to view more information about the occurred error and about the possible actions to avoid the error from re-occurring.

After solving the problem, tap **[x]** to reset the error (the error screen will disappear).

Special Errors

- Reading errors (when reading is enabled)
The document set is diverted. The operator must remove the document set and has to complete the set manually!
- Technical errors
The display shows a message. The error cannot be solved by operating personnel and assistance of the service support is needed.

Clearing stoppages

Clearing Stoppages

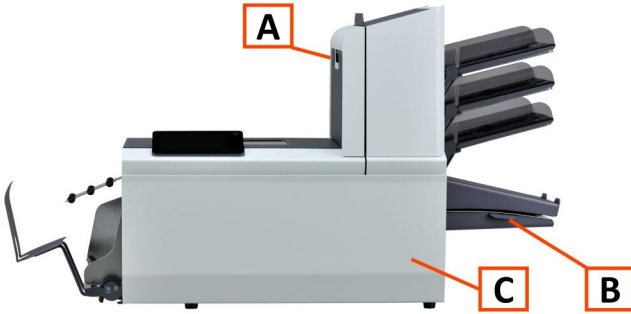

For clearing of stoppages, three system sections can be opened:

A - Top cover (upper unit) to reach the Folder and Feeder area.

B - Collator plate to reach the collator area.

C - Front cover to reach the envelope track and inserter area.

Lower Envelope Track

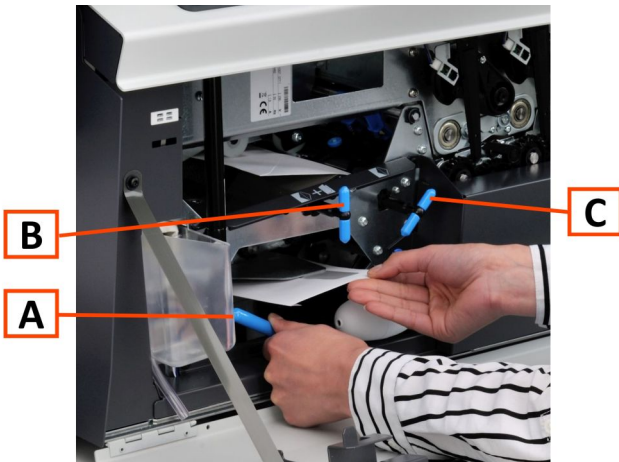

When a stoppage occurs in the lower envelope track, remove the envelopes as follows:

1. Open the Front cover.

2. Lower and hold the handle **A** to the left and remove the envelope(s) from the lower envelope track.
 3. Release the handle **A**.
 4. If necessary, the envelopes and documents can be transported manually by turning the blue knob **C** clockwise.
 5. Turn the blue knob **B** clockwise to manually transport envelopes through the lower envelope track.
 6. Close the side cover.
 7. Press the **[Reset]** button to reset the error and restart the job.
-

Feeder area



When a stoppage occurs in the Feeder area, remove the documents as follows:

1. Open the top cover **A** by pulling up the handle.
 2. Remove the documents from the Feeder area.
 3. Close the top cover **A**.
 4. Press the **[Reset]** button to reset the error and restart the job.
-

Collating Area

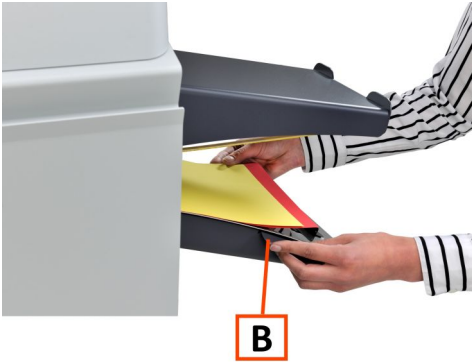

When a stoppage occurs in the collating area, remove the documents from the collating area as follows:

1. Move the collator plate **B** down.
2. Remove the documents from the collator area.
3. Move the collator plate **B** up in position.
4. Press the **[Reset]** button to reset the error and restart the job.

Folder area

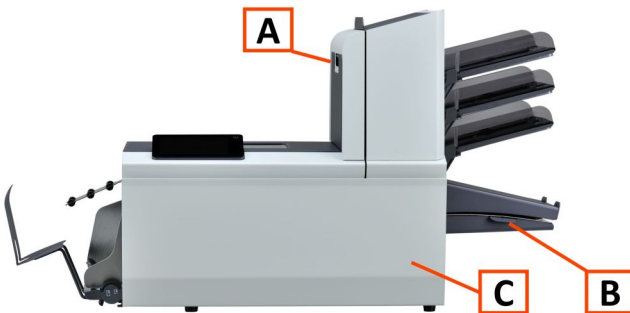

When a stoppage occurs in the Folder area, remove the documents from as follows:

1. Open the top cover **A** by pulling up the handle.
2. Remove the documents from the Folder area.

3. Close the top cover **A**.
4. Press the **[Reset]** button to reset the error and restart the job.

Operator Troubleshooting

To resolve problems:

1. Write down the event message number that is shown in the message on the screen.
2. Try to solve the problem by consulting the Troubleshooting Table.
3. Switch the inserter off and on again, to verify system operation.
4. When the error still occurs contact your service organization.



When contacting the service organization, you will also be asked for the last error message and the software package version of the installed software. To determine the software package version, see Software overview.

Troubleshooting table

Symptom	Possible cause	Remedy	Reference
The system cannot be started after switching on.	System not connected to mains.	Connect the system to the mains.	-
	Fuse is blown.	Replace fuse below power switch.	-
	A cover is opened.	Close the covers.	-
System stops with envelope at insert position (flap not open).	Envelopes stacked reversed in the hopper.	Check envelope feed adjustments. Place envelopes correctly in hopper.	Loading Envelopes on page 72
	Envelope flap sticks.	Store envelopes according to specifications.	Envelope Specifications on page 143
	Wrong envelope type used (not according to specifications or job settings).	Change envelopes according to specifications.	Envelope Specifications on page 143

Envelopes are double fed.	Envelope separation not correctly set.	Adjust envelope separation.	Loading Envelopes on page 72
	Envelopes not placed properly in the hopper.	Check and replace if needed.	Loading Envelopes on page 72
Envelope stops skewed.	Side guides of the envelope hopper are set too wide.	Check side guides and adjust if needed.	Loading Envelopes on page 72
Envelopes are fed irregularly.	Hopper almost empty.	Refill hopper.	
	Separation set too narrow.	Adjust envelope separation.	Loading Envelopes on page 72
	Side guides set too narrow.	Check side guides and adjust if needed.	Loading Envelopes on page 72
	Envelope support not positioned correctly.	Reposition the envelope support.	Loading Envelopes on page 72
Flap is wrinkled and sometimes not opened.	Envelope not within specifications.	Check specifications and change envelopes if needed.	Envelope Specifications on page 143
	Flap sticks.	Store envelopes according to specifications.	Envelope Specifications on page 143
	Flap curled.	Envelopes stored or manufactured improperly.	Envelope Specifications on page 143
	Separation set too narrow.	Adjust envelope separation.	Loading Envelopes on page 72
Fingers are placed on top of the envelope.	Fingers adjusted too deep into the envelope.	Check fingers position, adjust if needed.	Adjust the envelope insert fingers position on page 45
	Envelope stops too early.	Check envelope stop position, adjust if needed.	Verify the Insert Position on page 43

System stops while inserting (stoppage at the inserting point).	Fingers not correctly adjusted.	Check fingers position, adjust if needed.	Adjust the envelope insert fingers position on page 45
	Inserted document too long for used envelope.	Check fold settings.	Editing a job on page 55
	Envelope throat incorrect.	Check envelope specifications.	Envelope Specifications on page 143
	Envelope glued inside.	Eliminate faulty envelopes.	-
	Window not glued properly.	Eliminate faulty envelopes.	-
Flap not sufficiently moistened.	Water level low.	Check water level, refill if needed.	Filling the Sealing Liquid Reservoir on page 75
	Brushes dry.	Check brushes, replace if needed by the extra soaked set.	Clean and replace brushes on page 125
	Brushes dirty.	Check brushes, clean if needed.	Clean and replace brushes on page 125
	Moistening felt dry.	Check the moistening felt, refill water tray if needed.	Filling the Sealing Liquid Reservoir on page 75
	Moistening felt dirty.	Check the moistening felt, clean if needed.	Replace or clean moistening cloth on page 126
	Brushes worn out.	Replace brushes.	Clean and replace brushes on page 125
	Moistening felt worn out.	Replace moistening felt.	Replace or clean moistening cloth on page 126

Envelope not always ejected from sealer.	Inserted document too big.	Check fold settings, adjust if needed.	Editing a job on page 55
	Document not inserted deep enough.	Check adjustment of envelope stop position and fingers.	Verify the Insert Position on page 43
	Sealing area dirty.	Clean sealing area.	Maintenance Schedule on page 124
No document fed.	Feeder tray empty.	Refill feeder tray.	Loading documents standard feeder tray on page 64 Loading documents maxiFeeder on page 68
	Separation set too wide / too tight.	Adjust the separation.	Adjusting the Separation of Special Feeders on page 48 Adjusting the Separation of the maxiFeeder on page 67
	Side guides set too narrow.	Adjust the side guides.	Adjusting the side guides standard feeder trays on page 62 Adjusting the side guides maxiFeeder on page 65
Skewed documents fed.	Side guides set too wide.	Adjust side guides.	Adjusting the side guides standard feeder trays on page 62 Adjusting the side guides maxiFeeder on page 65
Double documents fed.	Separation set too wide.	Adjust the separation.	Adjusting the Separation of Special Feeders on page 48

Document set not correctly inserted.	Insert position not correct.	Check insert position.	Verify the Insert Position on page 43
	Insert fingers not correctly positioned.	Check insert finger position.	Adjust the envelope insert fingers position on page 45
Address not readable from window	Address position not correctly defined.	Check address position.	Adjusting the address position on page 46

11 Specifications

System Specifications

Model	FD6308
Type	Folder and inserter system for medium office use.
Theoretical max. speed	3,800 inserts per hour, depending on application.
Power consumption	Standby: 0.33 W
	Idle: 15.5 W
	Run mode: 160 W
Voltage tolerance	100V: +6% / -10%
	115V: +6% / -10%
	230V: +10% / -10%
Fuse	100/115 Vac: T 5.0 A, 125 V.
	Time lag, 5.0 Amps. rated current, 125 V.
	230 Vac: T 2,5 A H, 250 V.
	Time lag, 2.5 Amps. rated current, high breaking capacity, 250 V.
Approvals	RED (Radio Equipment Directive) 2014/53/EU
	FCC Certificate conform 47CFR, part 15
	CB Certificate conform IEC 62368-1
	UL Listed I.T.E. (Information Technology Equipment), conform UL-IEC 62368-1, file E153801
	Conform NEN-EN-IEC 62368-1 and derivatives.
Noise Level	<66 dBA (according to ISO 11202)
	<67 dBA With High Capacity Vertical Stacker
Operating temperature	10°C - 40°C (50°F-104°F)
Humidity	30%-80%

Hopper and Feeder Capacity

Envelope hopper	325 envelopes (80 g/m ²)
Document feeder tray	325 sheets (80 g/m ²)
High Capacity Document Feeder tray	725 sheets (80 g/m ²)

Configuration Dimensions and Weight

2/3 stations

Height	720 mm (28.3 inch)
	780 mm (30.7 inch) including High Capacity Vertical Stacker
Width	500 mm (19.7 inch)
	630 - 670 mm (24.8 - 26.4 inch) including side exit catch tray
Length*	750 mm (29.5 inch) on covers
	1120 mm (44.1 inch) excluding exit
	1230 mm (48.4 inch) including side exit
	1270 - 1360 (50.0 - 53.5 inch) including catch tray
Weight	1360 mm (53.5 inch) including High Capacity Vertical Stacker
	79 kg (174.2 lbs)

*Production feeder length is 200 mm (7.9 inch) extra

Document and Enclosure Specifications

Paper quality	Minimum 60 g/m ² (15 lb bond) Maximum 250 g/m ² (62.5 lb bond), when folded max. 170 g/m ² (42.5 lb bond) Booklets up to approximately 1 mm (0.04 inch) thickness, depending on stiffness
Paper size	Minimum width: 130 mm (5.1") Maximum width: 242 mm (9.5"), when folded 230 mm (9.1") Minimum length: 90 mm (3.5") Maximum length: 356 mm (14")
Folding capacity	V-fold - 10 sheets (max. 80 g/m ²) C-fold/Z-fold - 8 sheets (max. 80 g/m ²) Double V-fold - 4 sheets (max. 80 g/m ²)
Envelope sizes	Standard BRE (Business Reply Envelopes)
Envelope quality	Minimum 80 g/m ² (20 lb bond) Maximum 120 g/m ² (30 lb bond)

Envelope and Document Set Specifications



When choosing envelopes ensure the envelope size is well between the maximum and minimum specification. Envelopes close to the minimum or maximum size specification are likely not to be the best performing envelopes. Contact your local distributor for advice on the best performing envelopes for your system.

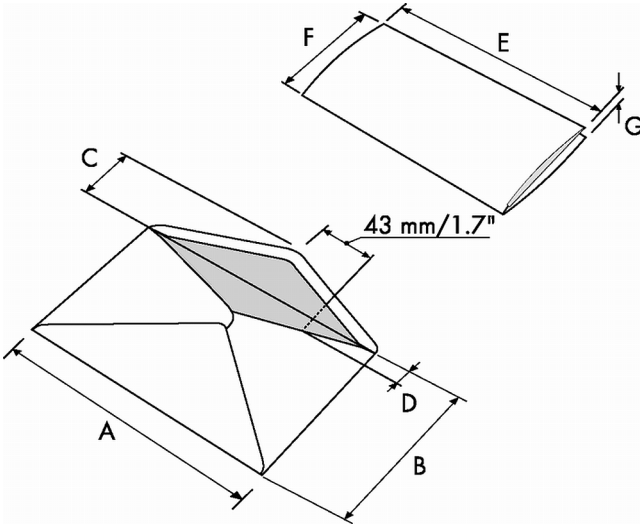

	A	B	C	D	E	F	G
Minimum size	160 mm 6.3"	90 mm 3.5"	32 mm 1.25"	10 mm 0.4"	130 mm 5.1"	84 mm 3.3"	60 g/m ²
Maximum size	248 mm 9.7"	162 mm 6.38"	B-32 B-1.25	35 mm 1.38"	A-12* A-0.47**	B-6 B-0.2	2.5 mm 0.1"

* Booklets up to approximately 1 mm (0.04 inch) thickness, depending on stiffness

** When insert is more than 1 mm (0.04 inch): A-15 mm / A-0.6 inch

Envelope quality	
Minimum	80 g/m ² (20 lb bond)
Maximum	120 g/m ² (30 lb bond)

Remarks:

- The specification of the paper handling equipment is often wider than that of the envelopes and documents handled. The condition of material handled will limit the specified environmental conditions.
- We recommend that materials to be handled are stored at a temperature of 20°C (68°F) with a relative humidity factor of 50%. If difference in temperature occurs between store room and mailing area, the material has to be stored near the machine at least 24 hours before use.

- Self-copying paper may cause rubber parts to wear quicker. The rubber used in this machine has the best resistance to Wiggins Teape material.

Production Feeder Specifications

Model	6308-00
Type	High capacity feeder
Theoretical max. speed	see Technical Specifications
Power consumption	Low voltage supplied by the inserter system.
Approvals	EMC Certificate conform EMC-Directive. FCC Certificate conform 47CFR, part 15. UL Listed I.T.E. (Information Technology Equipment), conform UL-IEC 62368-1, file: E153801. Conform EN-IEC 62368-1 and derivatives.
Height	210 mm (8.3 inch)
Width	285 mm (11.2 inch)
Length	425 mm (16.7 inch)
Weight	5.05 kg (11.1 lbs)
Noise level	see Technical Specifications
Operating temperature	10°C - 40°C (50°F-104°F)
Humidity	30%-80%
Feed tray capacity	1200 sheets A5 80 gr. 325x Business Reply Envelopes
Feed tray capacity 356 mm-Licensed	1200 sheets A4 80 gr. 325x Business Reply Envelopes
Document / BRE insert specifications	See Document Specifications and Envelope Specifications

High Capacity Vertical Stacker Specifications

Model	HCVS-1
Type	High Capacity Vertical Stacker. Suitable for all kinds of mail sets that consist of at least one 80 grams envelope and one folded document (80 gram).
Power consumption	Low voltage supplied by the inserter system.
Approvals	EMC Certificate conform EMC-Directive. FCC Certificate conform 47CFR, part 15. UL Listed I.T.E. (Information Technology Equipment), conform UL-IEC 62368-1, file: E153801. Conform EN-IEC 62368-1 and derivatives.
Height	550 mm (21.7 inch)
Width	440 mm (17.3 inch)
Length	360 mm (14.2 inch)
Weight	12 kg (26.5 lbs)
Noise level	Refer to noise level of the system
Operating temperature	10°C - 40°C (50°F-104°F)
Humidity	30%-80%
Stacker capacity	C5/6 - 1x A4 C-fold: 325 envelopes C5 - 1x A4 single fold: 500 envelopes

12 Terminology

Terminology

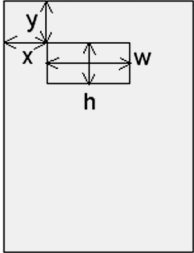
Term	Description
Address carrier	The address carrier is the document that carries the address of the person for who the mail-set is meant. The address must remain visible while enclosures are added and the document-set is folded. The fold type and selected envelope must ensure that the address is visible behind the window in the envelope. For personalized mailings there is always an address carrier present as long as envelope printing is not supported. Normally there is one address carrier.
Address position	 <p>Position of the address on the address carrier, measured from the upper left corner. The address position consists of a horizontal x coordinate, a vertical y coordinate, a horizontal width w and a vertical height h.</p>
Automatic	The feature of an Inserting System to automatically determine its Job settings by measuring the sizes of documents and envelope. From all Feeders that are loaded one sheet will be taken. Based on the maximum document length (which is also the length of the documentset) and the length of the envelope the fold type is determined.
Automatic job	A job that is created with the Automatic functionality.
Barcode Reading (BCR)	Barcode Reading is intended for reading and interpreting printed barcodes. The codes give information to the Inserting system about how to build-up and handle a set.
Business Reply Envelope (BRE)	Envelope included in outgoing mail-sets for addressee response purposes.

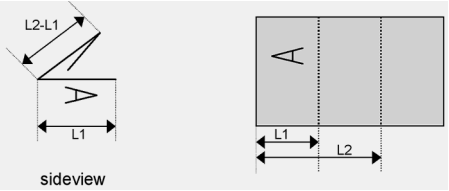
<p>C-fold</p>	<p>Fold type in which a document-set is folded twice in which the folded flaps are on top of each other. This fold is illustrated in the picture below.</p>  <p>The position of both folds is adjustable. Synonym: Letter fold.</p>
<p>Clear</p>	<p>The function of an inserting system in which all mail-sets in progress are finished and the document path is left empty.</p>
<p>Daily Mail</p>	<p>Capability of an inserting system to manually insert mail-sets one by one into the system, which are then inserted into an envelope. Optionally, depending on settings, additional enclosures can be added and the mail-set can be folded. This function is intended for small amounts of mail that each can have a different build-up.</p>
<p>Document</p>	<p>A document is one of the components of a mail-set. A document can consist of one or more sheets. Documents can be divided into address carriers and enclosures. For personalized mailings there is always one address carrier and an optional number of enclosures.</p>
<p>Document-set</p>	<p>The document-set is the physical collection of address carrier and enclosure(s) that is under production in the Inserting System. The document-set is completed during production and is to be inserted in the envelope. The number of enclosures can range from 0 to the limit opposed by the number of available Feeders. Once the document set has been inserted into an envelope it is called mail set.</p>
<p>Double Feed Control (DFC)</p>	<p>Double Feed Control is the sensor that measures the thickness of a sheet to check if the inserting system does not accidentally take more sheets than intended. DFC sensors exist on Feeders (double sheet detection). Currently DFCs on inserting systems perform relative measurements, which means that they need a cycle to 'learn' the thickness of a sheet. Also the length of the document is measured so partly overlapping sheets will be detected.</p>
<p>Double parallel fold</p>	<p>See double V-fold.</p>

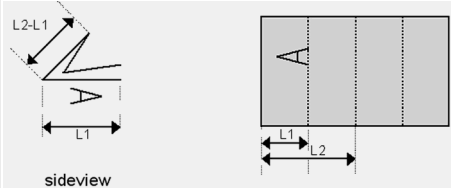
<p>Double V-fold</p>	<p>The double V-fold is a type of fold where the document is first folded halfway and the resulting folded set is again folded halfway. This fold is illustrated in the picture below.</p>  <p>The position of both folds is adjustable. Synonym: double parallel fold.</p>
<p>Envelope</p>	<p>The envelope is the packaging of a mail set. Window envelopes are envelopes that have a transparent section through which the address on the address carrier can be read. Besides the normal top-closing window envelopes there are also bottom-closing envelopes.</p>
<p>Face down</p>	<p>Situation in which the front of a sheet is facing downwards when placed in a document feeder.</p>
<p>Face down leading</p>	<p>Situation in which the front of a sheet is facing downwards and the top of the sheet is closest to the separation unit in a document feeder.</p>
<p>Face down trailing</p>	<p>Situation in which the front of a sheet is facing downwards and the bottom of the sheet is closest to the separation unit in a document feeder.</p>
<p>Face up</p>	<p>Situation in which the front of a sheet is facing upwards when placed in a document feeder.</p>
<p>Face up leading</p>	<p>Situation in which the front of a sheet is facing upwards and the top of the sheet is closest to the separation unit in a document feeder.</p>
<p>Face up trailing</p>	<p>Situation in which the front of a sheet is facing upwards and the bottom of the sheet is closest to the separation unit in a document feeder.</p>
<p>Feeder</p>	<p>A Feeder is a Module for the input of documents to the inserting system. The Feeder separates documents sheet by sheet from the stack of documents in the feed tray.</p>
<p>Feeder linking</p>	<p>The ability to load two feeders with the same document type where the Inserting System automatically switches to a second feeder when the first feeder is empty and vice versa. In the mean time the first feeder can be refilled, so the inserting system can keep running without having to stop for refilling the feeders.</p>
<p>Feed tray</p>	<p>Part of the feeder that contains the stack of documents.</p>

Flexcode OMR/BCR	An OMR/BCR code for which the meaning of the marks can be programmed in a dedicated way for a specific customer. This is normally used to support the OMR/BCR codes from other suppliers.
High Capacity Vertical Stacker (HCVS)	Optional stacker that is mounted on the exit of the system, to stack filled envelopes.
Insert	<ul style="list-style-type: none"> • An insert is the action of inserting a document-set into an envelope. • For native English speaking customers an insert is also a short, not to be folded document, usually an enclosure.
Inserter	An Inserter is the Module where the document-set is inserted into the envelope, the envelope is closed and if necessary sealed.
Inserting system	The system of all the Modules that cooperate to perform the inserting function (accumulate document-set, fold and insert) and have a single point of control.
Job	A job is an actually produced collection of mail-sets based on a certain Job Definition at a certain point in time for a specific purpose. It consists of: <ul style="list-style-type: none"> • The Job definition used for the production • Information about the batch size
Job counter	The counter that registers the number of mail-sets that is produced as part of a specific job.
Letter fold	See C-fold.
Linking	See Feeder Linking.
Loc	The Loc is the unit in the system that transports the envelope just after the document was inserted. It is called Loc (short for locomotive) as the early developments had a straight cover and a number of transportation rollers sticking out. This made it look like a locomotive from the side. In the current systems the loc also carries the brush holder and sealing rollers.
Prod. Feeder	Feeder with high capacity feed tray (e.g. 1200 sheets A4 80gr).
Multifeed	The feature of an Inserting System in which more than one sheet is taken from a Feeder.
OMR	Optical Mark Recognition
OMR code definition	Standard 1-track OMR code definition. Specifies the amount of reading marks used and the functionality linked to each of them (how each should be interpreted).

Operator	The person operating a document system.
Optical Mark Recognition (OMR)	Optical Mark Recognition is intended for reading and interpreting printed codes. These codes are one or more black marks which are read from a document. These marks give information to the Inserting system about how to build-up and handle a set.
Reading error	Condition in which the system could not reliably read or interpret the OMR reading marks or barcode from a sheet.
Reading marks	Marks added to documents containing finishing instructions that can be identified by a reading head and interpreted according to the used OMR code definition.
Service engineer	Technical engineer whose task it is to resolve problems with systems in the field. Besides dealing with problems, service engineers are also responsible for preventive maintenance.
Single fold	See V-fold.
Stop counter	Counter which sets the amount of envelopes to be filled. After filling this amount of envelopes the system will stop (even during a clear).
Supervisor	Person who is responsible for the technical state of the machine. Normally a supervisor has access to programming functions, which are restricted for standard users.
Test run	A test run is intended to validate the settings of the Inserting System: <ul style="list-style-type: none"> • Inspect and adjust the stop position of the envelope. • Check the fold settings for one set. • Check if the address is correctly positioned behind the envelope window.
Thickness detection	Checks the thickness of the document set. If the thickness is less or more than the set value an error message is displayed.
Tray	Contains a stack of paper for a printer or inserter. This paper is supplied to the machine for further processing.
V-fold	A V-fold implies the document/set is folded once. The fold-position is adjustable. This fold is illustrated in the picture below: <div data-bbox="255 1182 708 1377" data-label="Image"> </div> <p>sideview</p> <p>Synonym: Single fold.</p>

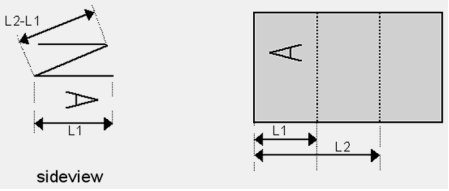
Vertical transport	The vertical transport section between feeders and collator.
Z-fold	<p>A Z-fold means that a document is folded twice in such a way that each folded flap is on a different side of the folded document, resulting in a Z-shape. This fold is illustrated in the picture below.</p>  <p>The position of both folds is adjustable. Synonyms: zigzag fold</p>