

# FORMAX<sup>®</sup>

---

AP3  
Address Printer

OPERATOR MANUAL  
First Edition

---

## SAFETY PRECAUTIONS

THIS EQUIPMENT PRESENTS NO PROBLEM WHEN USED PROPERLY. OBSERVE SAFETY RULES WHEN OPERATING THE PRINTER. BEFORE USING PRINTER, READ THIS MANUAL CAREFULLY AND FOLLOW RECOMMENDED PROCEDURES, SAFETY WARNINGS, AND INSTRUCTIONS:

### WARNING:

**Hazardous Moving Parts. Keep Fingers and Other Body Parts Away.**

### ATTENTION:

**Pièces mobiles dangereuses. Veuillez que les doigts et les autres parties du corps sont à l'écart.**

- ✓ Avoid touching moving parts or materials while machine is in use. Before clearing a jam, be sure machine mechanisms come to a stop.
- ✓ Always turn machine off before making adjustments, cleaning machine, or performing any maintenance covered in this manual.
- ✓ Use power cord supplied with machine. Plug it into a properly grounded, easily accessible wall outlet located near machine. Failure to properly ground machine can result in severe personal injury and/or fire.
- ✓ Power cord and wall plug are primary means of disconnecting machine from power supply.
- ✓ **DO NOT** use an adapter plug on line cord or wall outlet or remove ground pin from line cord. Avoid using wall outlets that are controlled by wall switches, or shared with other equipment.
- ✓ **DO NOT** route power cord over sharp edges or trap it between furniture. Make sure there is no strain on power cord caused by jamming it between equipment, walls or furniture.
- ✓ **DO NOT** remove covers. Covers enclose hazardous parts that should only be accessed by a qualified service representative. Report any cover damage to your service representative.
- ✓ This machine requires periodic maintenance. Contact your authorized service representative for required service schedules.
- ✓ To prevent overheating, do not cover vent openings.
- ✓ Use this equipment only for its intended purpose.

In addition, follow any specific occupational safety and health standards for your workplace or area.

This manual is intended solely for the use and information of Formax, its designated agents, customers, and their employees. The information in this guide was obtained from several different sources that are deemed reliable by all industry standards. To the best of our knowledge, that information is accurate in all respects. However, neither Formax nor any of its agents or employees shall be responsible for any inaccuracies contained herein.

Hewlett-Packard is a registered trademark of Hewlett-Packard Corporation.

Windows is a registered trademark of Microsoft Corporation.

All other trademarks are the property of their respective holders.

All rights reserved. No part of this book may be reproduced or transmitted in any form or by any means, electronic or mechanical, including photocopying, recording, or any information storage and retrieval system, without permission in writing from the publisher.

---

---

## Table of Contents

<b>SECTION 1 – <i>Getting Acquainted</i></b>	<b>1</b>
Operator View	1
Rear View	2
Control Panel	3
<b>SECTION 2 – <i>Install Printer</i></b>	<b>5</b>
Before using Printer:	5
Contents of Packaging	5
Assemble Printer	5
Install Side Guides	6
Install Rear Media Support and Wedge	6
Connect Printer	7
Install Inkjet Cartridges	8
Setting up Feed	9
Install Printer Driver	11
<b>SECTION 3 – <i>Operating Printer</i></b>	<b>13</b>
Using the Touchscreen	13
Shutdown/Reset Button	28
Transport/Pass-Through Button	28
Firmware Updates	29
Quick Menu	30
Printer Driver Properties	31
<b>SECTION 4 - <i>Maintenance</i></b>	<b>35</b>
Inkjet Cartridge	35
Cleaning Printhead	36
Purging Nozzles	37
Jams in Printer	37
Replace Sheet Separators	37
Cleaning	38
Feed Rollers and Forwarding Rollers	38
Cleaning Media Sensor	38
Cleaning Touchscreen	38
<b>SECTION 5 – <i>Troubleshooting Guide</i></b>	<b>39</b>
HP Inkjet Print Cartridges	39
Printer	40
Touchscreen Messages	41
<b>APPENDIX A – <i>Specifications</i></b>	<b>42</b>
<b>APPENDIX B – <i>Supplies and Optional Hardware</i></b>	<b>43</b>
Supplies	43
Optional Hardware	43
<b>INDEX</b>	<b>44</b>



## SECTION 1 – *Getting Acquainted*

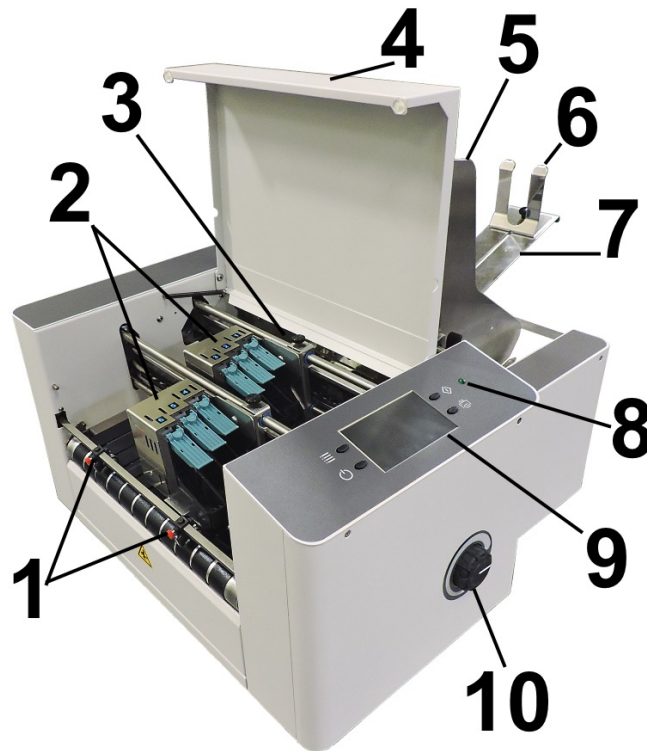

### *Operator View*

1.	<b>EXIT ROLLERS</b> – Help media to exit Printer. Assemblies are repositionable. Position so they provide media drive but are out of the print-area.
2.	<b>PRINT UNITS</b> – Contains two repositionable Print Units. Each Print Unit contains three Printheads (ink cartridges). Each Print Unit has the ability of printing a ~1.5" high image. A continuous image up to ~3" high can be printed when both Print Units are combined.
3.	<b>MEDIA SENSOR</b> – Senses media as it enters the Printhead area. Sensor is located between the first Print Unit (Heads 1,2,3) and Feed Rollers.
4.	<b>TOP COVER</b> – Encloses the Print Area.
5.	<b>MEDIA SIDE GUIDES</b> – Position media in Printer.
6.	<b>MEDIA SUPPORT WEDGE</b> – Holds media against Front Plate.
7.	<b>REAR MEDIA SUPPORT</b> – Supports media while it is being fed.
8.	<b>POWER INDICATOR LIGHT</b> – Shows that main power is ON.
9.	<b>CONTROL PANEL TOUCHSCREEN</b> – Touchscreen allows access to Printer menus and controls to set up and operate the Printer. Four <b>Control Keys</b> to access or operate <b>Quick Menu, Shutdown/Reset, Transport ON/OFF, Feeder ON/OFF</b> .
10.	<b>MEDIA THICKNESS ADJUSTMENT KNOB</b> – Adjusts height of Printhead Carriage to compensate for different media thicknesses. <b>NOTE: Always raise Printhead Carriage to uppermost position when storing Printer.</b>

**SECTION 1  
GETTING ACQUAINTED**

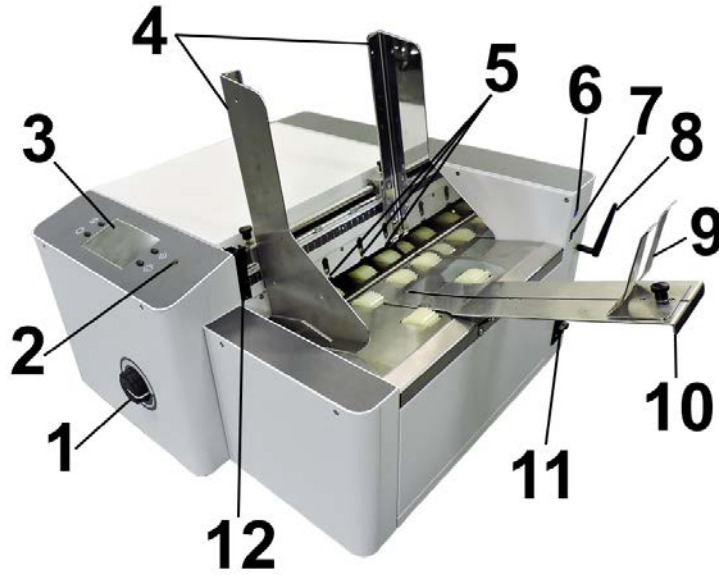

**Rear View**

1.	<b>MEDIA THICKNESS ADJUSTMENT KNOB</b> – Adjusts height of Printheads to compensate for different media thicknesses.
2.	<b>POWER INDICATOR LIGHT</b> – Shows that main power is ON.
3.	<b>CONTROL PANEL TOUCHSCREEN</b> – Touchscreen allows access to Printer menus and controls to set up and operate the Printer. Four <b>Control Keys</b> to access or operate <b>Quick Menu, Shutdown/Reset, Online/Offline, Pause/Print</b> .
4.	<b>MEDIA SIDE GUIDES</b> – Used to position and guide media into the Printer.
5.	<b>SHEET SEPARATORS</b> – Used to separate a single piece of media from the stack. There are four sheet separators on this printer.
6.	<b>USB 3.1 PORT</b> – Connects Printer to your computer. <i>(Also supports USB 2.0)</i>
7.	<b>ETHERNET PORT</b> – Connects Printer to a network.
8.	<b>WI-FI PORT</b> – Connect Wi-Fi antenna <i>(included)</i> to monitor or operate Printer wirelessly through your network.
9.	<b>MEDIA SUPPORT WEDGE</b> – Allows for adjustments in stack angle, based on media type and length. Helps to force the media against the separation area.
10.	<b>REAR MEDIA SUPPORT</b> – Provides the proper angle to enhance paper feeding and separation.
11.	<b>MAIN POWER SWITCH, POWER RECEPTACLE AND FUSE</b> – Power cord plugs in here. <b>WARNING:</b> Verify that the receptacle shows the correct voltage <b>115V</b> or <b>220V</b> selection. <b>Switch</b> turns Main Power ON/OFF. <b>Fuse</b> provides over-current protection. <b>WARNING:</b> Press the ON/OFF Button, located on the control panel, to properly shut-down the printers electronics before turning off the Main Power Switch. <b>CAUTION:</b> Double pole/neutral fusing. For continued protection against risk of fire, replace only with same type and rating of fuse.
12.	<b>SEPARATOR LOCKING LEVER</b> – Unlocks/locks Sheet Separators to adjust Separators for different media thicknesses.



### *Control Panel*

<b>1.</b>	<p><b>QUICK MENU KEY</b> – Allows quick access to often-used Printer functions without having to scroll through a number of screens. <b>Test Feed/Reprint, Horizontal and Vertical Alignment, Printer Preferences, Purge Print, and Ink Status.</b></p> <p>Press <b>Quick Menu</b> key again to return to previous screen.</p>
<b>2.</b>	<p><b>SHUTDOWN/RESET KEY</b> – The <b>Shutdown Printer</b> screen opens with 6 button options: <b>Reset, Shutdown, USB Disconnect, Sleep Now, Software Reload, Port Reset</b> and <b>Cartridge Initialize.</b></p> <p><b>Shutdown</b> button safely powers-down printer electronics. It is very important that this is done before shutting off the Main Power Switch.</p>
<b>3.</b>	<p><b>TRANSPORT ON/OFF KEY</b> – Turns the Transport Motor ON and OFF. Press to turn Transport OFF. Also used to temporarily run the Transport to clear media from under the Printheads.</p>
<b>4.</b>	<p><b>FEEDER ON/OFF KEY</b> – Turns the Feeder ON and OFF. Provides a quick way to print and pause a job at the Printer without using the Touchscreen or computer. Press to start printing. Press to pause a running job. Press key again to resume printing.</p> <p><b>NOTE:</b> After pausing a job, pressing this key starts both Feeder and Transport.</p>
<b>5.</b>	<p><b>CONTROL PANEL TOUCHSCREEN</b> – Use the Control Panel Buttons to open certain screens and/or use the Touchscreen arrow and screen icons to operate the Printer and set and adjust Printer settings and functions. You can also check Printer status and error messages.</p>
<b>6.</b>	<p><b>POWER INDICATOR LIGHT</b> – ON (illuminated) when Main Power Switch is ON.</p>

**NOTE:** A complete description of the functions and operation of the Touchscreen can be found in [Section 3 – Operating the Printer.](#)





## SECTION 2 – *Install Printer*

### *Before using Printer:*

- Choose a location for Printer
- Assemble Printer
- Plug in Printer and connect it to computer
- Install Inkjet Cartridges
- Set up feed on Printer
- Install Printer Driver software on computer



### *Choose a Location*

Printer should be placed on a sturdy worktable or cabinet at least 12" (30.5 cm) from any walls. Protect Printer from excessive heat, dust, and moisture – avoid placing it in direct sunlight.

### *Contents of Packaging*

1.	AP3 Printer
2.	Power Cord
3.	Wi-Fi Antenna
4.	CD or Thumb Drive (Includes Printer Driver, Operator Manual)
5.	Side Guides
6.	Rear Media Support & Wedge
7.	USB Cable
8.	Network Cable

### *Assemble Printer*

**Tools required:** Standard #2 Phillips head screwdriver.

## SECTION 2 INSTALLING PRINTER

---

### *Install Side Guides*

1. Remove two screws [A] from each Side Guide Block.
2. Align Side Guide screw holes with holes in Side Guide Blocks.
3. Insert screws removed in **Step 1**. Tighten so Guides are firmly attached to Side Guide Blocks.

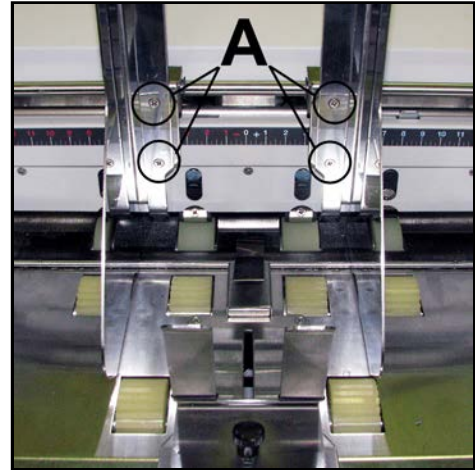

### *Install Rear Media Support and Wedge*

1. **Install Rear Media Support.** Use two screws [A] (*included*) onto the Rear Center Plate.
2. Install two screws [B] into top of Rear Center Plate.
3. **Install Media Support Wedge.** Insert Locking Knob [C] through Media Support Wedge and Rear Media Support. Screw into rectangular washer [D].

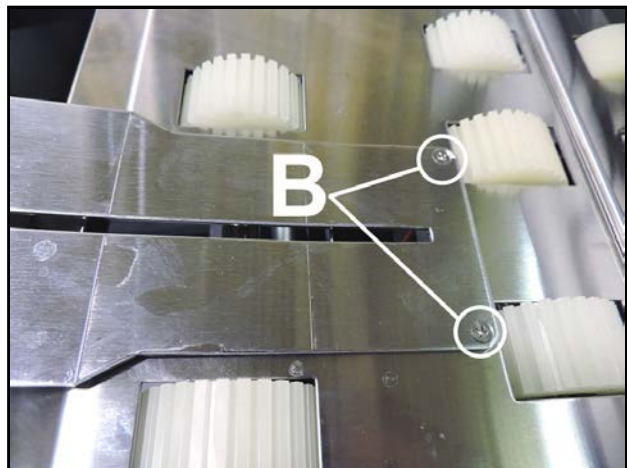
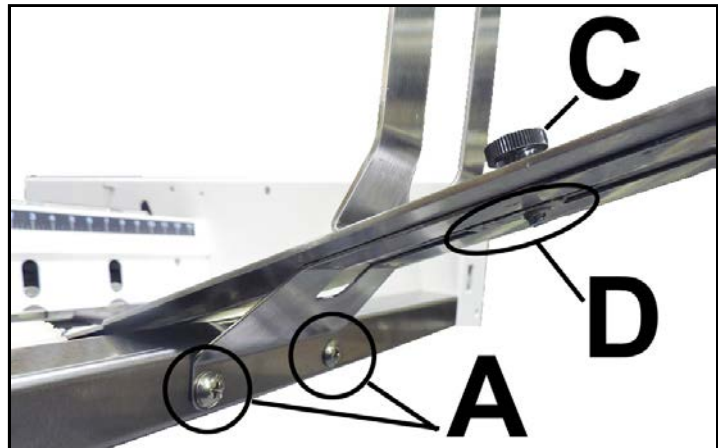

## Connect Printer

### Plugging in Printer

Make sure Printer's Main Power Switch is turned OFF.

1. Verify that the Printer is set for the voltage to be used/connected (115V or 220V) [A].
2. Connect one end of the power cord to the rear receptacle on the Printer.
3. Plug other end into a 115-220 Volt AC (depending on Printer voltage section), 50/60 Hz. grounded outlet.

#### CAUTION

**DO NOT USE ADAPTER PLUGS OR EXTENSION CORDS TO CONNECT PRINTER TO WALL OUTLET.**  
**DO NOT USE WITH OUTLETS CONTROLLED BY WALL SWITCHES.**  
**DO NOT USE WITH OUTLETS THAT SHARE THE SAME CIRCUIT WITH LARGE ELECTRICAL MACHINES OR APPLIANCES.**

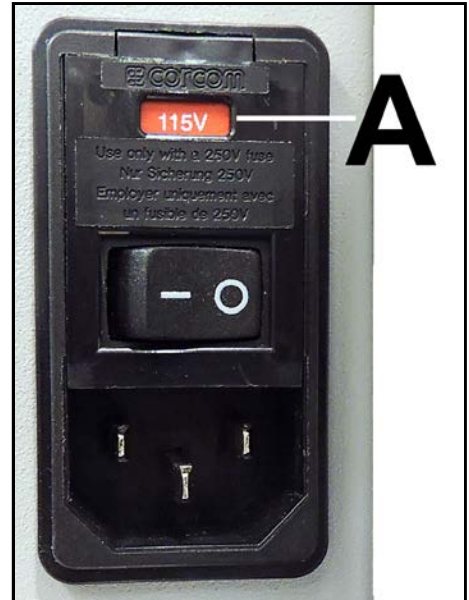

### Connect to Computer or Network

**USB 3.1 Port:** Plug USB cable into connector [1]. Cable used to connect Printer to computer must not exceed 6 feet long. Can be used with USB 2.0 port/cable as well.

**Ethernet (Network) Port:** Plug network Ethernet cable into Ethernet connector [2].

**Wi-Fi Port:** Connect Wi-Fi antenna (included) to this port [3] for wireless Printer monitoring or operation through your network.

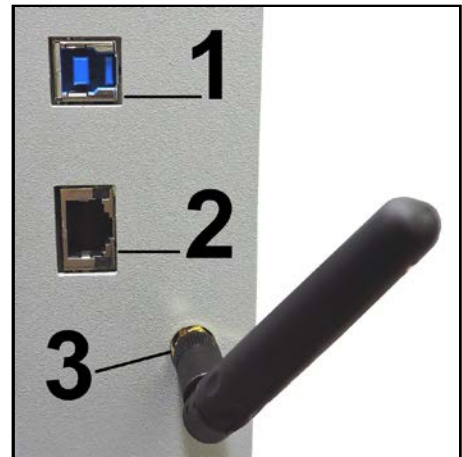

## SECTION 2 INSTALLING PRINTER

---

### *Install Inkjet Cartridges*

Printer has 6 Inkjet Cartridges. **To install Cartridges:**

#### CAUTION

**For continued protection against possible fire, use only authorized Ink Cartridges. 40mL max ink for each cartridge. Flashpoint shall be > 93.3C per Material Safety Data Sheet.**

1. Remove Inkjet Cartridge from packaging. Take care not to touch copper contacts, metal plate, or gold printhead. Remove protective tape from Printhead.
2. Open Latch Lever mounted on Inkjet Cartridge Holder.
3. With Cartridge's Printhead pointing down, slide Cartridge into Holder. Push down and toward contacts in the Printhead Holder.
4. Make sure Cartridge is seated in Holder. Close Latch Lever to secure Cartridge. **DO NOT** force Latch Lever into place.
5. Repeat **Steps 1-4** for remaining Inkjet Cartridges.



**Ink in Cartridge may be harmful if swallowed. Keep new and used Cartridges out of reach of children. Discard empty Cartridges immediately.**

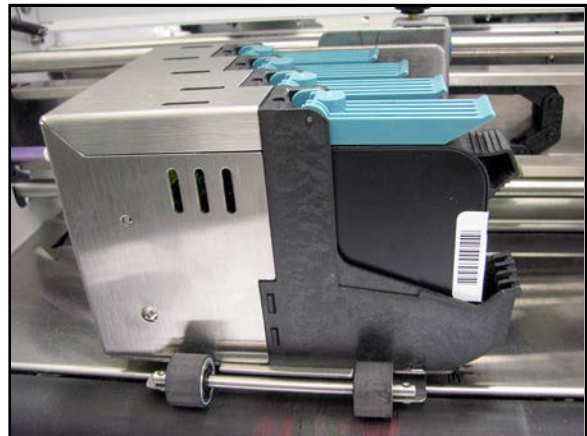
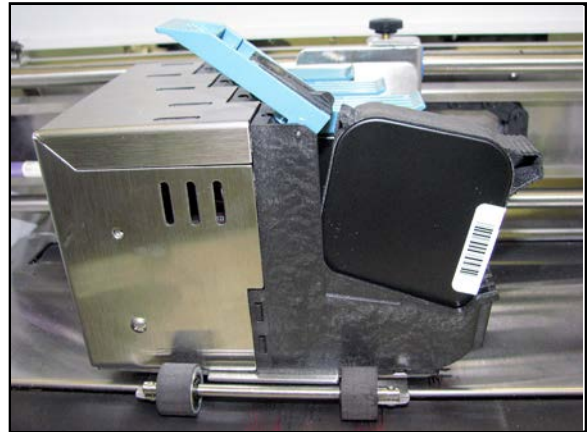

## Setting up Feed

1. Release Separator Locking Lever **[A]** (located on operator's side of Feeder), then raise Separators **[B]** to "up and locked" position. Move Media Side Guides **[C]** to outermost open position. Place one piece of media in center of Feed Table.
2. **Adjust Separators.** Use two Center Separators for narrow media and all four Separators for wide media. Place media under the Separators and lower the Separators so they rest on media.
3. Rotate the Locking Lever up to lock the Separators in place.

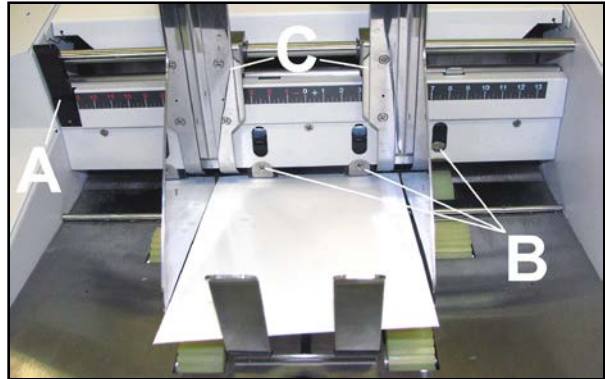

4. Loosen knobs on Media Side Guides. Adjust Side Guides to within 1/32" (0.8 mm) of media. Tighten knobs.
5. Adjust Media Support Wedge **[D]** so media is raised about 1/2" (12 mm) and rests on curve of Wedge. Then tighten Locking Knob.  
**NOTE:** When running 10" (254 mm) or longer or heavy media you may have to set Wedge so that it just touches back of media.

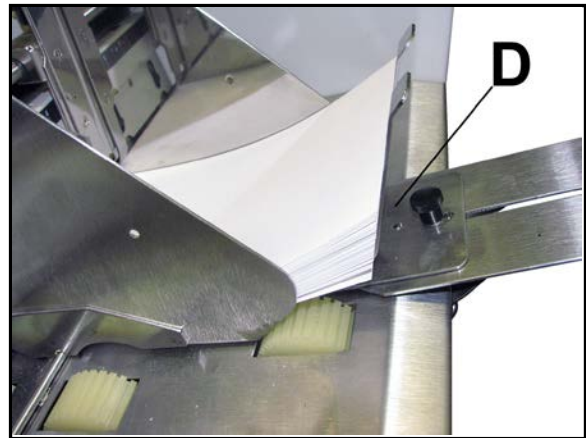

6. Adjust two Exit Rollers **[E]** towards each side of the printer; so they are out of the way.
7. Turn Media Thickness Knob **[A]** fully clockwise to raise the Printhead Carriage to its highest position.
8. Slide a piece of media **[B]** under Printheads 4,5,6.  
**Tip:** Be careful not to slide media in too far. You don't want media to be positioned under the Pressure Rollers that area located at the exit of Printheads 1,2,3.
9. Adjust the Media Thickness Knob **[A]** counterclockwise until the bottom of the Print Unit just touches the media. Then remove the media.  
**Tip:** If the media can not be pulled out easily, from under the Print Unit, turn Media Thickness Knob counterclockwise until media **[B]** can be pulled from under Print Unit with only a slight drag.

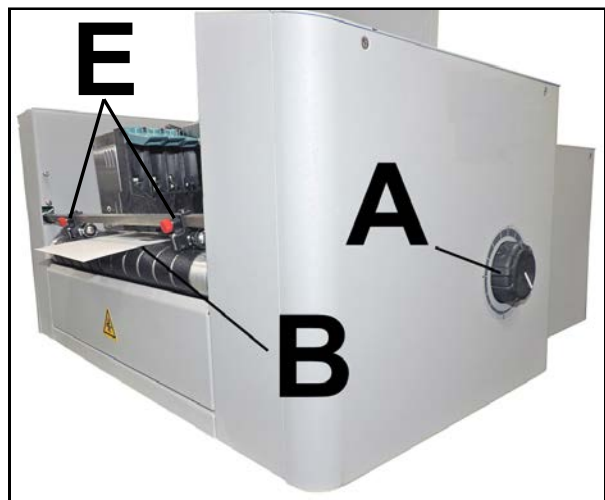

**NOTE:** These are initial settings. It may be necessary to adjust the Media Thickness Control to optimize print quality. Make a note of the knob position for future reference for that media.

## SECTION 2 INSTALLING PRINTER

---

8. Turn Printer ON.
9. Test feed media by pressing “Test Feed” on the Quick Menu Touchscreen.
10. Adjust two Exit Rollers [E] so that they ride on media.  
To prevent smearing, make sure that Exit Rollers do not track over any printed information.

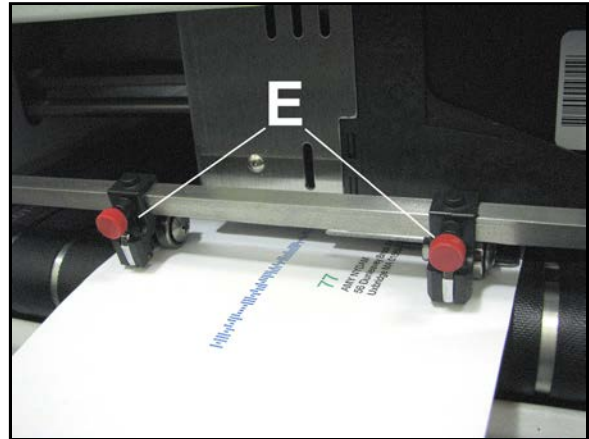

## *Install Printer Driver*

1. **Open the Printer Driver Folder:** Select and double-click “*Setup.exe*”.
2. “*Add, Update or Delete Printer*” window opens. Click “**Add New Printer**”. Click **Next>**.
3. The “**Connect Printer**” window opens. Make sure the Printer is plugged in and switched on and that it is connected by USB, Network or WiFi to your computer. Click “**Yes**”.
4. The “**Want to Install Printer...**” window opens. If that is correct. Click “**Yes**”.

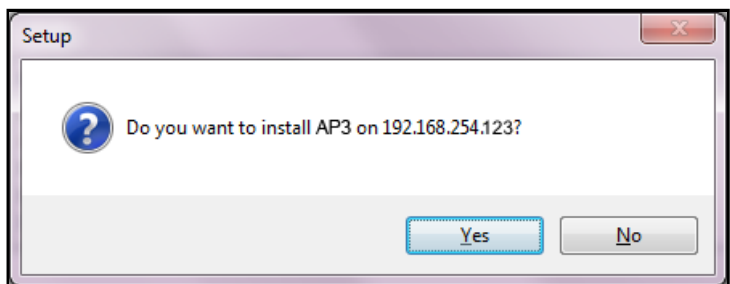
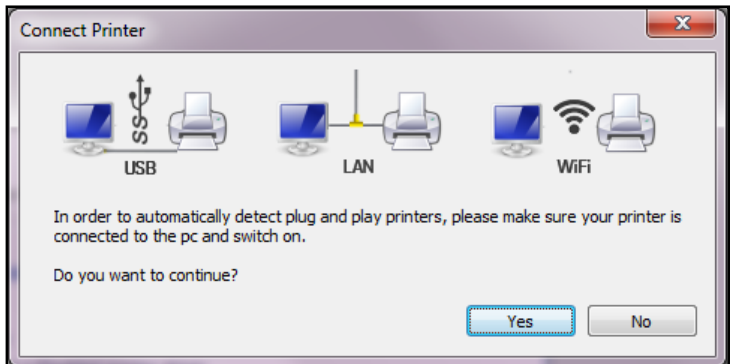
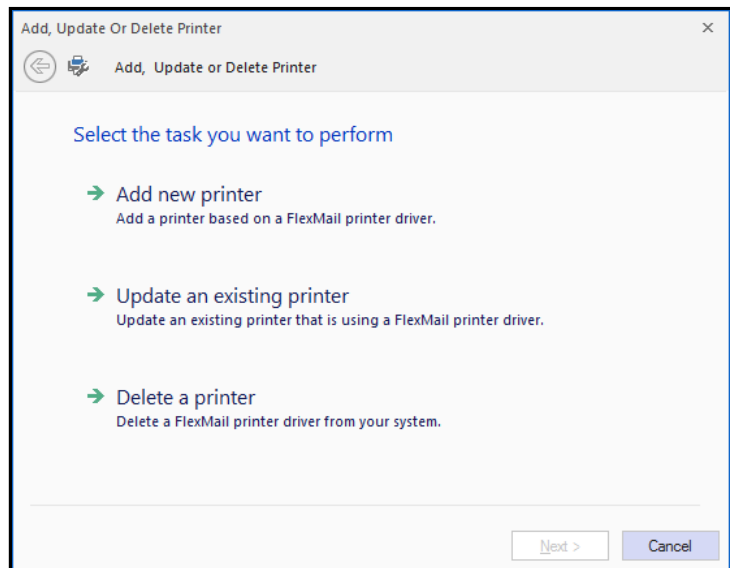

## SECTION 2 INSTALLING PRINTER

5. The Driver will load and the next screen allows you to “**Name Your Printer**”. Unless another printer has the same name on your system or network, ignore this step and click **Next>**.
6. Click **Finish** to complete the installation.
7. In “**Devices and Printers**” check that Printer is available and active.
8. **Using the Printer Touchscreen:** Press the **Network** icon on the **Tools** screen to open the **Network Settings** screen. Select **Network Setup** to enter the settings for connecting the Printer to your network. **Uncheck** the **DHCP** box. This will ensure that the Printer's IP address won't change each time the Printer is powered down.

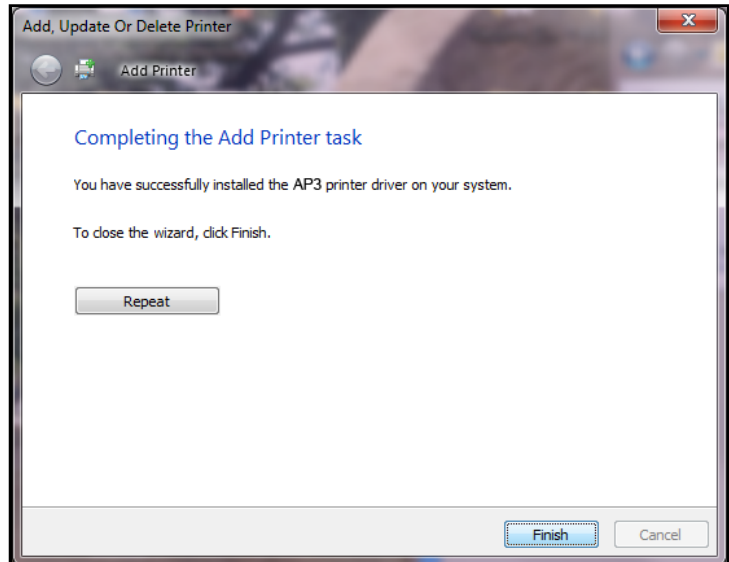
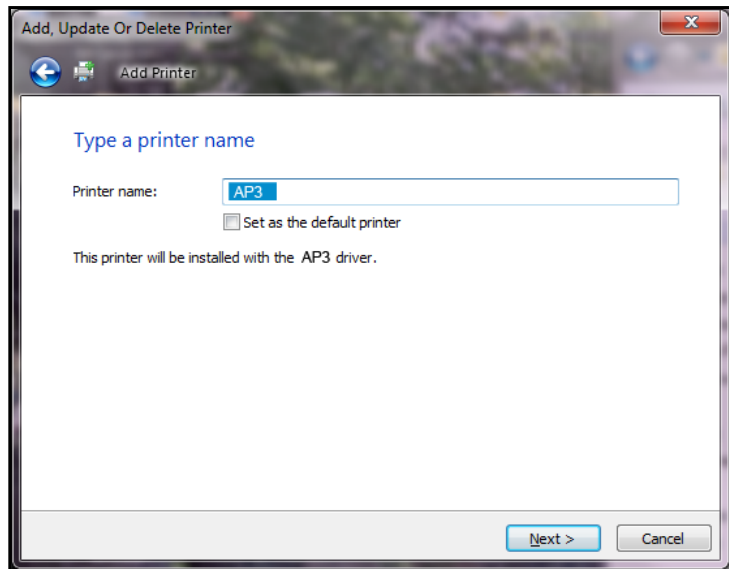
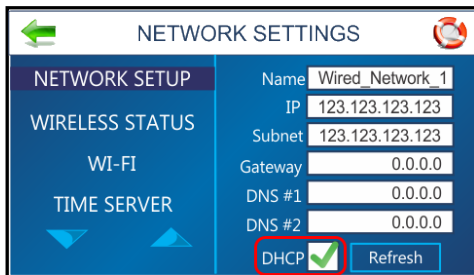



## SECTION 3 – *Operating Printer*

**Control Panel Touchscreen** or through the **Printer Driver** loaded on your computer. The “**Operating Printer**” section is divided into two parts. The first describes the function of the **Printer Control Panel Touchscreen**. The second section describes **Driver Properties** and various options available when running a job.

**Printer Driver** installed in **Section 2** should be set as the default driver. It is then accessible through your applications. Other types of applications and database management software will work in a similar manner using the **Formax AP3 Driver**. This Section further assumes that feed is set up and Printer is connected to your computer.

### *Using the Touchscreen*

The **Control Panel Touchscreen** turns on when the Printer is turned on.

NOTE: The Touchscreen will turn off (go into sleep mode) if it isn't pressed for 60 minutes. Touch the touchscreen to wake the Touchscreen.

Use the Touchscreen and/or Printer Control Panel keys to access various functions that help you control or customize Printer operation.

### BASIC TOUCHSCREEN INFORMATION

**Green Arrow:** Tap or press to return to the previous screen.

**Help Icon (Life Preserver):** Tap or press the icon to open a short description of the features found on that screen.

**Cleaning:** See “**Cleaning the Touchscreen**” in the **Maintenance** section.

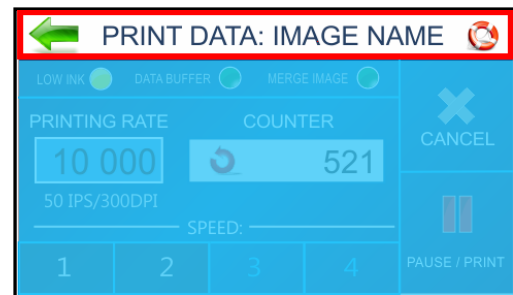

## SECTION 3 OPERATING PRINTER

---

### TOUCHSCREEN KEYBOARDS

Use the **Touchscreen Keyboards** when entering or editing information in entry boxes in features such as **Network Settings**. The appropriate keyboard opens when you tap on an **Edit Box** and/or tap within a data entry box on the Touchscreen.

- “**C**” to the left of the white entry box clears the box.
- “**Arrow**” to the right of the white entry box deletes last character entered.
- Press “**Enter Arrow**” on lower right of keyboard to save your entry.
- Press “**Up Arrow**” to toggle between upper and lower case letters.
- “**SP**” is the space bar.
- “**123**” opens the numeric keyboard.
- “**#+=**” on the numeric screen opens the symbols keyboard.

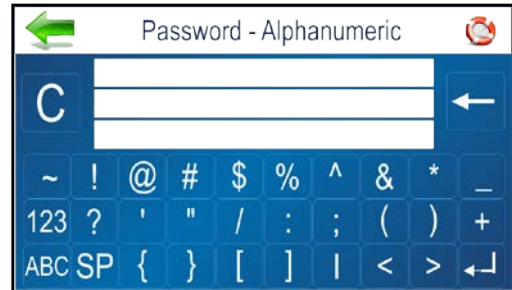
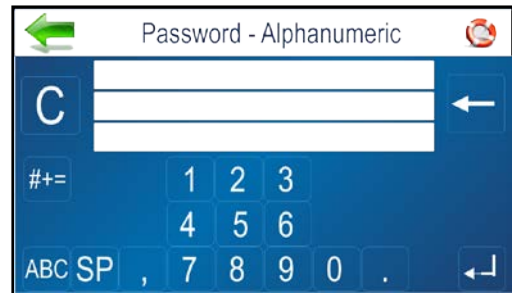
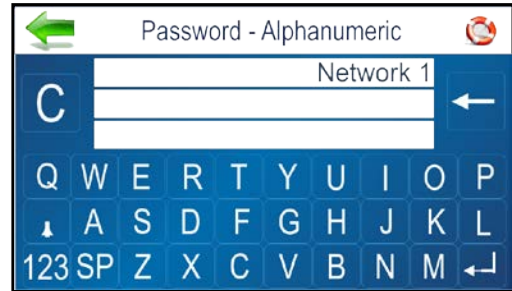

## MAIN MENU

Tap or press the icons to access features built into the Printer and to customize Printer operation.

**Print Image:** Select, Import or Delete an image. Imported images are stored within printer. Print image or Merge image with next job.

**Printer Set-up:** Set Printer parameters to adjust the Printer to suit your needs.

**Tools:** Run **Ink Cost Estimator**, **Ink Status**, **Diagnostic tests**, **Network**, and **Screen Calibration**.

**Print Data:** Displays information about the job printing.

**Test Print:** Prints a test page using current adjustments and print parameters to check printing quality and Printhead alignment.

**Info:** Displays information about the Printer.

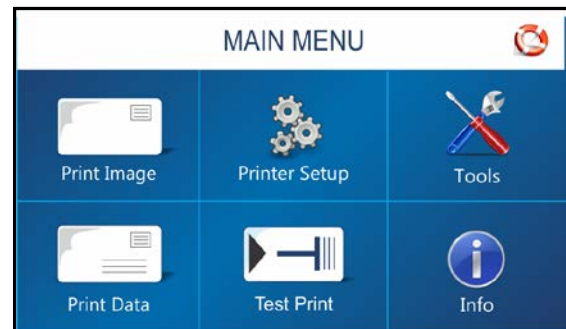

## PRINT DATA

Shows information about the job currently printing.

**Low Ink:** Indicator appears when ink is running low.

**Data Buffer:** Indicator shows data buffer condition.

**Red**-No job data loaded. **Green**-Job data loaded.

**Flashing**-Job data loading.

**Merge Image:** Indicates Merge Image status.

**OFF**-No Merge Image selected/loaded.

**Green**-Merge Image selected/loaded. When Job is sent, each record in the Job will be printed along with the selected Merge Image. See “Print Image” for details on loading and selecting a Merge Image.

**Merge Clear Button:** Press to clear the Merge Image (stop image merge process) and continue printing without having to cancel the job.

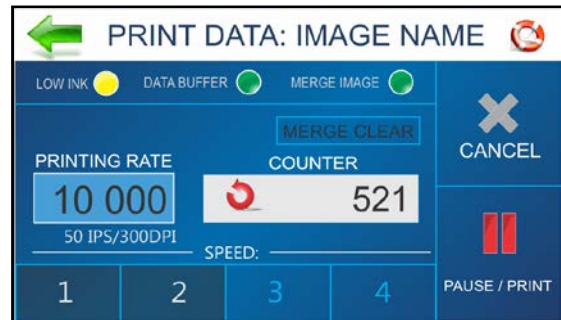

**Printing Rate:** Shows how many pieces are printing per hour. Also displays the **Speed (ips)** and **Print Quality (dpi)** set for the print job.

**NOTE:** A technician can select “units of measurement” (English/Metric, Inches/Feet) within Service Mode.

**Counter:** Shows the number of pieces run for a particular job or accumulated jobs (continuous batch counter).

**NOTE:** “Continuous Batch Counter” can be enabled or disabled from Printer Preferences Menu.

Use **Reset Button**, inside Counter box, to reset the counter to zero (0).

**Speed:** Shows print speeds (1-4) available for a print job. Available speed selections will vary with Print Quality. 150DPI = Speed 1,2,3,4. 200DPI = Speed 1,2,3. 300DPI = Speed 1,2. 600DPI = Speed 1

**Cancel:** Cancels a paused print job.

**Pause/Print:** Press to print a job, pause a running job, or to restart a paused job.

**NOTE:** You can also perform these functions using the Feeder ON/OFF button on the Control Panel.

## SECTION 3 OPERATING PRINTER

---

### INFO

Displays information about the Printer.

**Model Name:** Printer model.

**BIOS version:** Current version of firmware installed.

**Max. Printheads:** Number of Printheads in this model Printer. (*x's or number = printhead installed. -'s = printhead missing or problem.*)

**Firmware Notice:** Displays firmware status. The

**CLEAR** button removes the notice.

**Clock:** Displays current time.

**Cartridges used:** Total number of ink cartridges emptied by the Printer.

**Pieces-Lifetime:** Total number of prints that passed through the Printer. Non-resettable.

**Jobs:** Total number of jobs run on the Printer lifetime.

**Session:** Total number of jobs run on the Printer since last power-down.

**Port(s) in Use:** Displays which Printer ports are available for use. It will also show if an active WiFi connection is currently established and provide WiFi Name.

**NOTE:** A technician can disable or enable Printer ports from the “Service Menu”. Disabling unused ports can speed printer boot-up process.

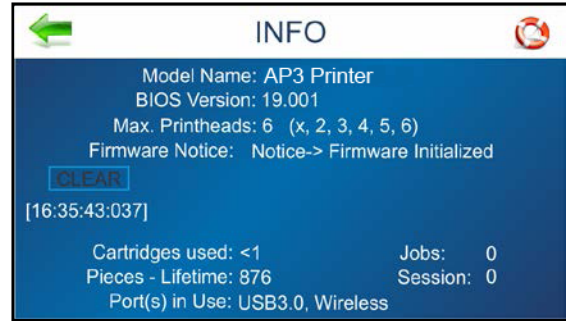

## PRINT IMAGE

Pressing the **Print Image** icon on the **Main Menu** opens the **Print Image** screen. Used to Select, Import or Delete an image. Imported images are stored within printer. You can then Print image or Merge image with next job.

**File Info:** Displays current jobs/images in the **Image Library** including printing parameters. Use the arrows to scroll through and select images from the **Printer Image Library**. Press the white button to display up to four current images simultaneously.

**Import:** Puts the Printer in mode to accept and store an image. Send image to printer. Image will be stored the **Printer Image Library**.

**Print:** Opens the **Print Setup** screen (*see next page*).

**Delete:** Deletes the image from the Printer Image Library.



## PRINT IMAGE – FULL SCREEN PREVIEW

Tap or press the image on the **Print Image**, **Print Data** or **Reprint** screens [A]. Image will fill the Touchscreen for easier viewing [B]. Tap image again to return to normal screen view.

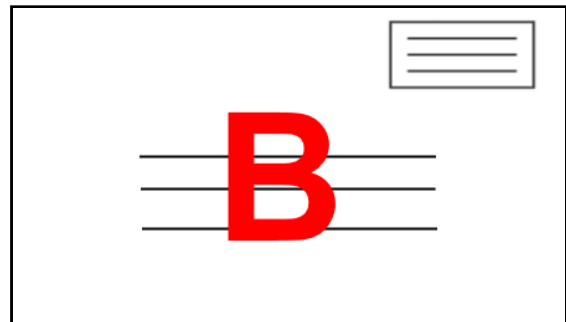

## PRINT IMAGE – IMPORT

Printer is ready to save a new image sent from computer. Send the image from your computer to the Printer as a single-page job.

Image will be saved with current printing parameters (*Page Size, Print Quality*).

**NOTE:** If you plan to Merge the Image with a Job, you must match Page Size and Layout of Merged Image and Job. In addition, send Merge Image at 600DPI.



## SECTION 3 OPERATING PRINTER

### PRINT IMAGE – DELETE

Job or image is being permanently deleted from the **Print Image Library**.



### PRINT IMAGE – SET-UP

Pressing the **Print** icon on the **Print Image** screen opens the **Print Image Set-up** screen.

Once an Image is loaded, the image name and dpi it was sent at are displayed at the top of the screen.

**Counter:** Enter the number of copies to be printed. Printer counts down from the number set on the screen. **Reset** button (*inside Counter box*) resets Counter to **1**.

**Print Quality:** Shows **Speed** in inches per second (*ips*) and **Print Quality** (*dpi*) set for the print job.

**NOTE:** Print Quality is determined by the **Print Resolution** set in the image or print job.

**Speed:** Shows the speeds available (**1=Slowest**; **4=Fastest**) for a particular job.

**NOTE:** Speeds available are determined by the Print Resolution/Print Quality set in the Image that was selected.

**Print:** Press to print the selected Image.

**Merge:** Press to Merge selected Image with the next Job that is sent to the printer.

The **Print Data** screen will open and the Merge Image indicator will turn green.

The **Print Data** screen allows you to Pause/Print/Cancel and monitor the status of the Job. See “Print Data” for details on how to use this screen.

#### Send the Job to the printer.

The Image you selected will be Merged and printed along with each record from the Job being printed.

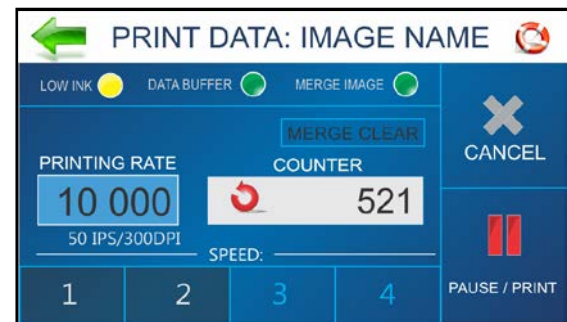

**NOTES:** To merge Image with a Job, the image must be saved at 600 dpi. New job must match Page Size and Layout of Merged Image. After job is complete, the Merge Image is deactivated.

## PRINTER SET-UP

Pressing **Printer Set-up** on the **Main Menu** opens the **Printer Set-up** screen. Features on this screen allow you to set Printer parameters to adjust the Printer to suit your needs.

**Ink Type:** Displays the Ink Types loaded in the Ink Cartridge Holders. Only authorized Ink Cartridges will display. Selecting an Ink Type allows editing options to be available.

**Printer Preferences:** Select from a list of Printer actions and/or set a **Feeder Stop** and **Conveyor Gap**.

**Language:** Select the language the Printer Touchscreen will display.

**Horizontal Alignment:** Fine-tune the spacing of the Printheads (1-6) in relation to each other horizontally (*side-to-side*).

**Vertical Alignment:** Fine-tune the spacing of the Printheads (2-6) in relation to each other vertically (*front-to-rear*).

**Factory Default:** Returns the Printer Setup to factory default settings.

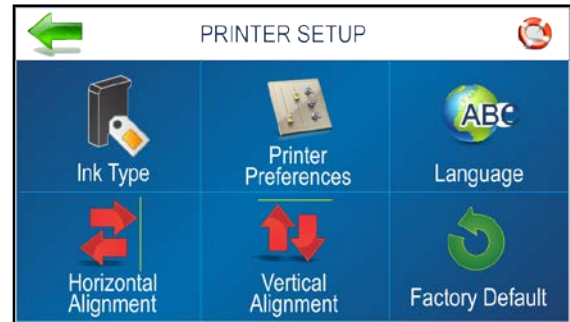

## INK TYPE

**Functions found on this screen:**

**Select Ink Type:** Select the recognized Ink Cartridge installed in a particular Cartridge Holder [1-6]. Tap the entry to select the Ink Cartridge. Tap the **Edit** box to open the **Ink Specifications** screen.

**NOTE:** Only authorized Ink Cartridges will be recognized by the Printer. An empty cartridge holder or invalid or unprogrammed Ink Cartridge will display as “-----”. An Ink Cartridge that is programmed, but not recognized by this Printer displays as “???????”.

**Ink Type Specifications (Paper/Pencil icon):** Displays the Ink Type and Boost entry box. Tap the **Boost** entry box to increase voltage for that Ink Cartridge up to the maximum recommended (*see below*).

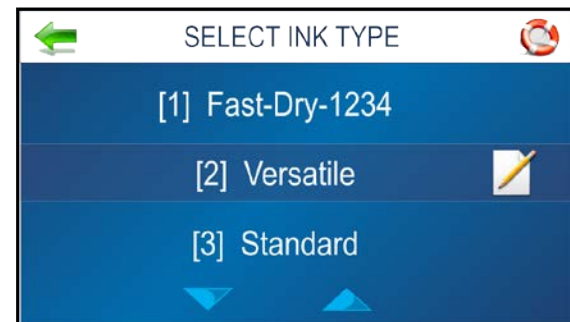

## EDIT INK TYPE

Boost the voltage on a particular ink cartridge to improve print performance under certain conditions. Once entered, the Printer memory will recall this information even if the Cartridge is removed and reinstalled in this Printer later.

### CAUTION

**Boosting the voltage above the maximum shown will damage the Ink Cartridge, Cartridge Holder and Printer.**

Press the **Boost** entry box to open the **Numeric Keyboard** to increase the voltage on a particular Ink Cartridge. **DO NOT increase the voltage more than the maximum listed on the touchscreen.**

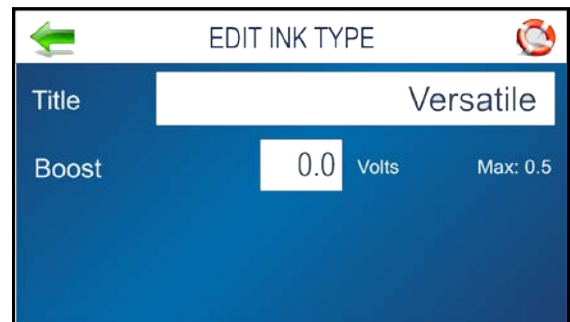

## SECTION 3 OPERATING PRINTER

### PRINTER PREFERENCES

This menu is also available by pressing **Quick Menu** key on the Control Panel. Note that **Tray Break** also has an **Edit** icon. Tap or press the icon to open the **Edit** screen. Press **MORE...** to go to next screen. Press **...BACK** to return to the previous screen.

**Purge First Piece:** Turning this feature ON causes the Printer to print one purge pattern on the first piece. After purge is completed, the next piece will be the first record of your database. Once this feature is selected, it remains ON, even if Printer is turned OFF.

**Select** = Purge First Piece ON.

**Deselect** = Purge First Piece OFF.

**Automatic Feed Start:** Turning the feature ON causes Printer to start feeding once the job is sent. Printer will come **Online**, the Printer starts feeding and printing automatically. Turn this feature OFF to use the **Print**

button on Touchscreen (or **Feeder ON/OFF** on Control Panel) to start printing. Turning the Printer ON or OFF does not affect your selection.

**Select** = Auto Feed Start ON.

**Deselect** = Auto Feed Start OFF.

**Keep Nozzles Alive:** Helps to prevent unused Printhead nozzles from becoming dehydrated during a printing job by spitting nozzles with set frequency.

**Select** = Keep Nozzles Alive ON (spitting occurs).

**Deselect** = Keep Nozzles Alive OFF (no spitting).

**Edit box:** Set the spitting frequency: **1x**, **2x**, **4x** (default), and **8x**.

Selecting **600 dpi Test** spits through all the nozzles at once. (*Example: This might be used to find a problem with the Printhead nozzles or to clear the printhead after sitting idle for long periods of time.*)

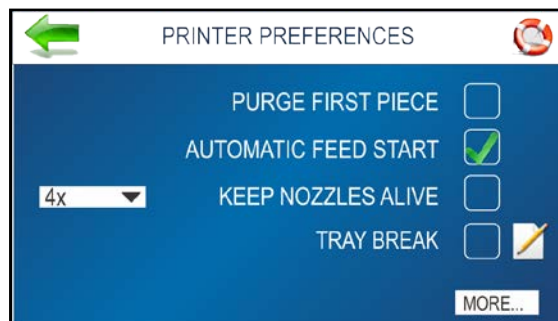
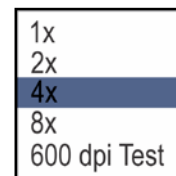

**Tray Break:** Set how you want printer to react when it receives a Tray Break command from the software application. **Select** “Tray Break” to use this feature.

**Edit box** = Select and set the **Feeder Stop** (number of seconds feeder should pause) or Select the **Conveyor Gap** (AP4 only).

**Feeder Stop:** Select and set the countdown timer to pause/stop the feeder, for x number of seconds, when the printer receives a Tray Break command.

Enter time in seconds (1-60).

**Conveyor Gap (AP4):** Used when AP4 Printer is set up in line with other mailing equipment (conveyors, tabbers, etc.) When this feature is activated, Printer responds to the Tray Break command by sending a signal to the conveyor to speed-up momentarily. This creates an obvious gap between end of one set of pieces and beginning of the next.

Enter the distance between the Media Sensor and the Conveyor. The Printer sends a delayed signal to the conveyor, based on the distance value set for “Conveyor Gap”, and continues to print/feed.





**Continuous Batch Counter:** Allows operator to select if they want the counter, on the Print Data screen, to automatically reset to zero with each new job that is sent or not (add job counts together).

**Unchecked** = Batch Counter resets before each job.

**Checked** = Batch Counter will not reset before each job.

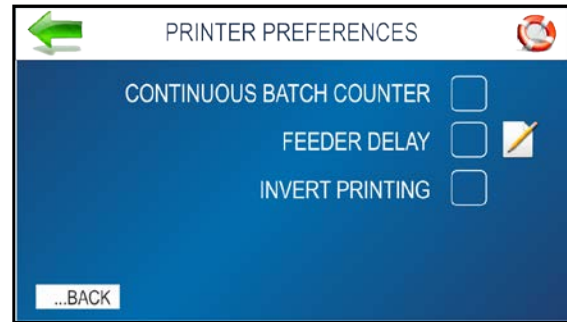

**Feeder Delay:** Used to lengthen the time between pieces being printed and ejected from printer. (*Example: Printing multiple copies of a stored Print Image that requires longer drying time before next piece drops onto previous piece.*)

**NOTE:** This feature applies only to internal Test Prints and Print Images within the Printer such as Test Print, Purge Print and Print Image stored in the Printer Image Library. When printing a Job from your software application, use the Printer Drivers “Feed Delay” feature.

**Unchecked** = No Feeder Delay.

**Checked** = Feeder Delay activated.

**Edit Box:** Set the amount of time the Feeder will pause in tenths of a second when printing internal Test Prints and Print Images.

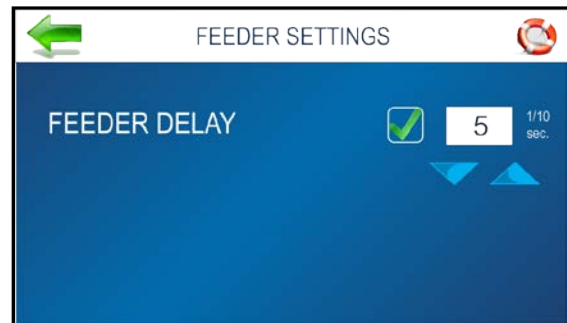

**Invert Printing:** Use to invert printing 180 degrees (normal/reverse).

**Unchecked** = Prints job normally.

**Checked** = Prints job inverted (*turned 180 degrees*).

**NOTE:** This feature applies only to internal Test Prints and Print Images within the Printer such as Test Print, Purge Print and Print Image stored in the Printer Image Library. When printing a Job from your software application, use the Printer Drivers “Normal Printing/Invert Printing” selections.

## SECTION 3 OPERATING PRINTER

---

### SELECT LANGUAGE

Select the language that the Printer Touchscreen will display.



### FACTORY DEFAULT

Restores most adjustments and settings to factory settings.



### HORIZONTAL ALIGNMENT

Adjusts offsets of individual Printheads (ink cartridges) to fine tune horizontal positioning of the printout. By doing this the operator can improve the alignment of images that are split between adjacent Printheads.

**Tip:** Horizontal print alignment will never be perfect from media leading edge to trailing edge. Alignment characteristics will vary from piece to piece and application to application. Therefore, if possible, it is suggested to position data to avoid splitting text/images between adjacent Printheads.

**Horizontal Alignment** is also accessible by pressing the **Quick Menu** key on the Control Panel.

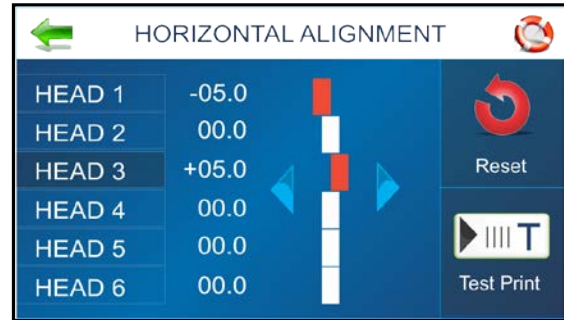

**Heads (1-6):** Align individual Printheads (*side-to-side*) up to  $\pm 100.0$  microns in 5.0 micron increments.

**To use:** Select the desired Printhead. Move the bar in the desired direction by pressing the directional arrows.

**Reset:** Horizontal alignment resets to **00.0** (*default*).

**Test Print:** Prints a test page using current adjustments and print parameters to check printing quality and Printhead alignment.

### VERTICAL ALIGNMENT

By design, the Printhead (ink cartridges), within a Print Unit, are purposely overlapping by a few nozzles. This feature allows the operator to control how many of the top nozzles, for each printhead, are enabled or disabled; in order to remove any overlap or gap, in the printout, between adjacent Printheads.

**Vertical Alignment** is also accessible by pressing the **Quick Menu** key on the Control Panel.



**Heads (2-6):** Adjust individual Printheads up to  $\pm 1.0$  microns in 0.1 micron increments.

**To use:** Select the desired Printhead. Move the bar in the desired direction by pressing the directional arrows.

**Reset:** Vertical alignment resets to **0.0** (*default*).

**Test Print:** Prints a test page using current adjustments and print parameters to check printing quality and Printhead alignment.

## **PRINTER TOOLS**

Press **Tools** icon on **Main Menu** to open the **Tools** screen.

**Estimator:** Select to set up an **Ink Cost Estimate** for a particular print job. The Printer runs, but does not print a preset sample number of pages (*up to 50 pages*) of the job to be printed. (*Set the number of pages in the Print Driver.*) The **Estimator** then determines the estimated ink cost for the entire print job.

See “Estimator” on following page for details.

**Ink Status:** Select to view the percentage of ink left in the ink cartridges and the estimated number of prints remaining for each cartridge at a selected resolution, based on the last page printed.

See “Ink Status” on following page for details.

**Diagnostic:** Select to run diagnostic tests on key Printer systems and components. You may be asked to run these tests and provide results when working with a technical support person.

See “Diagnostic” on following page for details.

**Network:** Set up access to a network. Also set up **Wi-Fi** capability for wireless access to a network.

**Wireless Status** displays network information about the Wi-Fi connection.

See “Network” on following page for more details.

**Screen Calibration:** Set the touch pressure (*touch sensitivity*) desired to activate the Touchscreen.

See “Screen Calibraion” on following page for more details.

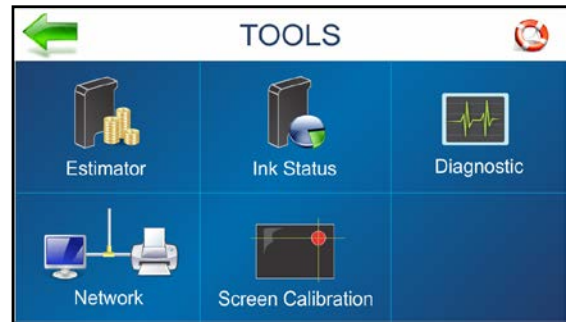

### INK ESTIMATOR

This tool estimates the cost of ink for a particular print job. The Printer runs and simulates printing a preset number of pages. Set the job to print 1-49 pages (*in the Print Driver*) for the printer to make the estimate. Generally, the higher the number of pages sent, the more accurate the estimate.

**NOTE:** It is recommended that **Purge First Piece** be turned off. This will use much less ink and increase the accuracy of the estimate.

**Ink Cartridge Cost:** Tap/press the entry box to enter the cost of the ink cartridges.

**Number of Pages:** Tap the entry box to enter the total number of pages for a given job.

**Start Estimation Mode:** Tap or press to start the Ink Estimator.

**Estimated Ink Cost:** Displays the estimated ink cost for the entire print job.

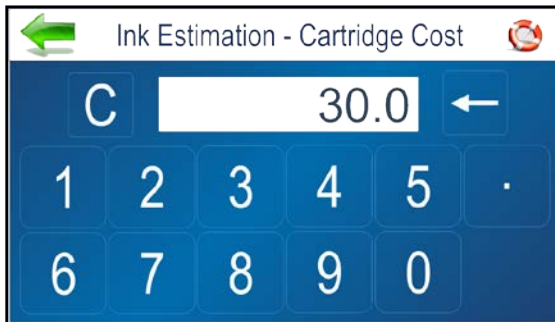

### INK STATUS

Shows the percentage of ink remaining in each Ink Cartridge and the estimated number of prints remaining at a selected resolution. (*Resolution is selectable.*)

**NOTE: Estimation is based on the last page printed.**

“-----” Indicates no Ink Cartridge present or an unrecognized, unprogrammed Ink Cartridge.

“??????” Indicates an Ink Cartridge not programmed for this Printer.

**Ink Status** is also accessible by pressing the **Quick Menu** key on the Control Panel.

A screenshot of the 'EASYInk Coated INK STATUS' screen. It displays a table with the following data:

HEAD#	%	LIFE	
[1]	EasyInk Coated	100	10 000
[2]			
[3]	EasyInk Coated	100	10 000
[4]			
[5]	EasyInk Coated	100	10 000
[6]	EasyInk Coated	100	10 000

Large numbers (150, 200, 300, 600) are displayed on the right side of the screen, corresponding to the rows.

## SECTION 3 OPERATING PRINTER

### DIAGNOSTICS

Runs tests on Printer components and systems listed on the screen at variable speed.

**To run Test:** Remove media from the Printer. Press **Start Test** to start the diagnostic cycle. Press again to stop. While **Test** is activated, run one piece of media through the Printer to test the Sensor function. The **Test** cycles through each component automatically. Green lights indicate component is functioning properly.

**NOTE:** After running one piece, verify that the piece length was measured accurately. If the piece fed through, but no piece length was displayed and the Sensor condition still shows red; stop this test, Shutdown and Power OFF the Printer and clean the Media Sensor.

If the piece measured longer than the actual piece length; the piece is probably slipping or hesitating as it feeds. In this case, check or adjust the Sheet Separators and check and adjust the Media Thickness setting.

**Clutch w/Sensor: Unchecked box:** Tests clutch function (on/off) using an automated routine.

**Checked box:** With media loaded, tests Clutch and Media Sensor function.

**Conveyor (AP4 Only):** Checking/unchecking the box turns the “conveyor speed-up” relay on and off. (*Listen for relay clicking.*)

**Feeder (AP4 Only):** Checking/unchecking the box turns the “external feeder” relay on and off. (*Listen for relay clicking.*)



### NETWORK SET-UP

Press the **Network** icon on the **Tools** screen to open the **Network Settings** screen. Select **Network Setup** to enter the settings for connecting the Printer to your network. Enter the Printer Name, IP address, Subnet address, Gateway address, DNS #1 and DNS #2 and select or deselect DHCP as needed. **Refresh** refreshes/updates the network connection.

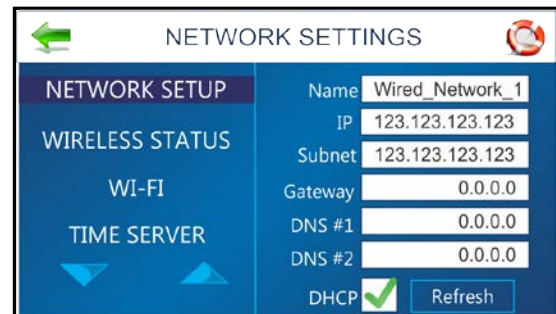

### WIRELESS STATUS

Once the **Network** and **Wi-Fi** are set up, this screen displays information about the wireless network connection.

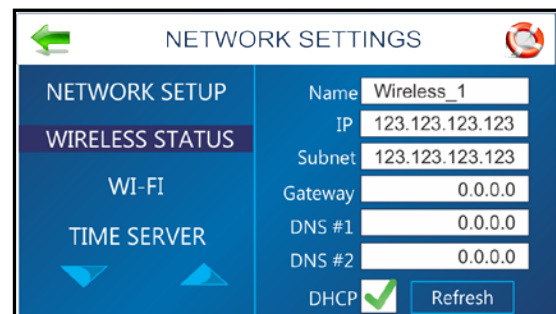

## WI-FI SET-UP

Press the **Network** icon on the **Tools** screen to open the **Network Settings** screen. Make sure the Wi-Fi antenna (*included*) is connected to the Printer's Wi-Fi port.

1. Select **WI-FI**.
2. Select the desired Network from the list of **Wi-Fi Networks**.
3. Enter **User ID** and **Password**. Click **OK**.
4. Screen will show if you are connected to the Network. If connection fails, try again. Check that you are connecting to the correct Network. Check User ID and Password.
5. Click **Disconnect** to end connection.

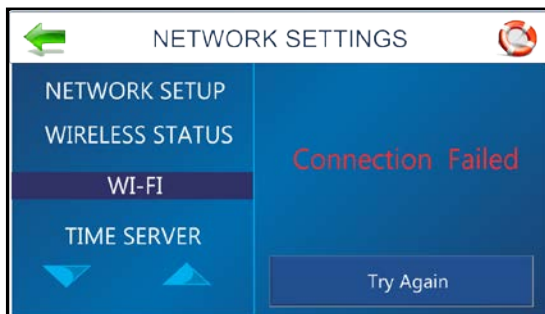

## TIME SERVER (DATE AND TIME)

Displays the IP address of the Time Server being used and/or the Time Server's network name.

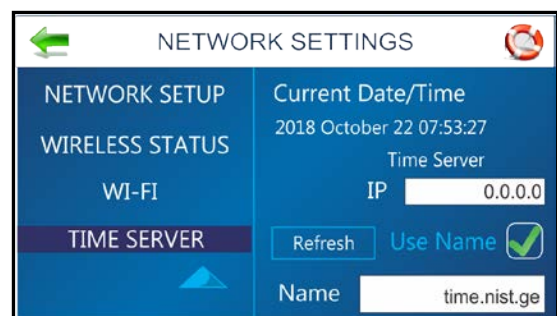

## SECTION 3 OPERATING PRINTER

### TOUCHSCREEN CALIBRATION

Adjust the touch pressure (*sensitivity*) needed to activate functions on the Touchscreen. (*Lower percentage = less pressure, more sensitive. Higher percentage = more pressure, less sensitive.*) Follow instructions on the screen to perform the calibration. **Time Remaining** counts down the 15 seconds given to complete each step. A screen message informs you if the calibration succeeded or failed.

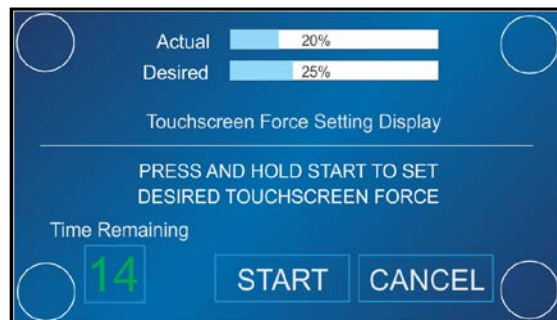

### *Shutdown/Reset Button*

When the **Shutdown/Reset Button** on the Control Panel is pressed, the **Shutdown Printer** screen opens.

#### Functions found on this screen:

**Reset:** Stops and restarts the Printer's software and electronics.

**Shutdown:** Safely shuts down software and powers off Printer. Once Printer shuts off you can safely turn the Main Power Switch OFF.

**USB Disconnect:** Disconnects or reconnects Printer communication with the USB Port.

**Sleep Now:** Puts the Printer in Sleep Mode. Wakes when the Display Screen is touched or a job is sent to the Printer through the USB or network.

**Software Reload:** Similar to **Reset**, but safely shuts off and reloads the software without powering off the Printer's electronics.

**Port Reset:** Clears any jobs being sent to the Printer. **Example:** After a job is cancelled at the Printer, the remainder of the job may continue to be sent by the computer. This may cause the Printer to get "stuck" because it can no longer read the job. Press the **Port Reset** button to fully clear the job. **NOTE:** Usually once the **Shutdown/Reset Button** button on the Control Panel is pressed, this action happens automatically and the **Port Reset** button will be inactive. If the **Port Reset** button is still active, you can press it to clear the job.

**Cartridge Initialize:** Resets/reestablishes communication between the printhead cartridges and the Printer.

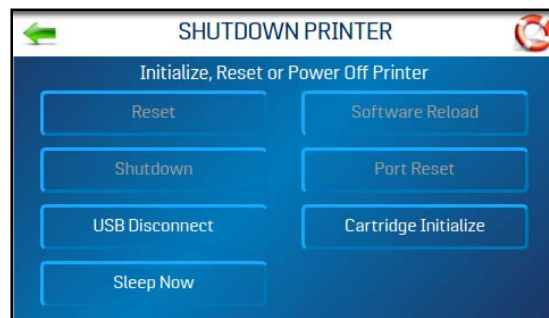

### *Transport/Pass-Through Button*

Pressing the **Transport** button on the Control Panel opens the **Transport ON/OFF Control** screen. Turning this feature on allows the Printers transport to operate without printing. This can be used for short duration to eject any media under the Printheads. It can also be used to operate the Printer in a continuous non-printing "pass-through" mode when the Printer is used in an in-line system, but is not needed for a particular job. Press the **RUN** button to start the Transport. Press **STOP** to stop the Transport.

**Adjust Printer Speed:** Generally, use the slowest speed (**1=Slowest**) to eject media. When operating the Printer as a "pass-through" device, tap one of the available speeds listed at the bottom of the screen (**1=Slowest; 4=Fastest**). **NOTE:** Ideally the Printer speed should be the same or slightly slower than the next machine in line.

Press the **Transport** button on the Control Panel to exit the **Transport Control** screen.





## *Firmware Updates*

### **To install a firmware update:**

Once a firmware update is sent to the Printer, the “**Firmware Updates**” screen appears when the **Shutdown/Reset Button** on the Control Panel is pressed. The screen indicates how many update files are available.

**NOTE:** If no firmware updates were sent to the Printer, the normal **Shutdown Printer** screen appears.

- Press “**Install Updates**” to load the new firmware.
- Press “**Postpone**” to install the firmware at a later time. **NOTE:** The **Firmware Updates** screen will appear each time the Control Panel **Shutdown/Reset Button** is pressed until the firmware update is installed.



## SECTION 3 OPERATING PRINTER

### Quick Menu

Allows quick access to often-used Printer functions without having to scroll through a number of screens. Open by pressing the **Quick Menu** key on the Control Panel. Press **Quick Menu** key again to exit the screen. (See individual explanations of screens in “Using the Touchscreen” section.)

**Test Feed/Reprint:** Default is **Test Feed**. If no data is present, this button allows you to test feed blank sheets of media. In case of a Printer jam or double feed, the **Test Feed** button becomes **Reprint**. Recover missed or misprinted pieces by pressing **Reprint**. Use the arrows to go back to the initial misprinted piece (or further back if desired) to start reprinting. Press **Print** to start printing.

**Purge Print:** Prints an ink pattern at 600 dpi to clear all of the ink nozzles in all of the ink cartridges.

**Horizontal Alignment - Heads (1-6):** Adjust offset of individual Printheads (side-to-side) up to  $\pm 100.0$  microns in 5.0 micron increments.

**Vertical Alignment - Heads (2-6):** Disables top nozzles in individual Printheads to reduce nozzle overlap. Adjust up to  $\pm 1.0$  microns in 0.1 micron increments.

**Printer Preferences:** Select and set various Printer features including **Purge First Piece**, **Automatic Feed Start**, **Keep Nozzle Alive**, **Tray Break**, **Continuous Batch Counter**, **Feeder Delay** and **Invert Printing**.

**Ink Status:** Shows the percentage of ink remaining in each Ink Cartridge and the estimated number of prints remaining at a selected resolution.

**Resolution** is selectable.

EASYInk Coated		INK STATUS		
HEAD#		%	LIFE	
[1]	EasyInk Coated	100	10 000	150
[2]				200
[3]	EasyInk Coated	100	10 000	300
[4]				600
[5]	EasyInk Coated	100	10 000	
[6]	EasyInk Coated	100	10 000	

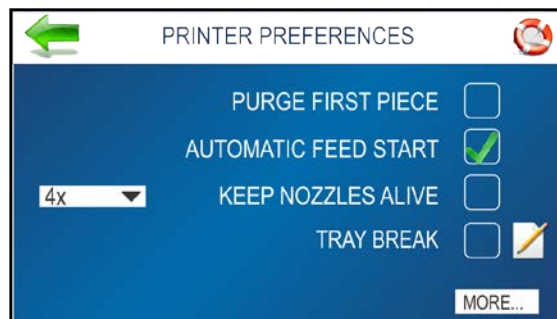
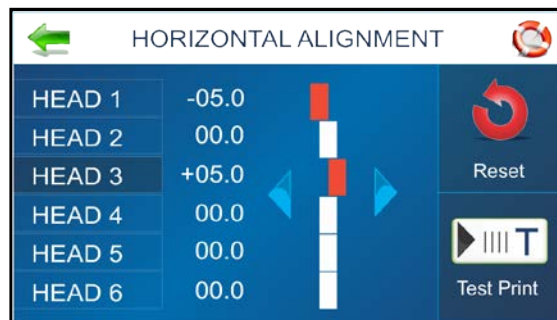
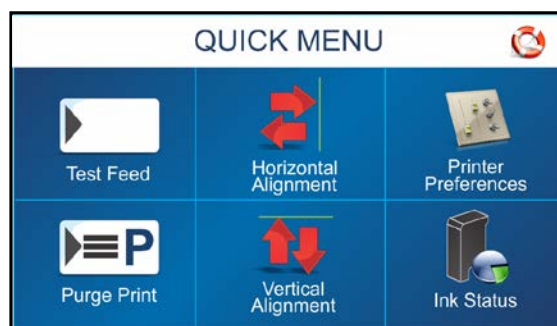

## Printer Driver Properties

**Printer Driver** describes to Printer how to print your job. It controls Printer operation and allows you to send fixed and variable text and graphics to Printer. Within your software application is a **“Print”** function. In that **“Print”** function is a **Properties** button. Through **Properties** you can control the Printer’s output. Use the **Properties Windows** to customize Printer’s output.

To start printing, click **File**, then **Print**. **“Print”** window opens. To print the job, click **Print**.

To use the special features built into Printer Drivers, click **“Printer Properties”** to open the **Document Properties Window**.

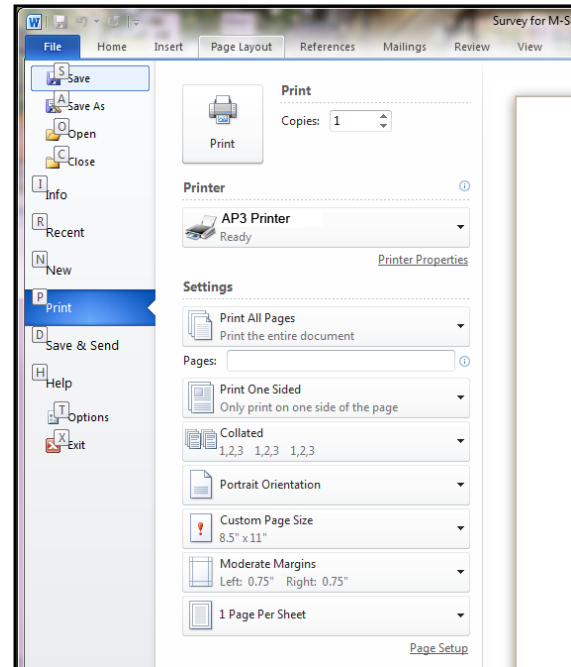

Layout window opens.

**Layout Tab** lets you select **Portrait** or **Landscape** orientation.

**NOTE: Orientation** should always be set to **“Portrait”**.

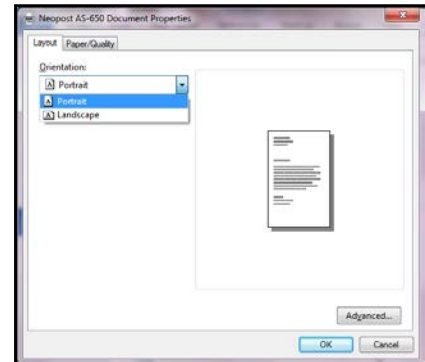

**Paper/Quality Tab** contains one element, Paper Source, that is used to reverse or invert printing on Printer.

**Paper Source** permits you to reverse the printing direction 180 degrees. Select **Normal Printing** or **Invert Printing**.

**NOTE:** If you choose **Automatically Select** “Normal”, orientation is used.

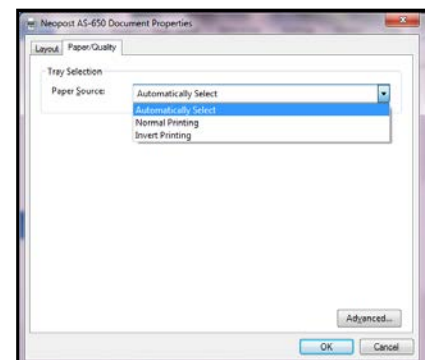

## SECTION 3 OPERATING PRINTER

Clicking **Advanced** opens “**Advanced Options**” window.

When **Advanced Options** window opens, there are **Paper/Output** and **Document Options** to set up, change, and adjust Printer.

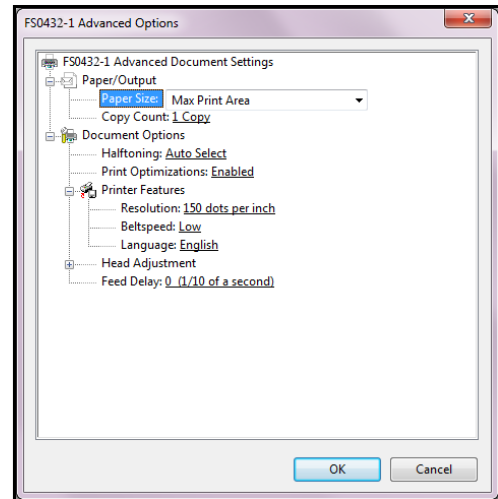

### Paper/Output

**Paper Size:** Lets you select the size of media to be used.

**Copy Count:** This feature is currently disabled.

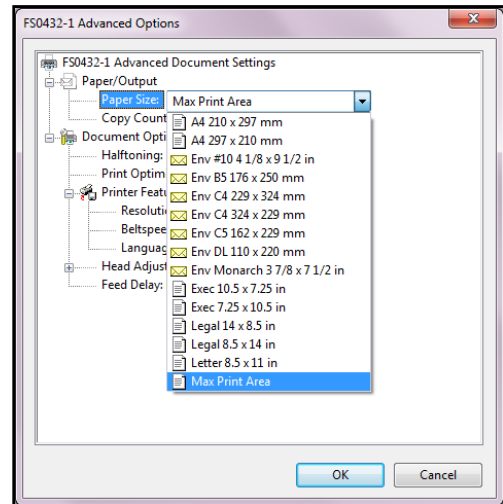

### Document Options

**Document Options** is used to set half-toning options, and enable Print Optimizations. In **Printer Features** you can set the resolution of Printer, set Printer speed, set the language the Printer operates in, and add a delay to the feed to provide separation between pieces.

**Resolution:** Sets **resolution** of print quality. Changing **resolution** to a higher number (*e.g. 200 DPI to 600 DPI*) increases image quality. **NOTE: Higher resolutions reduce print speed options.**

AP3 Printer	
Resolution	Speeds Available
600 x 150 DPI	Low, Medium, Medium High, High
600 x 200 DPI	Low, Medium and Medium High
600 x 300 DPI	Low and Medium
600 x 600 DPI	Low

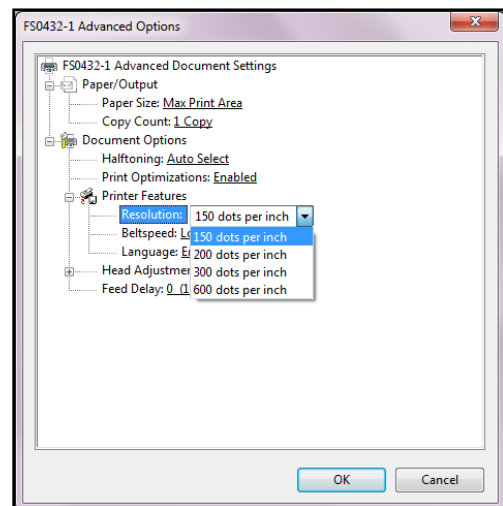

**Belt Speed:** Sets **Print Speed** for a print job. The speeds available for a particular job are determined by the **Resolution** set for the job.

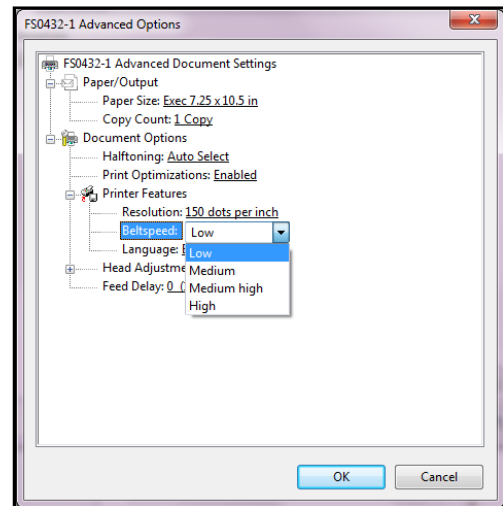

**Language:** Choose the language the Printer will operate in and display.

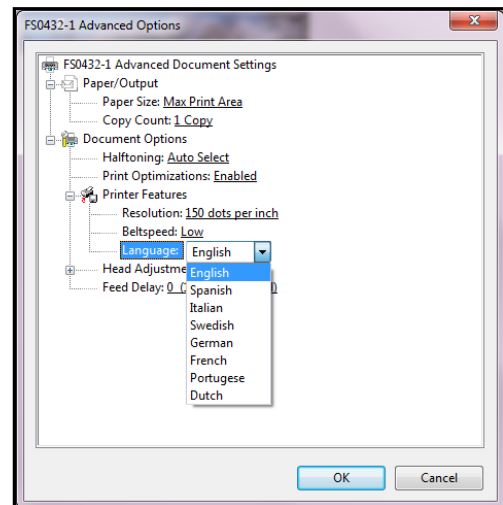

## SECTION 3 OPERATING PRINTER

---

### Head Adjustment

This feature is disabled in the driver.

Use the Printers Quick Menu, “Horizontal Alignment” feature to adjust alignment.

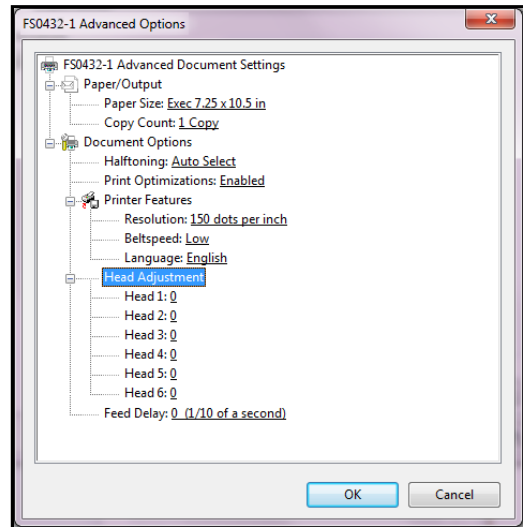

### Feed Delay

**Feed Delay** can be used to put more space between pieces as they are printed. This gives first piece printed more time to dry before next piece is printed.

**Adjustment is made in 0.1-second increments.**

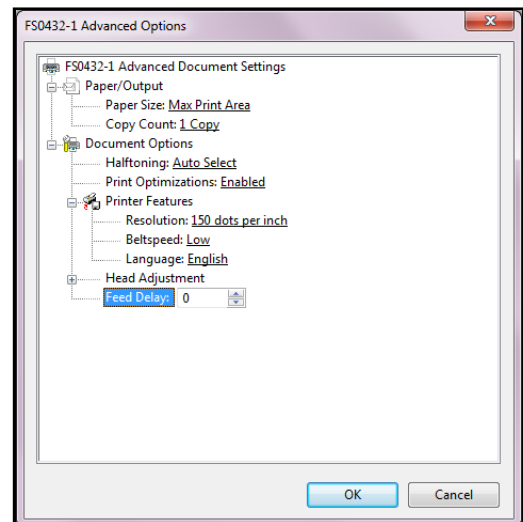

## SECTION 4 - *Maintenance*

This section covers how to care for Ink Cartridges, clear paper jams, replace Sheet Separators, and perform routine maintenance on Printer.

### *Inkjet Cartridge*

Inkjet Cartridges must be replaced when out of ink, when print quality is poor, or when purging and cleaning have not helped the image quality. Approximate life of HP 45 Inkjet cartridges, based on three lines of 20 characters at 10-point size per address, is:

<b>600 x 600 DPI</b>	<b>50,000 addresses</b>
<b>300 x 600 DPI</b>	<b>100,000 addresses</b>
<b>200 x 600 DPI</b>	<b>150,000 addresses</b>
<b>150 x 600 DPI</b>	<b>200,000 addresses</b>

**NOTE:** These figures can vary depending on font selected.

#### CAUTION

**For continued protection against possible fire, use only authorized Ink Cartridges. 40mL max ink for each cartridge. Flashpoint shall be > 93.3C per Material Safety Data Sheet.**

### Replace Inkjet Cartridge:

1. Open Latch Lever to remove used Cartridge from Cartridge Holder. Pull Cartridge up and out of Holder.
2. Remove new Inkjet Cartridge from packaging. Take care not to touch copper contacts, metal plate, or gold printhead. Remove protective tape or clip from Printhead.
3. With Cartridge's Printhead pointing down, slide Cartridge into Holder. Push down and toward contacts in Holder.
4. Make sure Cartridge is seated in Holder. Close Latch Lever to secure Cartridge. **DO NOT** force Latch Lever into place.
5. Repeat **Steps 1-4** for remaining Cartridges.

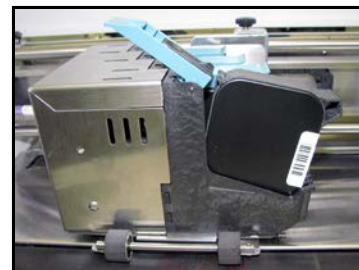

#### CAUTION

**Never shake, drop or hit Cartridge against the palm of your hand or any other hard surface. Shaking the Print Cartridge does not "mix" ink and hitting Cartridge against a hard surface does not clear Nozzles.**

**These actions hurt print quality because they allow bubbles to form near the ink firing chambers. These bubbles prevent the nozzles from firing, causing white streaks in print image.**

## **Inkjet Cartridge Storage**

**Short-term Cartridge Storage** (Less than 8 hours or less than 2 hours in hot/dry environments.)

- The cartridge can be left in the Printer, for short periods of time.
- The next time that the Printer is used, the cartridge nozzles may have to be cleaned and purged

**Long-term Cartridge Storage** (More than 8 hours or more than 2 hours in hot/dry environments.)

- Clean the cartridge and place the cartridges in a re-sealable container (i.e. Tupperware) with a damp sponge or towel to maintain humidity and prevent the cartridge from drying out.  
Note: Do not allow the nozzle plate to make contact with the sponge/towel, or the ink will be wicked from the cartridge.
- When the cartridges are ready to be used again, the cartridge body and contact area will need to be dried and the nozzles will need to be cleaned and purged.

**CAUTION!** Be sure the contact area of the cartridge is dry, before installing it into the printer or damage to printer's electronics will result.

**Note:** Decap Time (time it takes for unsealed cartridge nozzles to become clogged) will vary greatly. Ink type, environment, prior cartridge maintenance, and cartridge condition can affect decap time.

## **Disposal**

Cartridges may be disposed of in a safe manner in accordance with local/national regulations.

In case of an ink spill, use soap and water to clean up any problem areas.  
Abrasive soap usually removes ink from hands.

	<b>Ink in cartridge may be harmful if swallowed. Keep new and used cartridges out of reach of children. Discard empty cartridges immediately.</b>
---	---

## **Cleaning Printhead**

Maintain good print quality by keeping Printheads clean. During printing process ink spray, paper fibers, and dust can build up on Printheads. This build-up eventually degrades print quality. If you notice problems with print quality, or to just prevent a build-up from occurring, wipe Printhead with a wet lint-free cloth.

<b><i>Cloth should be:</i></b>	<b><i>Cloth should not be:</i></b>
✓ Soft	✗ Abrasive
✓ Lint-Free (Fiberless)	✗ Made of small fibers
✓ Moistened with water ( <i>Distilled is best but tap water will work</i> )	✗ Dry or contain chemical additives

Wipe slowly across the long-axis with Printhead facing down (*as shown*). **DO NOT** apply excessive force, as this could scratch Nozzle area.





### ***Purging Nozzles***

If the Printhead sits inactive for a time, ink may dry in the nozzles. Printing may not remove these “ink plugs” from the nozzles. White streaks will show up in the printed text or graphic. In order to obtain better print quality, these ink plugs need to be forced out or purged. A **Purge Print** routine is built into Printer. Access this feature by using the **Quick Menu** key on the Control Panel.

1. Wipe Printhead with a wet cloth as described in “*Cleaning Printhead*” on previous page.
2. With media loaded in the Feeder, press the **Quick Menu** key, then “**Purge Print**” icon. Press “**Print**” to activate the purge. Purge prints an ink pattern at 600 dpi to clear all of the nozzles in all of the ink cartridges. **Repeat if necessary.**
3. Wipe Printhead again with a moist cloth.

**NOTE: For more information, see Troubleshooting Printheads in Section 5 – Troubleshooting.**

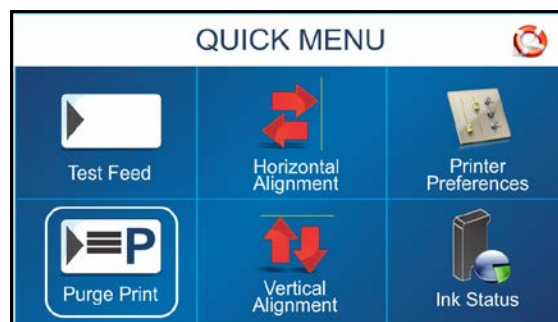

### ***Jams in Printer***

If a jam occurs, **STOP the Printer**. Recover missed addresses using the **Quick Menu** key on the Control Panel, then pressing “**Reprint**”.

**Some possible reasons for jamming are:**

1. Feeding more than one piece of media.
2. Damaged media, such as dog-eared (*turned down corners*).
3. Media that is not stiff enough may not be usable. Media that meets Postal stiffness requirements for automated feeding is acceptable in the Printer.
4. Envelopes caught under the flap of another envelope or stuck to one another may cause jamming.

### **Removing Jammed Media**

1. It may be necessary to move one or more Printheads to gain access to jammed media. Take care when removing jammed media to avoid damaging Printheads. All pieces of jammed media must be removed from the feed path.
2. Follow instructions, *Section 3 – Operating Printer, Quick Menu, “Reprint”*.

### ***Replace Sheet Separators***

Sheet Separators insure separation of pieces as they are being fed. They wear and must be replaced periodically. If you experience double sheet feeding and cannot adjust the Separators to prevent it, they should be replaced.

1. Turn OFF and unplug Printer.
2. Release Separator Locking Lever and move Media Side Guides to their maximum open position.
3. Lower Separators so they touch Feed Roller.
4. Remove screw [A] and Separator Support [B]. Then remove Separator [C] by prying it out of Holder.
5. Install a new Separator and reinstall Separator Support and screw.

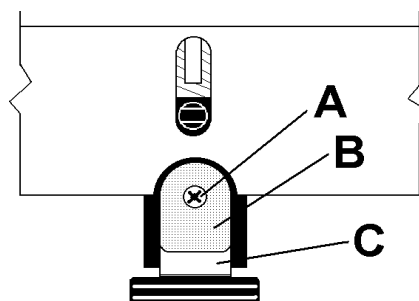

## Cleaning

### WARNING!

**PRINTER IS A PRECISION MACHINE THAT SHOULD BE CLEANED REGULARLY TO INSURE MANY YEARS OF SERVICE. BEFORE PERFORMING ANY MAINTENANCE, DISCONNECT PRINTER FROM ITS POWER SOURCE!**

Printer must be cleaned regularly of accumulated paper dust and ink. Depending on types of media that are run, paper dust may accumulate within Printer and on Transport. To properly clean Printer, unplug it from power receptacle and remove covers.

- **Internal Areas:** Best cleaned using a vacuum with a soft brush attachment to help loosen dust particles. Take care not to damage PC Boards or electrical wiring.
- **Exterior Areas:** May be cleaned with any standard non-abrasive household cleaner that does not contain plastic-harming solvents.

### CAUTION

**NEVER SPRAY OR POUR CLEANERS DIRECTLY ON OR INTO THE PRINTER. EXCESS LIQUID COULD HARM ELECTRONIC PARTS. ALWAYS DAMPEN A RAG WITH THE CLEANER AND APPLY IT TO THE PARTS TO BE CLEANED.**

## Feed Rollers and Forwarding Rollers

Feed and Forwarding Rollers can become glazed with paper lint and ink from media. They should be regularly cleaned with a mild abrasive household cleaner on a damp cloth. Avoid using solvents on Rubber Rollers.

## Cleaning Media Sensor

Periodically check Media Sensor for dust and debris, (*located under Media Hold-down Wheel Assembly*).

1. Use the Media Thickness Knob to raise the Printhead Carriage Assembly to its highest setting.
2. Use canned or compressed air into the Media Sensor port [A] and under the Media Sensor Reflector [B] to remove dust and debris. **NOTE: If necessary, wipe the Reflector surface (under the mounting plate) with a clean, lint-free cloth.**

**CAUTION:** Compressed Air propellant can be flammable. Let printer sit to ventilate for a few minutes before reconnecting power cord and switching Main Power Switch ON.

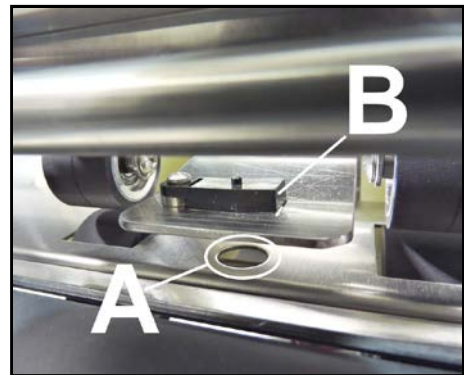

## Cleaning Touchscreen

Carefully clean the Touchscreen by wiping with a lint-free cloth and a non-abrasive cleaner made for touchscreens on computers and cell phones. **DO NOT spray cleaner directly on screen, spray on cloth, then clean screen.**



## SECTION 5 – *Troubleshooting Guide*

Troubleshooting Guides are provided to assist you in solving any problems that might occur with Printer or its software. We tried to make them as complete as possible. The best advice we can offer is to make sure that the system is setup properly, plugged in, has an adequate supply of ink before attempting to troubleshoot any problem.

**WARNING!**



**DO NOT REMOVE SIDE COVERS ON PRINTER!  
HIGH VOLTAGES PRESENT BEHIND COVERS!**

### *HP Inkjet Print Cartridges*

CONDITION	PROBLEM	SOLUTION
<b>Black streaks in text</b> <del>This is a sample of text showing black streaks in the copy.</del>	Lint or paper dust on Printhead.	Clean the Cartridge Nozzles with a clean lint-free cloth moistened with distilled water. Print a <b>Purge Print</b> . See “ <b>Section 4 – Maintenance,</b> ” <b>Purging Nozzles</b> .
<b>Cartridge will not print</b>	Media Feeds without printing, even though it traveled under cartridge(s).	Check to make sure protective tape is removed from Printhead. Remove and reinsert Ink Cartridge into Carriage Holder. Install new Print Cartridge. <b>Tip:</b> If it counts but doesn’t print Check/Clean Paper Sensor.
<b>White streaks in text or graphics</b> Smith Company 123 Main St. Anytown, USA 12345 1234	Clogged/Damaged Nozzle(s). Lint or dust blocking nozzles.  Poor contact between Printhead and Printhead Holder.	Clean the Cartridge Nozzles with a clean lint-free cloth moistened with distilled water. Print a <b>Purge Print</b> . See “ <b>Section 4 – Maintenance,</b> ” <b>Purging Nozzles</b> . Clean Interconnects. Remove and reinsert Ink Cartridge into Holder. Insert new Print Cartridge.

**SECTION 5  
TROUBLESHOOTING**

*Printer*

<b>CONDITION</b>	<b>PROBLEM</b>	<b>SOLUTION</b>
<b>Extra lines; losing data</b>	Database problem.	Check data in database program.
<b>Improper output (address information out of order, misfeeding, etc.)</b>	Wrong Interface settings. Static electricity. Dirty Media Sensor.	Check software or database on PC. Turn Printer OFF and ON. Clean Media Sensor.
	Paper jam.  Media is curled or bent. Media is too thin.  Sheet Separators need adjustment.	Clear media from feeder and/or print transport area. Uncurl media. <b>Minimum media thickness:</b> at least 0.008" (0.2 mm) thick. Adjust Sheet Separators. Check Media Thickness adjustment.
	Media sticking together or overlapping.	Clear media from feeder and/or print transport area. Check adjust Sheet Separators. Use <b>Reprint</b> (on <b>Quick Menu</b> screen) to retrieve/restore missing or misprinted pages in the print job.
<b>No communication</b>	Improper cabling / connector.  Unit not receiving power.	Use proper cable (see <i>Operator Manual</i> ). Check plug connections, ON/OFF Switch and Fuse on Back Panel (see <i>Operator Manual</i> ).
<b>Not printing on media</b>	Media not positioned properly. Media not running under printheads.	Adjust Printhead vertically. Adjust the margin setting in layout software.
<b>Print too light or missing character dots</b>	Clogged or dirty Printheads. Running out of ink.	Purge or clean Ink Cartridges. Replace Ink Cartridges.
<b>Blurry address</b>	Image is not sharp.	Install new Ink Cartridge. Media Thickness adjustment set too high. Adjust Printhead closer to the media.
<b>Split line of type</b> Smith Company 123 Main St. Anytown, USA 12345-1234	Line of type is placed across two Printheads.	Reposition text in layout so that it does not print across Printheads. Adjust positioning of Printheads in relation to each other using <b>Head Alignment</b> in <b>Quick Menu</b> on the Control Panel.
<b>Uneven split line of type</b> Smith Company 123 Main St. Anytown, USA 12345-1234	Some but not all of a line of type across two Printheads matches up.	Reposition text in layout so that it does not print across two Printheads. Check Sheet Separator adjustment. Separators should just touch media. Check Printhead height. Printhead set too high will cause media to slip as it passes under Heads.

## Touchscreen Messages

The Touchscreen will display messages to alert you to problems or to indicate a process is finished.

SCREEN MESSAGE	PROBLEM	SOLUTION
 <p>ERROR 01 <b>PAPER FEED</b> CLEAR THE PRINTZONE BEFORE CONTINUING WITH PRINTING OK</p>	<p>Paper jam.</p> <p>Media is curled or bent. Media is too thin.</p> <p>Sheet Separators or Media Thickness need adjustment.</p>	<p>Clear media from feeder and/or print transport area.</p> <p><b>Minimum media thickness:</b> at least 0.008" (0.2 mm) thick. Adjust Sheet Separators. Check adjust Media Thickness. Press <b>OK</b> to continue.</p>
 <p>ERROR 02 <b>DOUBLE FEED</b> INSPECT THE LAST PRINTED PIECE BEFORE CONTINUING WITH PRINTING OK</p>	<p>Media sticking together or overlapping.</p>	<p>Clear media from feeder and/or print transport area.</p> <p>Use <b>Reprint</b> (on <i>Quick Menu screen</i>) to retrieve/restore any missing or misprinted pages in the print job. Adjust Sheet Separators. Press <b>OK</b> to continue.</p>
 <p>ERROR 03 <b>FEEDER EMPTY</b> RELOAD MEDIA BEFORE CONTINUING WITH PRINTING OK</p>	<p>No media in Feeder/Hopper or hesitation in media feed.</p>	<p>Check adjust Sheet Separators, Side Guides and Rear Wedge.</p> <p>Reload media. Press <b>OK</b> to continue.</p>
 <p>ERROR 04 <b>TIME OUT</b> RESTART TRANSPORT BEFORE CONTINUING WITH PRINTING OK</p>	<p>Printer operation has timed out or Printer was paused too long.</p>	<p>Check Printer. Press <b>OK</b> to continue.</p>
 <p>ERROR 05 <b>NO ENCODER SIGNAL</b> PAPER TRANSPORT NOT DETECTED. CHECK FOR JAMMED/STALLED TRANSPORT. CALL SERVICE. OK</p>	<p>Printer Motor has stopped.</p> <p>Wire Harness connection is loose or broken.</p> <p>Encoder Belt worn or broken.</p> <p>Encoder Sensor not working.</p>	<p>Check Printer Motor.</p> <p>Check <b>J5</b> connector on I/O Board.</p> <p>Check Encoder Belt.</p> <p>Check Encoder Sensor.</p>
 <p>ERROR 06 <b>STOP TIME OUT</b> RESTART TRANSPORT BEFORE CONTINUING WITH PRINTING OK</p>	<p>Printer Transport was left running and automatic 5-minute timeout has started.</p>	<p>Press <b>OK</b> to restart transport before continuing to print.</p>

## APPENDIX A – Specifications

<b>PRINT TECHNOLOGY</b>	6-Head Inkjet, proprietary HP-45 High Capacity Inkjet Cartridges
<b>ADDRESS SPEED</b>	Up to 30,000/hour (#10 Envelopes)
<b>PRINT QUALITY/SPEED</b> (Dots Per Inch)	<b>1-High Quality</b> 600 x 600 DPI (25 in./sec.; 125 ft./min.; 38 m/min.) <b>2-Standard Quality</b> 600 x 300 DPI (50 in./sec.; 250 ft./min.; 76 m/min.) <b>3-Letter Quality</b> 600 x 200 DPI (75 in./sec.; 375 ft./min.; 114 m/min.) <b>4-Draft Quality</b> 600 x 150 DPI (100 in./sec.; 500 ft./min.; 152 m/min.)
<b>IMAGE AREA</b>	3" x 15" (76.2 mm x 381 mm)
<b>PRINT ORIENTATION</b>	Right-to-Left
<b>INK MONITOR</b>	Visible on Display
<b>FONTS</b>	All TrueType fonts available on PC
<b>PRINTS</b>	Prints graphics, logos, and barcodes
<b>MATERIAL SIZE</b> (Minimum to Maximum)	<b>Length:</b> 5" to 15" (127 mm x 381 mm) <b>Width:</b> 2.75" to 10" (69.9 mm x 254 mm)
<b>MATERIAL THICKNESS</b>	<b>Minimum:</b> 0.008" (0.2 mm) <b>Maximum:</b> 0.375" (9 mm)
<b>FEEDER CAPACITY</b>	Up to 750 #10 envelopes
<b>PROCESSOR</b>	600 Mhz Dual-core ARM Cortex-A9 MP Core
<b>MEMORY</b>	1 GB of DDR3-1600Mhz SDRAM 8 GB ( <i>default</i> ) microSD. Not externally accessible
<b>PRINT COLORS</b>	Proprietary water-based inks in HP 45 Inkjet Cartridges
<b>INK</b>	Water-based, may require drying assistance for coated stock
<b>SOFTWARE</b>	Windows™ compatible Printer Drivers for Windows™ operating systems
<b>DIAGNOSTICS</b>	Resident in firmware
<b>FIRMWARE UPDATE</b>	Flash PROM update
<b>PC INTERFACE</b>	Ethernet Port (10/100/1000Mhz) USB 3.1 Port ( <i>also supports USB 2.0</i> ) Wireless with external wireless to USB adapter
<b>COUNTERS</b>	Lifetime Piece Counter, Session Counter, Jobs Counter
<b>DIMENSIONS</b>	21.25" H x 28.75" L x 23" W (54 cm H x 73 cm L x 58.4 cm W)
<b>WEIGHT</b>	80 lbs. (36.3 kg.)
<b>ELECTRICAL</b>	<b>Switchable:</b> 115VAC or 240VAC, 50/60 Hz
<b>OPTIONS</b>	Conveyor and Drop Tray

**All Specifications Subject To Change Without Notice**

## APPENDIX B – *Supplies*

The following supply items are available from your Formax Dealer:

### *Supplies*

**INK CARTRIDGES:** Contact your Formax Dealer for a complete list of available ink types and colors.

# INDEX

<b>A</b>	
<b>Alphanumeric Keyboard</b> .....	14
Antenna, Wi-Fi .....	7
Assemble Printer .....	5
<b>C</b>	
Calibration, Touchscreen .....	28
Cartridge Initialize Button .....	28
<b>Cartridges</b>	
Inkjet .....	8, 35
Printhead .....	36
CAUTION .....	36
Choose Location .....	5
<b>Cleaning</b> .....	38
Feed Rollers .....	38
Forwarding Rollers .....	38
Media Sensor .....	38
Printhead .....	36
Touchscreen .....	38
<b>Connect</b>	
Computer .....	7
Network .....	7
Printer .....	7
Wi-Fi Antenna .....	7
Contents of Packaging .....	5
<b>Control Panel</b>	
Feeder ON/OFF Key .....	3
Keys .....	1, 2
Power Off/Reset Key .....	3
Printer .....	1
Quick Menu Key .....	3, 30
Shutdown Printer Buttons .....	28
Touchscreen .....	1, 2, 3
Transport ON/OFF Key .....	3
Transport Pass-Through Button .....	28
Cover, Top .....	1
<b>D</b>	
Date and Time .....	27
Diagnostics .....	26
<b>Display</b>	
Cleaning .....	38
Printer .....	1, 2, 3
Using .....	13
Disposal, Inkjet Cartridges .....	36
<b>E</b>	
Ethernet Port .....	2, 7
<b>Exit Guides</b>	
Adjust .....	9, 10
Location .....	1
<b>F</b>	
Factory Default .....	22
Feed Rollers, Cleaning .....	38
Feed, Set-Up .....	9
Feeder ON/OFF Key .....	3
Firmware Updates .....	29
Forwarding Rollers, Cleaning .....	38
Fuse .....	2
<b>G</b>	
<b>Guides</b>	
Exit .....	1, 9, 10
Rear Media .....	1, 2, 9
Side Media .....	1, 2, 9
Side, Install .....	6
<b>H</b>	
Hardware, Optional .....	43
Horizontal Alignment, Printhead .....	23
<b>I</b>	
Indicator Light, Power .....	1, 2
Ink Estimator .....	25
Ink Nozzles, Purge .....	37
Ink Status .....	25
Ink Type Screen .....	19
<b>Inkjet Cartridges</b>	
Disposal .....	36
Install .....	8
Maintenance .....	35
Replace .....	35
Storage .....	36
Troubleshooting .....	39
<b>Install</b>	
Inkjet Cartridges .....	8
Printer .....	5
Printer Driver .....	11
Rear Media Guide .....	6
Rear Media Support .....	6
Side Guides .....	6
<b>J</b>	
Jams, Printer .....	37
<b>K</b>	
Keys, Control Panel .....	1, 2
<b>L</b>	
Language, Select .....	22
Location, Choose .....	5
Locking Lever, Separator .....	2
<b>M</b>	
Main Menu .....	15
Main Power Switch .....	2
<b>Maintenance</b> .....	35
Cleaning .....	38
Inkjet Cartridges .....	35
Sheet Separators .....	37
<b>Media Sensor</b>	
Cleaning .....	38
Location .....	1
Media Thickness Adjustment .....	1, 2



Messages, Touchscreen .....	41	Purge Ink Nozzles .....	37
<b>N</b>		<b>Q</b>	
Network Port .....	7	Quick Menu Key .....	3, 30
Network Settings .....	26	<b>R</b>	
Nozzles, Printhead .....	37	<b>Rear Media Guide</b>	
<b>P</b>		Adjust .....	9
Pass-Through Button .....	28	Location .....	1, 2
Port Reset Button .....	28	Rear Media Support .....	1, 2
Power Indicator Light .....	1, 2	Rear Media Support and Guide .....	6
Power Off/Reset Key .....	3	<b>Remove/Replace</b>	
Power Receptacle .....	2	Inkjet Cartridge .....	35
Print Image Screen .....	17	Inkjet Cartridges .....	35
Print Units .....	1	Jams, Media .....	37
<b>Printer</b>		Sheet Separators .....	37
Assemble .....	5	Reset Button .....	28
Cleaning .....	38	Rollers, Cleaning .....	38
Connect .....	7	<b>S</b>	
Control Panel .....	1, 2	Sensor, Cleaning Media .....	38
Ethernet Port .....	2	Separator Locking Lever .....	2
Exit Guides .....	9, 10	<b>Set-Up</b>	
Firmware Updates .....	29	Feed .....	9
Fuse .....	2	Network .....	26
Install .....	5	Printer .....	19
Jams .....	37	Wi-Fi .....	27
Main Power Switch .....	2	<b>Sheet Separators</b> .....	2
Maintenance .....	35	Adjust .....	9
Media Sensor .....	1	Maintenance .....	37
Media Side Guides .....	1, 2	Shutdown Button .....	28
Media Thickness Adjustment .....	1, 2	Shutdown/Reset Button .....	28
Network Settings .....	26	<b>Side Guides</b>	
Operating .....	13	Adjust .....	9
Package Contents .....	5	Install .....	6
Power Indicator .....	1, 2	Media .....	1, 2
Power Receptacle .....	2	Sleep Now Button .....	28
Preferences .....	20	Specifications .....	42
Printhead Assembly .....	1	Storage, Inkjet Cartridges .....	36
Rear Media Guide .....	1, 2, 6	Supplies, Printer .....	43
Rear Media Support .....	1, 2, 6	Support, Rear Media .....	2
Set-up Screen .....	19	Switch, Main Power .....	2
Sheet Separators .....	2, 37	<b>T</b>	
Specifications .....	42	Thickness Adjustment, Media .....	1, 2
Supplies & Hardware .....	43	Tools, Printer .....	24
Time Server .....	27	Top Cover .....	1
Tools .....	24	<b>Touchscreen</b>	
Top Cover .....	1	<b>Alphanumeric Keyboard</b> .....	14
Troubleshooting .....	39, 40	Calibration .....	28
<b>USB Port</b> .....	2	Cleaning .....	38
Wi-Fi Port .....	2	Control Panel .....	1, 2, 3
Wi-Fi Set-up .....	27	Diagnostics .....	26
Wireless Status .....	26	Horizontal Alignment, Printhead .....	23
<b>Printer Driver</b>		Ink Estimator .....	25
Install .....	11	Ink Status .....	25
Properties .....	31	Ink Type .....	19
<b>Printhead</b>		Main Menu .....	15
Assembly .....	1	Messages .....	41
Cleaning .....	36	Print Image Screen .....	17

## INDEX

---

Printer Preferences.....	20	<b>U</b>	
Printer Set-up Screen.....	19	Update, Firmware.....	29
Printer Tools.....	24	USB Disconnect Button.....	28
Select Language.....	22	<b>USB Port</b> .....	2, 7
Using.....	13	Using Touchscreens.....	13
Vertical Alignment, Printhead.....	23	<b>V</b>	
Transport ON/OFF Key.....	3	Vertical Alignment, Printhead.....	23
Transport Pass-Through Button.....	28	<b>W</b>	
<b>Troubleshooting</b> .....	39	Wi-Fi	
Inkjet Cartridges.....	39	Antenna.....	7
Printer.....	40	Port.....	2, 7
Touchscreen Messages.....	41	Set-Up.....	27
		Wireless Status.....	26