

FORMAX[®]

Cut-True 22S
Electric Paper Cutter

OPERATOR-PARTS MANUAL
SECOND EDITION

INDEX

CONTENTS

PAGE

Safety Instructions ----- 1

Getting to know your paper trimmer ----- 6

Blade Replacement Instruction ----- 8

Safety Instruction:

Safety Instruction:

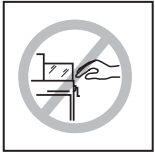

1. Carefully read this instruction manual before operating the machine.
People who operate the machine must read and fully understand how to use the safety equipment, and have the ability to follow and implement the regulations stated in this instruction manual.



2. Keep guards/covers in place.
All components which may endanger the operator are covered by the guards or covers.
Please keep the guards/covers in place and do not remove them without dealer or manufacturer's consent.

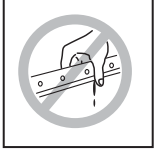

3. Don't use it in a dangerous environment.
Do not use the machine in humid or damp locations, or directly expose it to rain or sunlight.
The working area must be well lit and ventilated.



4. Store idle machine.
If you don't want to use it for a period of time, please store it in a dry and secure environment.



5. Stand in the proper position for operation.
Please stand in front of the machine while operating it.
6. Don't overuse the machine.
Please use it properly and follow the steps for each of the functions stated in the instruction manual.



7. Operate it while you are in good health.
For safety reasons, do not operate the machine when you are tired or unable to focus on the job.

8. Keep both hands away from the cutting area.
The machine is designed to be and only allows a one-man operation. Each single cutting action must be operated by pressing the 2 enable switches simultaneously to avoid injury.

9. Keep away from the sharp edge of the blade.
Please wear leather gloves and use the cutter blade holders to replace or install the blade.

10. Maintain machine with care.
Repairing the machine or sharpening the blade must be carried out by qualified and well-trained people only. If you don't use the replacement parts from the original manufacturer, it may result in considerable danger to the operator.

11. Waste disposal shall obey the local regulations and must be done carefully.

12. The measurement of the noise level is defined according to ISO 3746.
A weighted sound pressure level measuring under no load at operation position is 75.6Db (A), and under load at operation position is 75.5dB (A).

13. Make sure that the machine is disconnected at the power supply.
Shut down the power before starting to do any maintenance, adjustments, or repairs.

14. Application and prohibition of using the machine.
The machine is designed for trimming paper only. For safety reasons, do not attempt to cut other materials such as metal sheets, wood board or other objects.

15. Do not use the machine over its capacity.
Refer to the specifications of the machine shown in the instruction manual. Any modifications to the machine are not allowed and will terminate the manufacturer's guarantee.

16. If any transmission elements fail, do not forcefully drag the paper pile out.

17. To ensure the optimal effectiveness of the machine, the safety devices need to be checked before operation. The test results (see annex A) must be recorded after the blade has been changed or adjusted.

Installation of the machine:

The back-gauge crank, clamp hand wheel with screws and some related tools are separately and properly packed in a box with the machine. Please install these items right away.

The top part of the machine and the stand must be connected as follows:

1. Assemble the stand in the way that the 4 foundations match the colors marked on the stand, and secure each connected part with hexagonal screws.
2. Correctly place and install the machine on the stand with care , and tighten the 4 hexagonal nuts to secure the stand and machine.

Operation Description

1. Push the back-gauge crank slightly toward the machine and turn it counterclockwise in order to load the paper pile on the deck.

 **Note :** To prevent the back gauge device moving forward and backward while cutting, pull the back-gauge crank toward to the operator to make it idle.

2. Turn the clamp hand wheel clockwise to clamp the paper pile and close the safety guard.
3. Push the 2 enable switches simultaneously and hold them until the cutting cycle is complete.
4. The optical cutting line will project the right cutting position on the paper pile.

Specification:

Des. \ Model		22S
Power Supply	-	1~, 120V, 60Hz
Cutting Capacity_ (80gsm paper)	m	1.75" / 45 mm
Max.Cutting Width		16.9" / 430 mm
Max.Cutting Length	mm	430
Min.Cutting Lenth	mm	51
Main Motor Power	mm	0.4 (1/2HP)
Dimensions(LxWxH)	mm	700x625x1200
Weight	K	92



Transportation:

Please refer to the specifications of the machine to arrange a capable lifting device to move the machine.

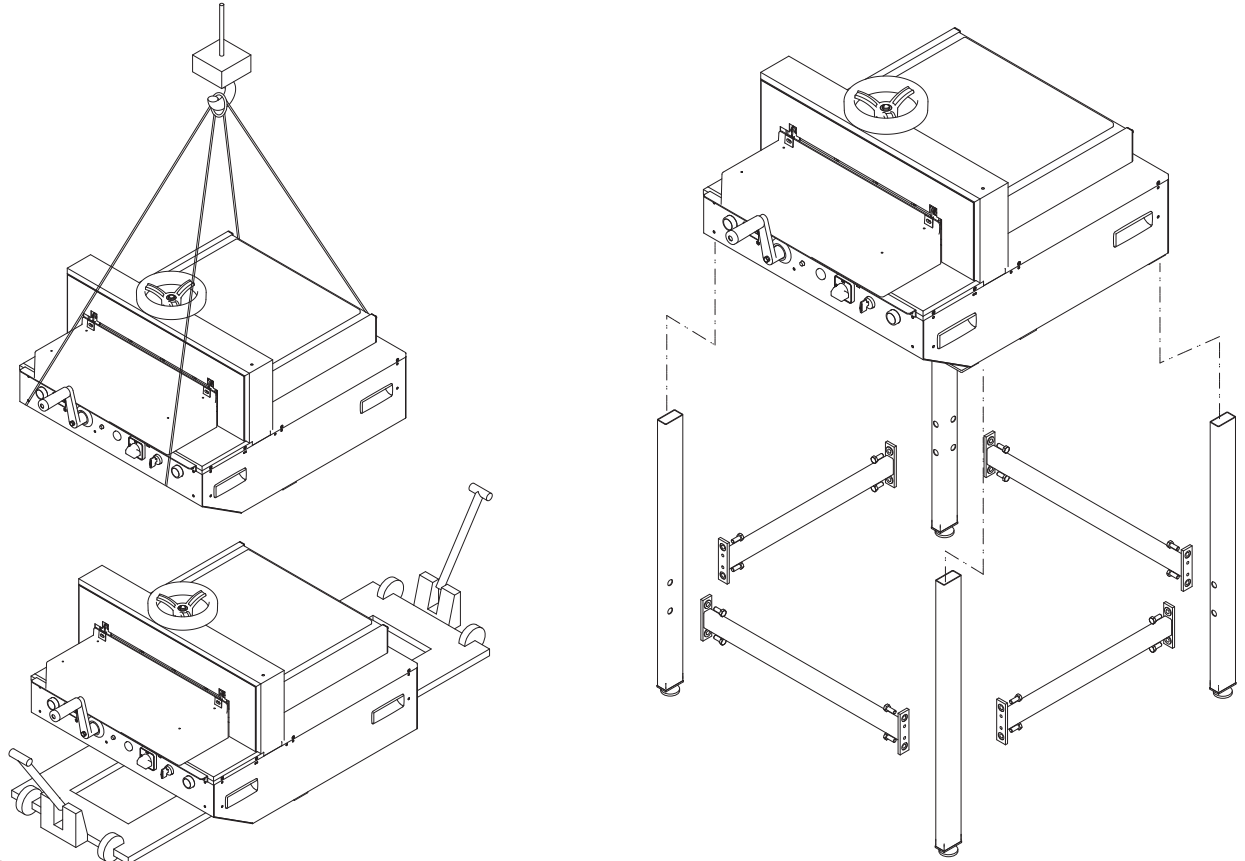

Note : The handling and transportation should be carried out by qualified people only. During handling, people are strictly prohibited from entering the path of the movement of the machine. Please also pay attention to the balance of the machine.

Setting The Machine And Choosing Base:

A clear area must be provided in accordance with the diagram of the machine below. This is essential for efficient maintenance and assembly. Do not put it in locations directly exposed to the sunlight or near a heat source. Please install it in a well-ventilated place which is free of dust.

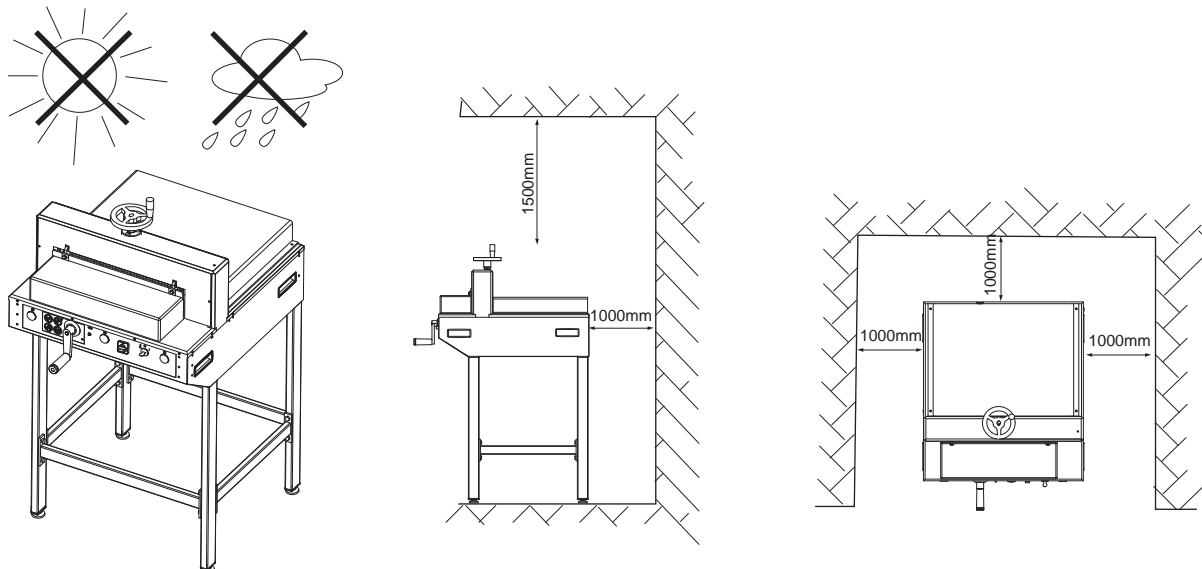

Safety function inspection before use:

1. Be sure to check the safety functions before operation and after replacing the blade.
2. The safety devices (SQ1 and SQ2) are designed in accordance with the EN 60947-5-1-3 requirement and the electronic requirement EN1088.
3. The front safety guard is controlled by SQ1 and SQ2, which follow the requirement EN954-4 category sub.3. The machine and blade will automatically stop when the safety guard is open or disconnected. In contrast, the machine can be operated by pressing the two enable switches simultaneously.

Maintenance and Lubrication:

1. Use a dry cloth to wipe the surface. Do not pour water directly on the machine.
2. Do not use a brush, acid or solvents, such as benzene, hot water...etc. Because it will damage the paint.
3. All movable parts need to be lubricated and oiled from time to time. These parts must be cleaned and free of paper dust and oil deposits before lubricating.

Trouble Shooting:

1. The blade doesn't move. Check if the main motor magnetic contact is activated.
2. Powering off: Check the power source and all the control circuit fuses.
3. Overload. Wait until the breaker automatically resets, it takes around 30- 60 seconds. The indicator light will be off. Please reduce the paper pile or change to a sharp blade.
4. The machine does not work after closing the front safety guard. Press the two enable switches simultaneously again, and check to see if the safety guard is completely closed.
5. If the circuit board needs to be changed, please follow these steps:
 - a. With the power off, remove the old circuit board and put in a new circuit board.
 - b. Once the new circuit board is in place, turn the power on. The message "HOME" will appear. Move the back-gauge to the end until the message "DOWN" appears.
 - c. Turn the back-gauge crank to return the back-gauge into the operating position. The ruler indicator needs to be at the position of 30 cm, and make sure the scale on the back-gauge crank is located at the 0 position.
 - d. Press the reset button for a few seconds until the figure 30.00 shows up on the screen.
 - e. After you see "30.00", cut one sheet of paper and make sure it precisely matches 30cm.
6. If there are any other problems, please contact your dealer.

CUTTING BLADE MAINTENANCE

The cutting blade is made of heat-treated high-carbon steel and is designed for repeated use. However, over time the blade will become dull, and not perform to the highest standards. Cutting heavy paper or cardboard will dull the blade more quickly than thinner paper stock. A dull blade will not cut accurately. Blade lifetime with normal paper is approximately 1600 cuts (tested in maximum capacity).

NOTE: If the blade jams in the paper stack or leaves a groove in the paper, it should be changed immediately.

If the blade is not making clean, accurate cuts, check the following:

- * Have you rotated or replaced the cutting stick?
- * Have you correctly adjusted the height of the blade?

If so, the blade will need to be replaced. The blade can either be re-sharpened by a professional, or it can be replaced with a new blade. To avoid injury, follow the Blade Changing Procedure and use the Blade Change Safety Tool, included with the cutter.

ROTATING / REPLACING THE CUTTING STICK

The cutting stick is the surface the blade contacts during the cutting process. It can be rotated and used on each side, 4 times altogether.

If the last piece of paper in the stack is not cut through cleanly, and the blade depth has been adjusted properly, the cutting stick should be rotated or replaced.

The cutting stick sits in a channel in the base of the cutter, just below the blade carrier. To remove it, first turn off the power. Then insert the 5mm screwdriver into the cutting stick access slot (see photo below left) and lift up. Grasp the cutting stick and remove (see photo below right). Rotate the cutting stick to a new side and re-install.

NOTE: When the cutting stick is rotated or replaced, the blade height must be readjusted. See the next page for blade height adjustment instructions.

ERROR MESSAGES

“**CUT2000**” appears in the LED display: The blade has completed 2000 cutting passes. Check the blade to see if it is dull or still sharp enough to cut through one sheet of copy paper.

If the blade is still sharp and does not need to be replaced, reset the counter with the following steps:

1. Turn the select switch key to the right.
2. Press and hold the right enable switch for at least 5 seconds, while simultaneously turning the select switch key back to the middle position until the message “CAT” appears in the LED display.
3. Release the right enable switch.

“**E4**” appears in the LED display: Remove the T-Wrench from the fine adjustment device.

“**E5**” appears in the LED display: Cutting drive motor is overloaded.

“**E6**” appears in the LED display: The blade couldn't return within the standard period of time after cutting.

Getting to know your paper guillotine:

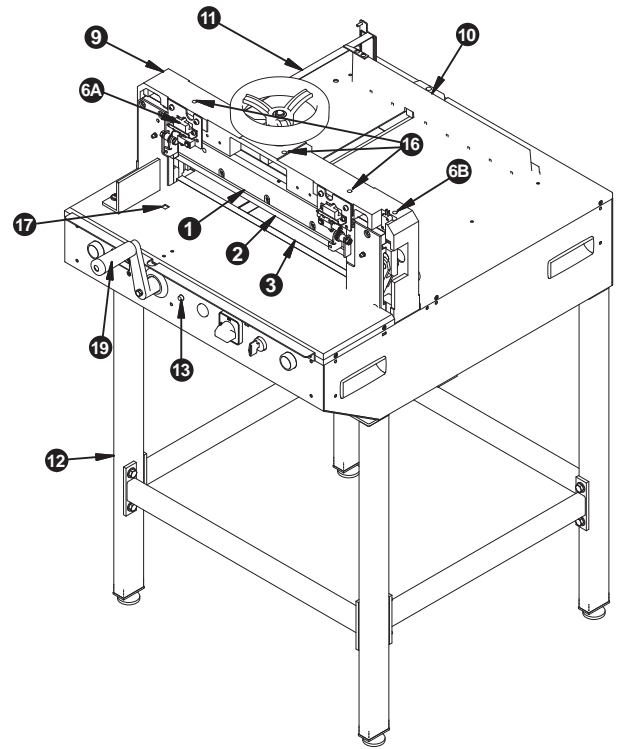
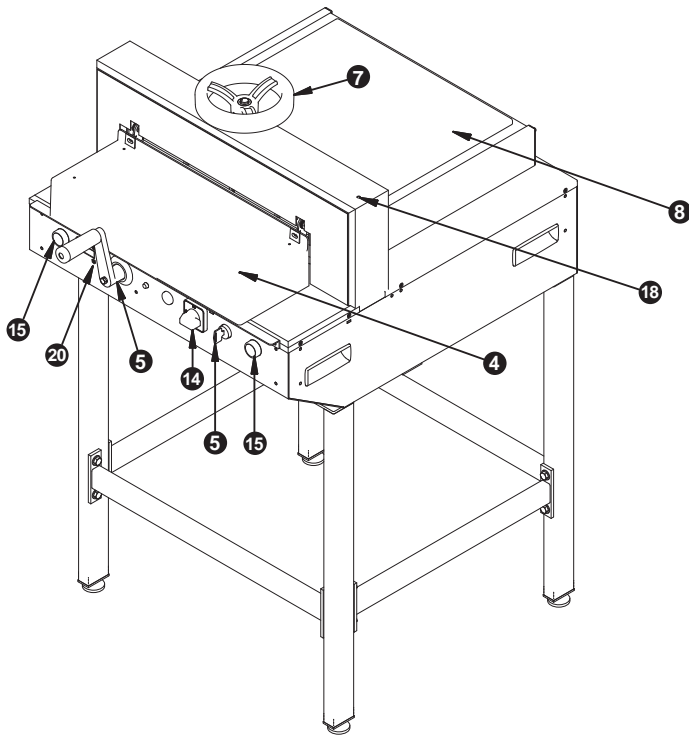

① Blade holder

There are 5 screws for positioning the blade on the blade holder.

② Blade

It's made of high quality carbon steel and needs to be installed and removed step by step following the blade replacement instructions.

③ Cutting Stick

It's made of tough plastic to protect the edge of the blade. Each of its four sides can be used.

④ Safety Guard

The safety guard must be closed properly before cutting, so the interlock device will be released.

⑤ Select switch:

Turn it to the right for conducting cutting procedures, and turn it to the left for blade replacement procedures. Keep it in the middle to stop all operations.

⑥ Safety Guard System(Interlock Device)

Interlock device A: The machine can be operated only when the safety guard is closed completely.

Interlock device B: For the safety reasons, the machine cannot be operated when the 5 mm T wrench is still in the blade adjustment device.

⑦ Clamp Hand Wheel

Turn it clockwise to clamp the stack of paper tightly.

⑧ Cover

Attached to the machine with two screws. You are only allowed to remove it for changing the blade or doing maintenance.

⑨ Carrier(Cutter Base)

It's purpose is to carry the blade holder and the entire mechanism.

⑩ Back-gauge

It's controlled by the back-gauge crank which can be adjusted to the desired cutting size and parallel align the stack of the paper to be cut.

11 Side Gauge with Scale

Measurement in mm/cm and inches. The indicator on the back-gauge will point out the current measurement. The fine adjustment can be done via the scale ring. The minimum adjustment is 0.5mm.

12 Stand

The standard equipment of vj g'EwVtwg 22S is made of steel.

13 Overload lamp

The overload protection device will turn off the power automatically while unusual heavy loading occurs. A blunt blade may cause the overload protection to shut down the machine.

14 Power Switch

15 2 enable switches

16 3 socket headless screws for adjusting the balance of the blade after changing to a new blade.

17 Functional hole for lifting up the cutting stick

18 Fine adjustment device for the blade

The scale is only 0.2 mm. Turn it clockwise to raise the blade up.

19 Back-gauge Crank

Pull the back-gauge crank toward the operator in order to make it idle and to avoid the measure moving forward or backward.

20 Digital Measurement readout

It can be switched over from cm to inches and vice versa. This function is only on vj g'EwVtwg"44U

Blade Replacement Procedure

1. Turn the power switch ON, and turn the select switch to the left.

Select switch in blade change position

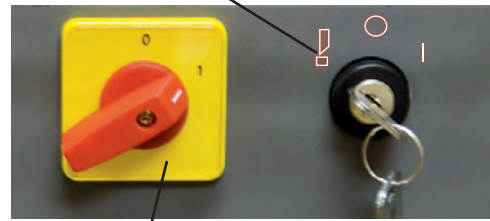

Power switch in ON position

2. Press two enable switches simultaneously to move the blade down to the bottom position.



3. Turn the select switch to the middle and turn off the power. Then lift the plexi safety cover to remove the first screw from the right side of the blade (A).



A

4. Close the safety cover and turn the select switch to the left. Then turn on the power. The blade will move up automatically. Turn the select switch to the middle and turn off the power.



B

C

Center screw

D

5. Raise the safety cover and remove the first screw from the left side (B). Remove the screws to the left and right of center (C & D), but leave the center screw in place.

NOTE: Do not remove the center screw.

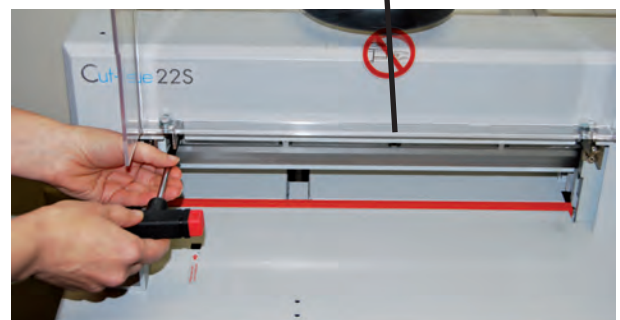

6. Remove the blade change safety tool from the tool box and screw the handles into the two holes to the left and right of center (see photo). Screw them in tightly, to prevent the blade from falling out of the holder.

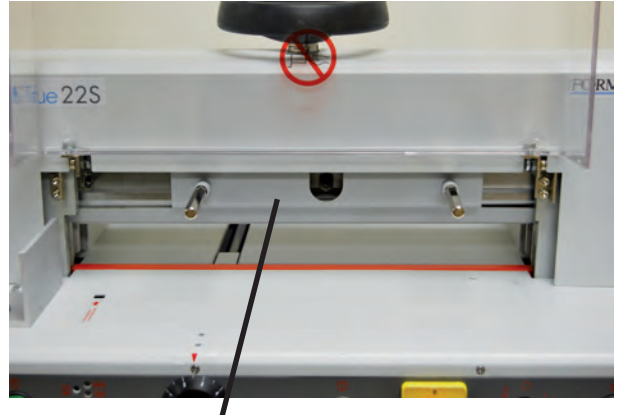
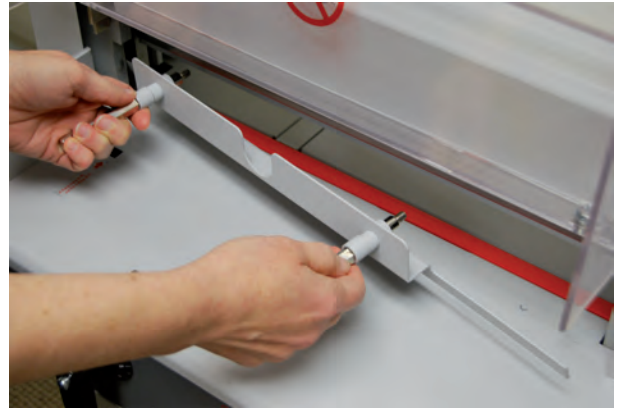

Blade change safety tool in place

7. Remove the center screw.



8. Grip and loosen both of the blade change tool handles by turning just a half reverse turn to remove the blade from the machine. Carefully move the blade and holder downward in order to remove it safely from the machine. NOTE: Be careful to avoid injury from the very sharp blade.



9. Carefully remove the old blade from the blade change safety tool. Set it on a flat surface and unscrew the handles. Cap the old blade with a protective pad to prevent injury.

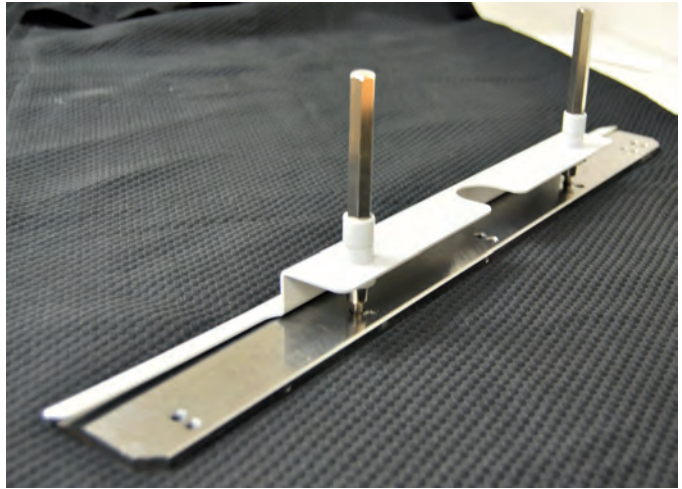

10. Place the new blade with the beveled cutting edge facing up, and the screw holes at the top, as shown here. Remove the protective pad from the new blade.

To attach the blade change tool, place it over the blade and screw the handles into the lower set of screw holes. Then reverse the procedure to install the new blade.

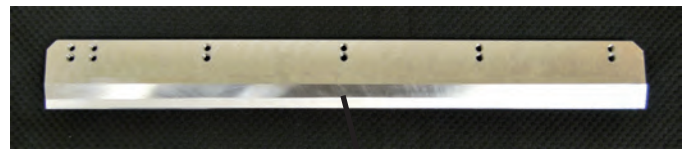

Beveled cutting edge

Appendix A

Inspection for safety device function of the machine

MODEL:

SERIES:

DATE:

Checker:

Content	Result	OK	Fail	Remark
Safety guard is closed	Press 2 enable switches. The blade will go down.			
Safety guard is open	Press 2 enable switches . The blade can't go down.			
One hand to close the safety guard and the other hand to press one of the 2 enable switches	No action.			
Cutting Performance	If one sheet of paper can not be cut through completely, finely adjust the blade height and try to cut again.			Remove the T-wrench before turning on the power.

PARTS

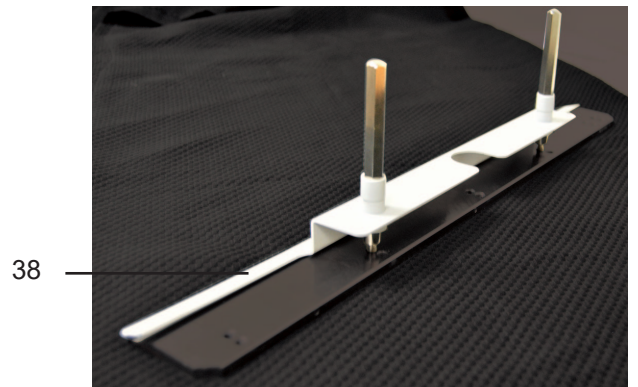
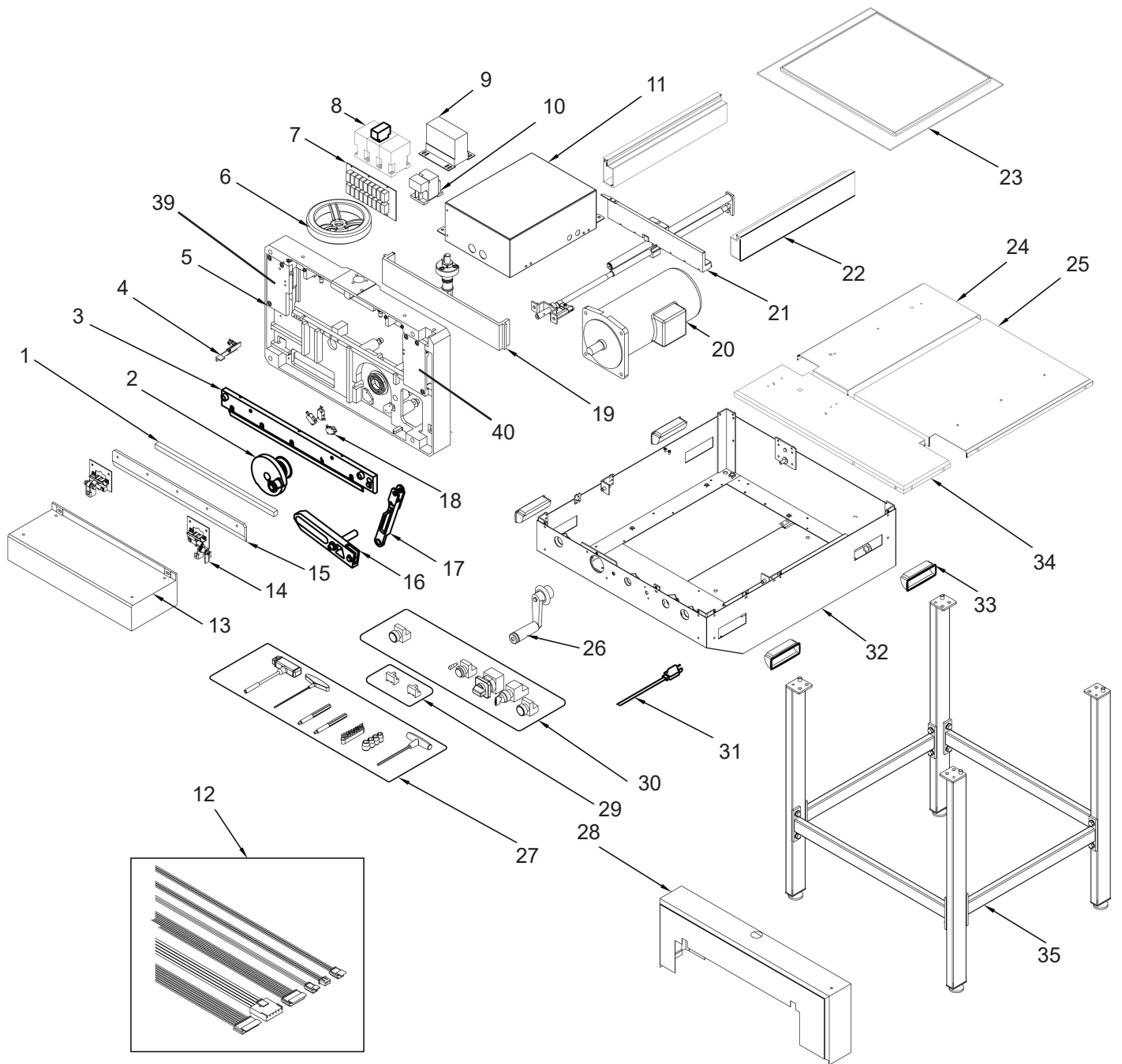

PARTS

ITEM	PART #	DESCRIPTION	QTY
1	15M-20	CUTTING STICK (pkg of 8 when ordering)	1
2	51033	GEAR SET	1
3	51018	BLADE CARRIER	1
4	51026	CUTTING STICK REMOVAL LEVER	1
5	51020	BLADE HOUSING	1
6	51025	HAND WHEEL FOR PAPER CLAMP	1
7	51022	IC BOARD	1
8	51031	MAGNETIC CONTACTOR & SWITCH	1
9	51029	TRANSFORMER	1
10	51030	THERMAL RELAY	1
11	51024	ELECTRICAL ASSEMBLY	1
12	51028	RIBBON/PIN CABLE SET	1
13	51005	FRONT SAFETY COVER	1
14	51010	SWITCH/MOUNT FOR FRONT SAFETY COVER	2
15	22S-10	BLADE	1
16	51034	LOWER LEVER ASSEMBLY	1
17	51035	UPPER LEVER ASSEMBLY	1
18	51019	FINE SWITCH SET	3
19	51021	PAPER CLAMP	1
20	51012	MOTOR	1
21	51013	BACK GAUGE WITH CONTROL UNIT	1
22	51032	SIDE GAUGE WITH SCALE	2
23	51023	REAR SAFETY COVER	1
24	51008	LEFT TABLE	1
25	51007	RIGHT TABLE	1
26	51002	BACK GAUGE CRANK HANDLE	1
27	51011	TOOL KIT	1
28	51009	TOP COVER	1
29	51014	SAFETY SWITCH	2
30	51015	SWITCH ASSEMBLY	1
31	51027	POWER CORD	1
32	51003	BASE ASSEMBLY	1
33	51004	PLASTIC HANDLE	4
34	51006	FRONT TABLE	1
35	51001	STAND	1
36	W01100592	FOOT BLOCK	4
37	W01100593	ADJUSTABLE FOOT	4
38	06400121	BLADE CHANGE TOOL FOR 22S	1
39	03302131	LEFT BLADE FASTENING PANEL A	1
40	03302132	RIGHT BLADE FASTENING PANEL B	1
-	KEY22/27	REPLACEMENT KEY	1
-	05000066	IC WITH LED LIGHTS	2
n/a	51922	BLADE MOUNTING BOLT SET - 22M	1
-	05800054	15A fuse	1

ELECTRICAL SCHEMATIC

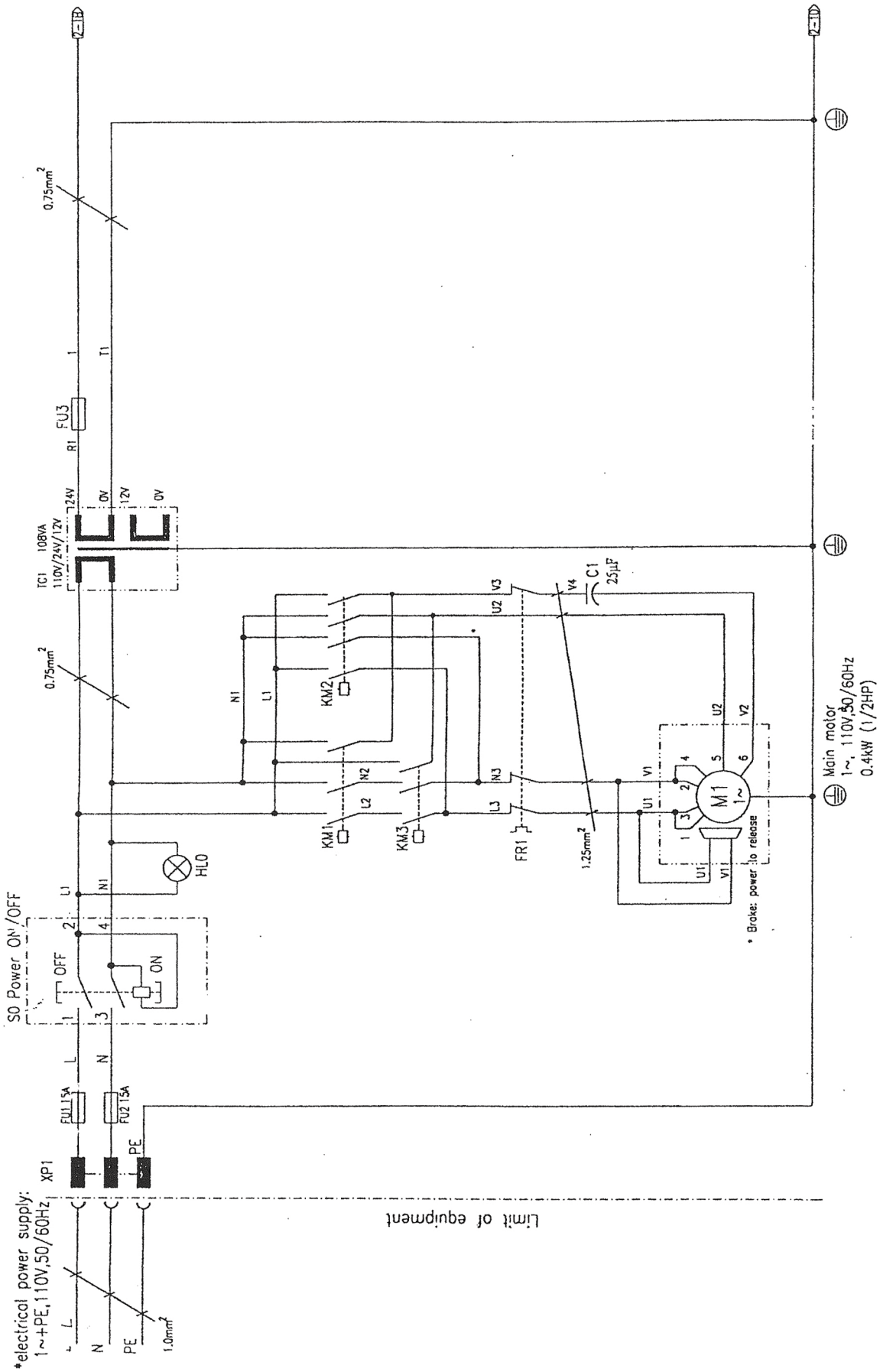

ELECTRICAL SCHEMATIC

