

# FORMAX<sup>®</sup>

---

FD 346 / FE 346  
Document Folder  
FI / FJ Series

MAINTENANCE & PARTS MANUAL  
FIRST EDITION



# TABLE OF CONTENTS

<b>SUBJECT</b>	<b>PAGE</b>
DESCRIPTION	1
SPECIFICATIONS	1
UNPACKING	2
SETUP	2
CONTROL PANEL	3
OPERATION	4
SETTING CUSTOM FOLDS	5
AUTOBATCH MODE	5
MULTI-SHEET FEEDING (OPTIONAL)	6
CROSS FOLDING	7
STACKER WHEEL POSITIONING CHART	7
STACKER WHEEL SETUP FOR THICK PAPER	8
REMOVING OUTFEED COVER	8
REMOVING INFEED TIRES	9
OPERATOR MAINTENANCE	9
ERROR SCREENS	10
TROUBLE-SHOOTING	11
MANTENANCE	12
SERVICE MODE	16
ELECTRICAL SCHEMATIC	17
PARTS	18





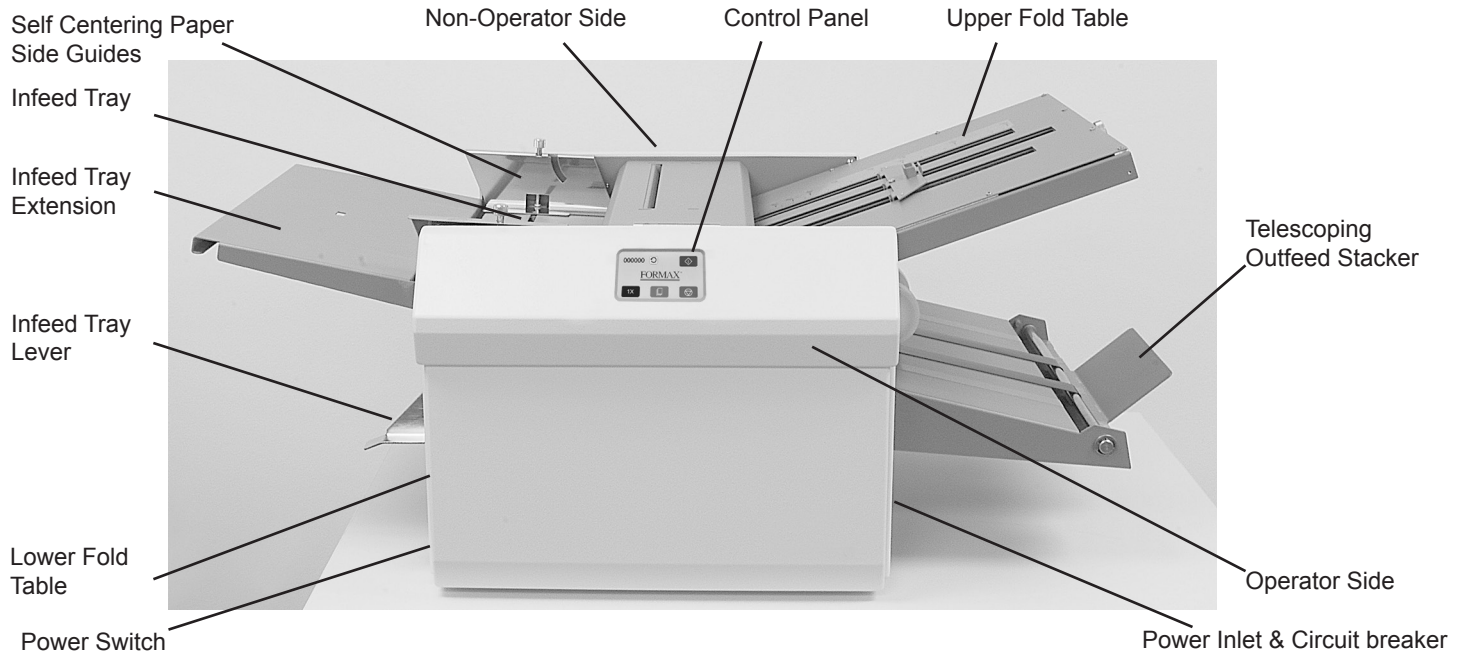



# DESCRIPTION



## FUNCTION

This document folder is designed to perform a wide variety of folds using a variety of paper weights. The fold plates are manually adjusted for standard folds and custom folds. Batch counting, self-centering side guides, and the capability to cross-fold are added features. The folder will automatically stop after the last document has been folded.

## SPECIFICATIONS

Speed:	Standard Mode: Up to 15,500/hour, depending on fold type
Hopper Capacity:	Up to 500 sheets of 20# paper (75gsm)
Paper size:	Min: 3.5" X 5" (88.9 W x 127 L mm) Max: 12.25" X 18" (311 W x 457 L mm)
Pre-Marked fold types:	Letter  , Zig-Zag  , Single  , Gate  , Fold Out  , Double Parallel 
Pre-Marked Paper Sizes:	FD Model: 11", 14", 17" FE Model: A5, A4, A3, B6, B5, B4
Weight:	67 lbs (30 kg)
Power:	FD Model: 120 volts A.C., 50/60 Hz, 2 amps. FE Model: 220 volts A.C., 50/60 Hz, 2 amps
Safety Certifications:	UL, CUL, & CE Approved

# UNPACKING & SETUP

1. Check package for shipping damage. If there is shipping damage, do not discard the box.
2. Remove the machine and packed components from the box. The fold plates, telescoping stacker, Optional Multi Sheet Feeder if ordered, power cord and cross-fold guide are wrapped separately in the box.

**NOTE:** Two people must lift the machine from the box.

3. Place the folder on a solid wooden or metal stand.

## Install upper and lower fold plates, telescoping conveyor multi-sheet feeder and power cord

1. Be sure the plates are set firmly on the locating pins (Fig 1a & 1b). Slide each fold plate in until it meets the first locating pin then push down to set in place.

Upper Fold Table Pins



Fig. 1a

Locating Pins

2. Repeat the same steps for the lower fold plate.

Lower Fold Table Pins

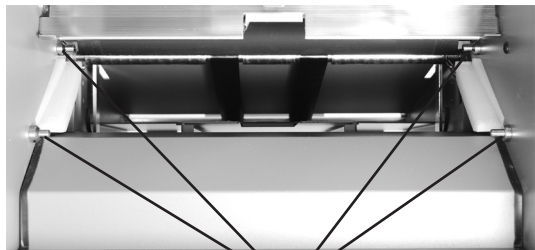

Fig. 1b

Locating Pins

3. Insert the telescoping extension tray into the end of the outfeed conveyor (Fig. 2).

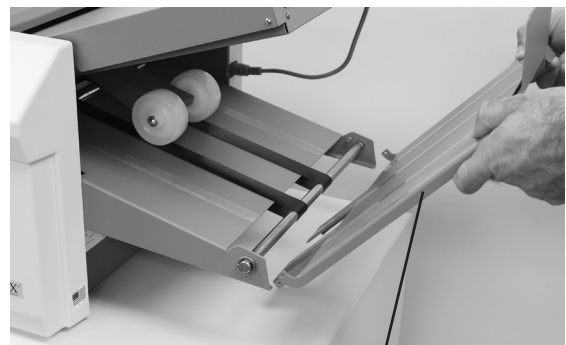

Fig. 2

Telescoping extension tray

- If equipped, insert the optional Multi-Sheet Feeder into the four slots located on the top cover (Fig 3).

**Note:** Technical assistance is required to install the multi-sheet feeder components if it is purchased separately from the folder.

- Make sure the power switch is in the “OFF” position. Plug the power cord into the power inlet and the wall outlet.

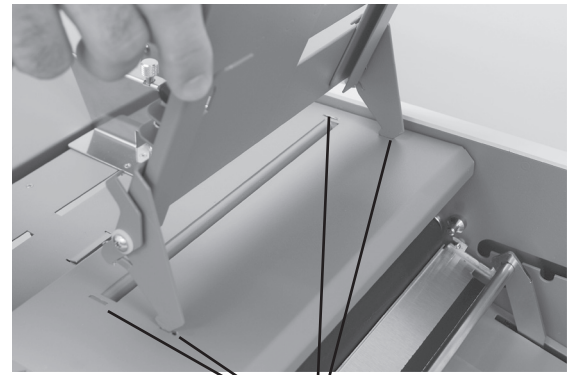
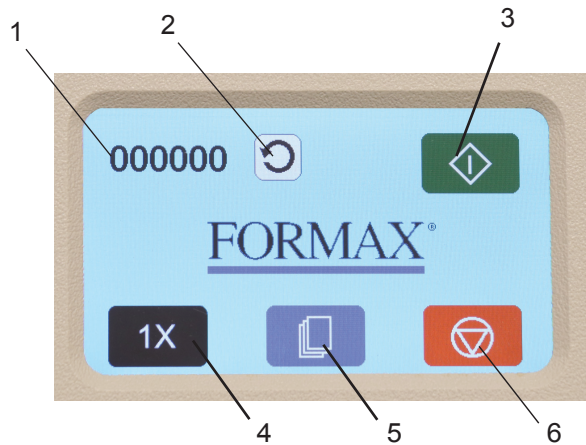

Fig. 3

4 Slots

## CONTROL PANEL

### Main Screen:



### AutoBatch Mode Screen:

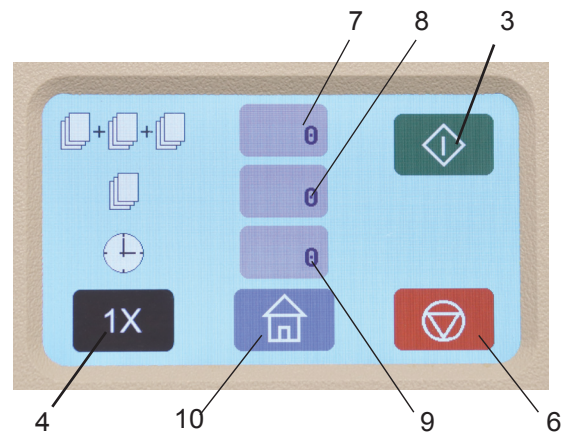

No.	NAME	FUNCTION
1	Counter Display	6-digit resettable counter
2	Counter Reset Icon	Resets the counter to “000000”
3	Start Icon	Press to start the Folder
4	“1X” Icon	Test folds one document
5	AutoBatch Mode Icon	Press to enter the Batch mode
6	Stop Icon	Press to stop the folder
7	AutoBatch Mode: Number Folded Sets	Press to enter the number of batched sets (up to 999 sets)
8	AutoBatch Mode: Number of documents	Press to enter the number of documents in a batched set (up to 999 documents)
9	AutoBatch Mode: Delay between sets	Press to enter the time delay between each set (up to 99 seconds)
10	Home Icon	Press to return to the main screen

# OPERATION

1. Place power switch in the "ON" position.
2. To set the fold plate stop position, squeeze the stop plate lever and move the stop plate to the desired location on the upper and lower fold plates (Fig 4). Align the pointed part of the stop plate with the desired marks on the decal and release the lever. Fine adjustments can be made with the adjustment knob at the end of the plate (Fig 5).

**NOTE:** When doing a "Single" fold, be sure to move the lower fold plate stop all the way to the front of the plate. The plate must be firmly reinstalled on the locating pins.



Fig. 4

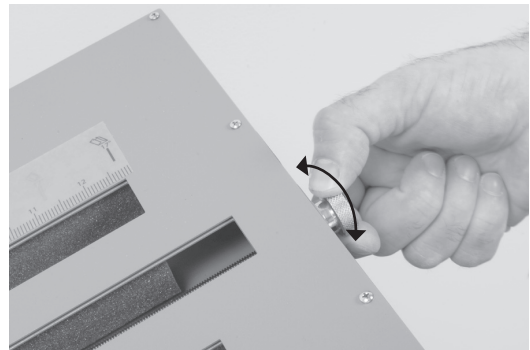

Fig. 5

3. Move the stacker wheels to the proper position for the paper size (Fig 6) ( Refer to chart on page 7).
4. Extend the telescoping conveyor stacker as required.
5. Lift the in-feed tray extension into position.
6. Raise the in-feed tray lever.
7. Set the paper side guides for the paper you're using and lock in position.
8. Neatly stack paper on the in-feed tray.
9. Lower the in-feed tray lever.
10. Press the "1X" icon on the control panel to check the folds. Adjust as needed.
11. If the fold is skewed use the skew adjustment knob to make corrections (Fig.7).
12. When you're satisfied with the test folds, press the "▶" icon to operate the machine.

Stacker Wheel Positions A, B & C

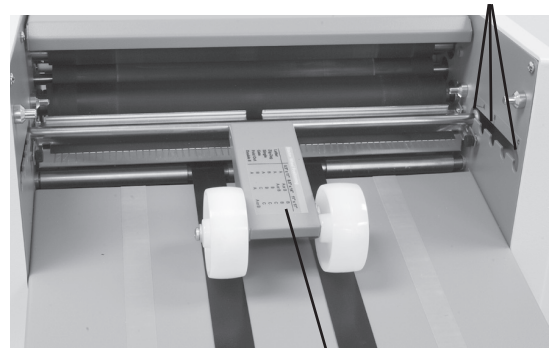

Fig. 6

Stacker Wheels



Fig.7

Skew Adjuster



# SETTING CUSTOM FOLDS

## Example 1: Uneven “Z”

1. Measure the length of panel “A”
2. Adjust the upper fold plate so that the stop plate lines up with the measurements of the panel “A” i.e. if panel “A” is 5 1/4” long slide the stop plate up or down so that it lines up with the 5 1/4” mark on the fold plate.
3. Measure the length of panel “B”
4. Adjust the lower fold plate so that the stop plate lines up with the measurement of panel “B”
5. Load forms and press test. If folds are too long or too short adjust accordingly.

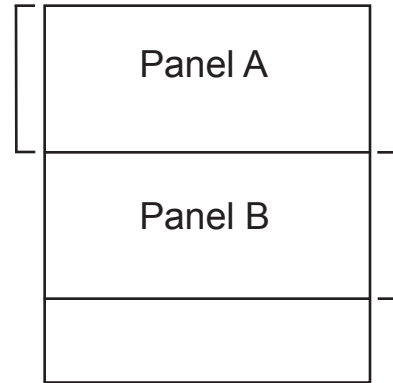



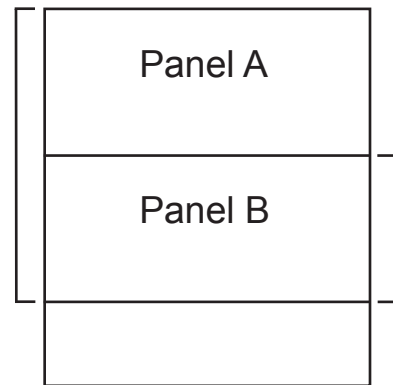

## Example 2: Uneven “C”

1. Measure the length of panel “A” & “B”
2. Adjust the upper fold plate so that the stop plate lines up with the measurements of panel “A” & “B”. i.e. if panel “A” & “B” are 10 1/2” long slide the stop plate up or down so that it lines up with the 10 1/2” mark on the fold plate.
3. Measure the length of panel “B”
4. Adjust the lower fold plate so that the stop plate lines up with the measurement of panel “B”
5. Load forms and press test. If folds are too long or too short adjust accordingly.



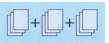

# AUTOBATCH COUNTING MODE

The AutoBatch feature can be set to count down the number of sets in a batch, the number of sheets in each set, and the delay between each set. To enter the AutoBatch Mode press the “” icon on the main screen.

To enter the number of sets press the “” (fig. 8a). Enter the number of sets on the keypad that appears. Next press the “” icon to select the number of sheets, and then press the “” icon to enter the delay between sets. Press the “” to exit the keypad.

Press the “” icon to begin folding. The folder will stop when the number of sets counts down to zero (0).

To exit the AutoBatch Mode press the “” icon.

Note: Press the “” icon on the keypad to exit back to the Auto Batch screen. Press the “” icon to edit the number entered. Press the “” icon on the keypad to reset the entered number to zero (0).

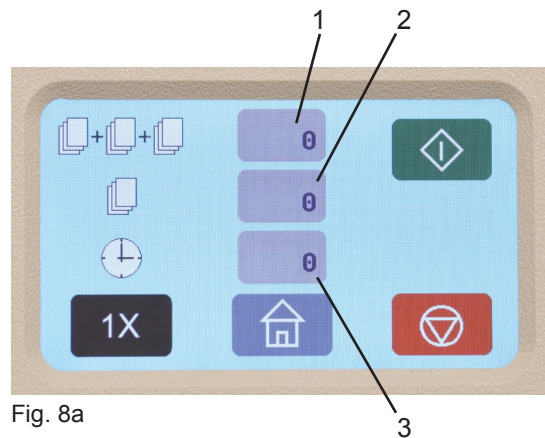

Fig. 8a

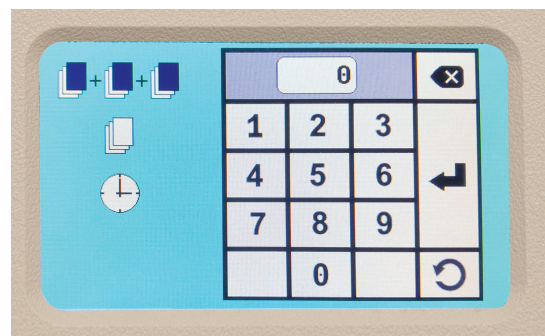

Fig. 8b

## MULTI-SHEET FEEDING (OPTIONAL)

The multi-sheet feeder is designed to fold pre-collated stapled or unstapled sets of up to four 20 # (75gsm) sheets of paper. **NOTE:** This feature will not work in AutoBatch mode. The home screen must be displayed in order for the multi-sheet feeder to work properly.

1. Adjust the side guides on the multi-sheet feeder for the proper paper size. Loosen the thumb screw, adjust the guides to fit the paper width and re-tighten the thumb-screw (Fig 9a).
2. Slide the pre-collated paper set into the multi-sheet feeder. When feeding stapled sets the documents should be placed with the staple on the operator's side and leading (Fig 9b).
3. The sheets of paper will be automatically pulled into the folder.
4. If the fold is skewed, turn the skew adjustment knob located on the back of the feeder left or right to make corrections (Fig 9c).
5. To remove the multi-sheet feeder depress the release levers located on either side of the lower back side of the feeder (Fig. 9d), tilt the feeder forward and lift. To reinstall depress the levers and reinsert.



Fig. 9a

Brass thumbscrew

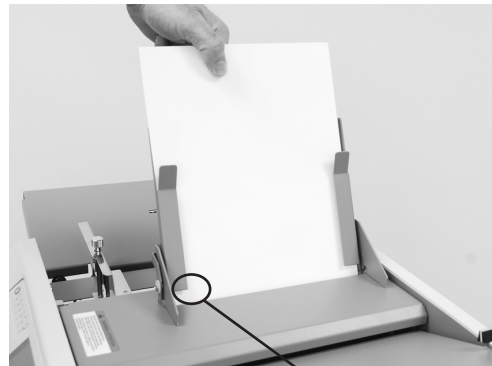

Fig. 9b

Staple

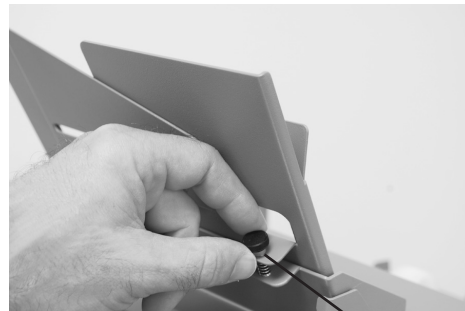

Fig 9c

Skew Adjuster

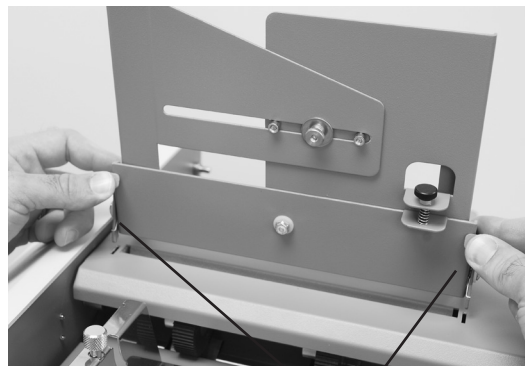

Fig. 9d

Release Levers

# CROSS FOLDING

Cross folding refers to folding a document in one pass and then running it through the folder a second time to be folded again.

Common Application: Folding a 11" x 17" document in half and then letter folding it to fit in a standard #10 envelope.

1. Load folded paper into the feed tray with the fold crease facing the non-operator side of the folder (Fig 10a).

**Note:** For best results, firmly run your hand over the fold crease to help flatten the paper before loading.

2. Attach the cross fold paper guide onto the feed tray paper guide (Fig. 10b) and lower guide.

**Note:** Cross folding ability will vary based on the paper weight and type. If the paper is too heavy it may not be able to be cross folded.

**Note:** The guide can be conveniently stored under the lower fold table when not in use (Fig 10c).

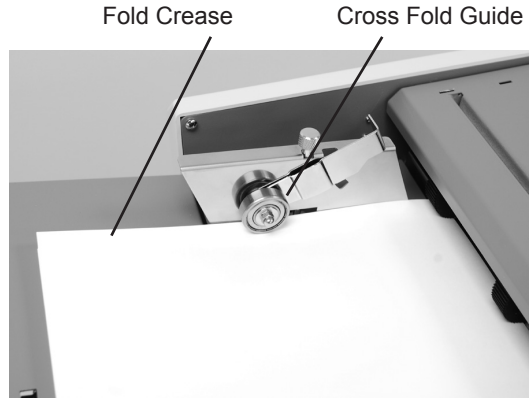

Fig. 10a

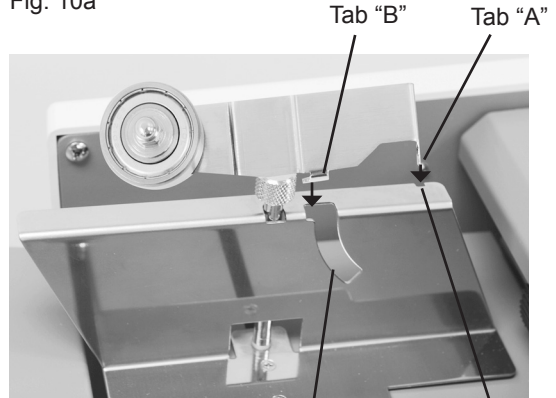

Fig. 10b

To install cross fold guide hook tab "A" into slot "A" and then lower tab "B" into slot "B"



Fig. 10c

Cross fold guide storage

# STACKER WHEEL POSITIONING GUIDE

Move the stacker wheels to the proper position indicated on the chart based on the fold and paper size (Fig 11a and 11b).

	8.5" x 11"	8.5" x 14"	11" x 17"
<b>Letter</b>	A	A or B	B
<b>Zig-Zag</b>	A	A or B	B
<b>Single</b>	B	B	C
<b>Gate</b>	A	B	C
<b>Fold Out</b>	B	C	C
<b>Double II</b>	A	A	A or B

Fig. 11a

Stacker wheels decal

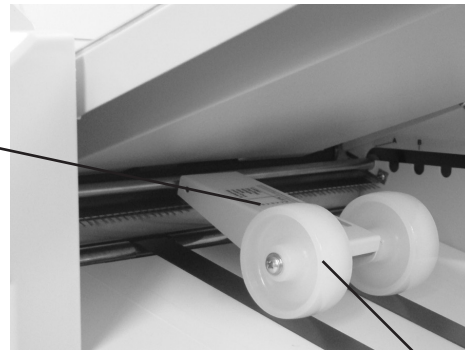

Fig. 11b

Stacker Wheels

## STACKER WHEEL SETUP FOR THICK PAPER

Thicker paper from 28 # up to 65 # may require special stacker wheel setup moving the stacker wheels closer than the position “A” slot.

If stacking is inconsistent move the stacker wheels from the standard position #1 (Fig. 12a) to the thick paper weight position #2 (Fig. 12b) as indicated in the pictures below, position # 2 may also be good for small folded documents.

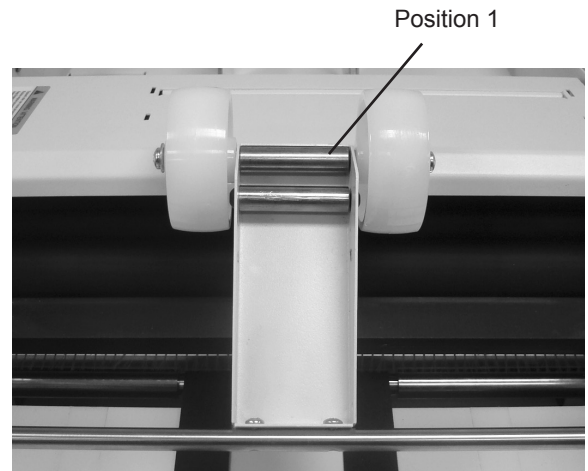

Fig. 12a - Standard Stacker Wheel Position

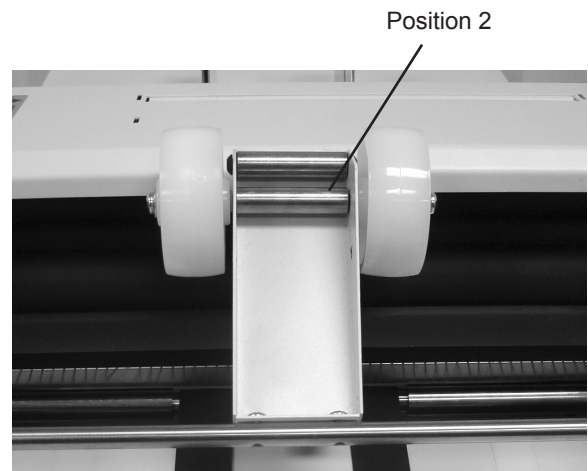

Fig. 12b - Thick Paper Weight Position

## REMOVING OUTFEED COVER

The outfeed cover can be removed to access the exit roller. To remove, unscrew thumbscrews that hold the cover in place (Fig. 13)

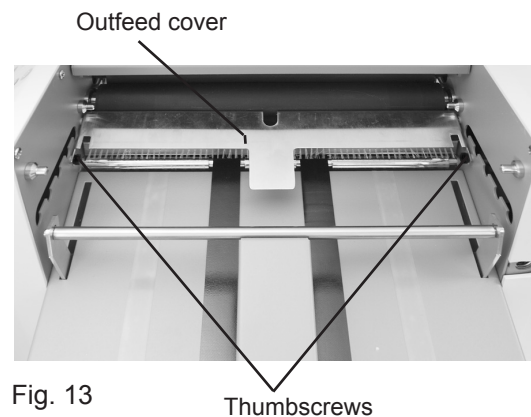

Fig. 13

## REMOVING INFEED TIRES

The infeed tires can easily be removed for cleaning and replacement. Remove the Allen screw located on the left side of the feed tire shaft (Fig. 14a). Slide the shaft to the right to release from the side frame and remove (Fig. 14b).

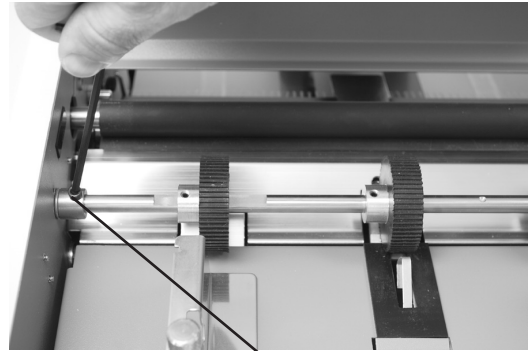

Fig. 14a Allen Screw



Fig. 14b

## OPERATOR MAINTENANCE

1. It is recommended to let forms cool for one-half hour, from the laser printer, before folding. This allows toner to set on the forms and static electricity to discharge. The FD 402 Jogger is recommended for best results. The Jogger squares the forms and dissipates heat and static electricity created by laser printers.
2. Clean in-feed tires and fold rollers with Formax recommended roller cleaner & rejuvenator to remove paper dust and toner. A Formax Cleaner Kit is available from your dealer. A damp cloth with water is the best alternative.

**CAUTION:** Do not use any chemicals other than the roller cleaner & rejuvenator or water.

### CLEANING PROCEDURES:

1. Make sure machine is turned off and unplugged. All folders have four (4) rubber rollers (Fig. 15).
2. Remove the upper and lower fold plates.
3. Using Formax roller cleaner, spray a new cotton cloth until the cloth is saturated. Wipe the wet cloth in a back and forth motion making sure to clean the entire surface of the fold rollers. Next use a dry cloth and wipe off excess toner. The cloth should be covered with black toner surplus from cleaning the rollers.
4. Run 10-15 sheets of blank copy paper through the folder to ensure all cleaner has been removed from the fold rollers. Running blank sheets will remove any excess residue of cleaner on the rollers.

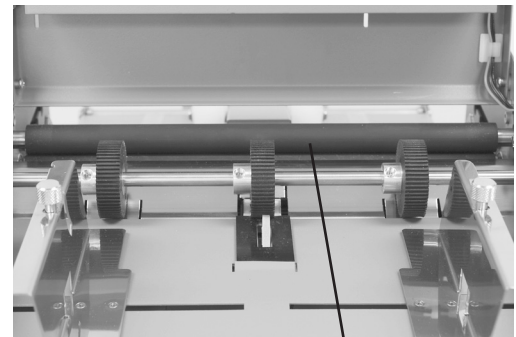



Fig. 15 Fold Rollers

# ERROR SCREENS

## Paper Mis-Feed / Paper Jam



A mis-feed has occurred. Reset the stack of paper in the in-feed and press the “” icon to resume operation. A Paper jam has occurred in one of the areas indicated. Turn the folder to the off position and unplug. Check the area indicated for paper and remove. Replace the fold plates and plug the folder in and the power on.

## Paper Out

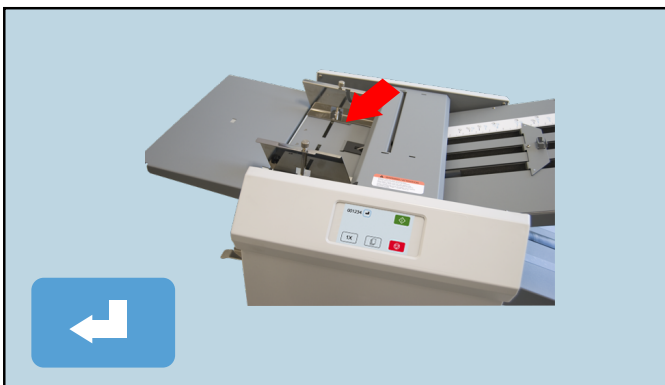

There is no paper in the in-feed. Reload paper and press the “” icon to resume operation.

## Cover Open



The top cover is open. Close the top cover and press the “” icon to resume operation.

# TROUBLE-SHOOTING

TROUBLE	POSSIBLE CAUSE	REMEDY
Control panel is not illuminated.	No power at the wall outlet. No power to the machine inlet. No power to the control panel. Blown Fuse  Internal electrical failure	Check wall outlet.  Check power cord for frayed/broken wires.  Press the button on the circuit breaker.  Change the fuse located on the control panel board  Call Technical Support
"Cover Open" screen.	Cover open  Magnetic switch is broken.	Close cover  Replace magnetic switch
"Paper out " screen.	In-feed tray is empty.  Bad switch	Place documents on the in-feed tray.  Replace Switch
"Fault detect" screen.	Paper misfeed  Paper jammed at exit of folder.   Bad photo-eye	Reload paper.  Remove paper. Check that the out-feed wheels are properly positioned, refer to the guide on the stacker wheel arm.  Replace photo-eye
Black marks on the folded paper.	In-feed tires, separator, and/or fold rollers are dirty.	Clean the parts with approved roller cleaner and rejuvenator.
Fold is skewed.	In-feed tray is out of adjustment.  Fold stop skewed	Turn skew adjuster knob to remove the skew.  Square fold stop
Stacker belts do not turn.	Out-feed tray is not properly installed.  Broken drive belt, worn drive gear.	Reinstall tray and extend to make sure it is properly installed.  Replace drive belt.
Documents are wrinkled or crunched.	Fold plates are not inserted correctly.  Piece of paper or other material is stuck in the fold plate.	Remove and reinstall fold plates. Be sure they're properly positioned.  Remove object from the fold plate.
In-feed tray lever does not work	Broken spring	Replace spring
Double feeding forms	Documents stuck together  Feed tire or separator worn	Jog forms to remove static electricity.  Replace feed tire / separator
Not feeding documents	Feed tire dirty  Feed tire or separator worn  Clutch pulley shaft pin has come out or broken.	Clean feed tire  Replace feed tire / separator  Replace the the pin.
Multi-Sheet feeder not working	Folder is in AutoBatch Mode  Photo-eye not working properly	Select the "  " icon to return to the home screen.  Replace photo-Eye

## REPLACING SIDE COVER

1. Remove the four screws that secure each cover to the side frame. To avoid scratching the operator side cover, raise the feed table lever.
2. Reverse procedure to install.

## REPLACING CONTROL PANEL BOARD

1. Make sure machine is turned off and unplugged.
2. Remove the operator side cover.
3. Remove the two mounting screws holding the control panel to the side frame (Fig 17).
4. Remove the control panel.
5. Unplug the electrical connectors. Note their location.
6. Remove the eight ¼" nuts holding the board to the panel. Do not lose any of the eight white plastic spacers
7. Reverse procedure to install.



Fig. 17

Mounting screws

## REPLACING DRIVE MOTOR

1. Make sure machine is turned off and unplugged.
2. Remove non-operator side cover.
3. Remove lower fold plate.
4. Remove three screws holding the component access panel in position (Fig 19).
5. Remove component access panel.
6. Unplug motor electrical connector (J4) from main power board.
7. Remove tie wraps from wiring harness.
8. Remove the four mounting screws that hold the motor adjusting bracket to the frame (Fig. 17).
9. Remove the drive belt from the drive pulley (Fig. 18).
10. Slide the motor out of the side frame.
11. Reverse procedure to install

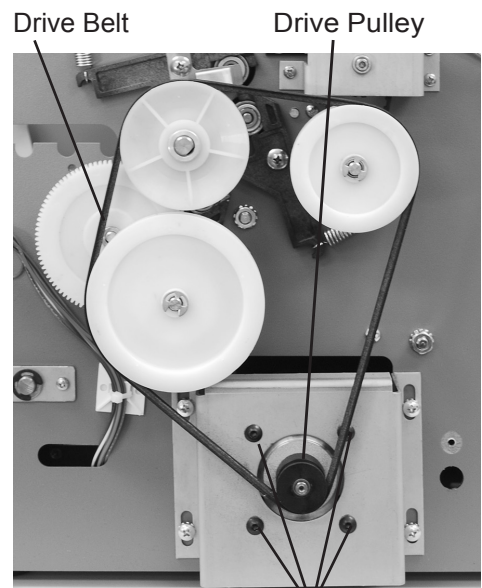

Fig. 18

Mounting screws



## REPLACING SINGULATOR PAD

1. Make sure machine is turned off and unplugged.
2. Open top cover.
3. Loosen center feed tire setscrew with a 5/64" Allen wrench. Slide the tire to one side.
4. Remove the singulator mount assembly (Fig. 19)
5. Peel off the pad (Fig. 19).
5. Clean the singulator mount.
6. Glue a new pad on the mount using an instant glue. Note: Make sure there is no gap between the pad and the front of the singulator mount (Fig. 19)
7. Re-install singulator mount assembly
8. Move the feed tire to its original position, tighten the setscrew and close the cover.

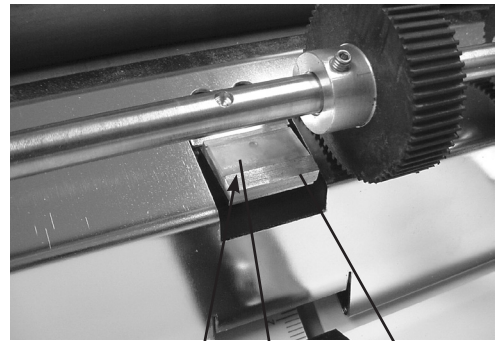

Fig. 19

Singulator Pad Mount Assy.  
Singulator Pad  
Make sure there is no gap.

## REPLACING FEED TABLE SELF-CENTERING SIDE GUIDES

1. Make sure machine is turned off and unplugged.
2. Remove lower fold plate.
3. Loosen side guide locking screws and move guides to the center of the feed tray.
4. Remove the 11/32" nut (Fig. 20) holding the self-centering gear and remove the gear.
5. Unscrew and remove the locking screw.
6. Reverse procedure to install.

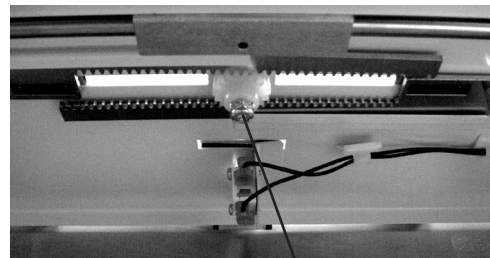

Fig. 20

11/32" Nut

# REPLACING STACKER BELTS

1. Make sure machine is turned off and unplugged.
2. Remove side covers.
3. Remove catch tray assembly.
4. Loosen stacker mounting screws to release tension on belts (Fig. 21a & 21b).
5. Remove one "E" clip from the lower stacker (Fig. 21c) shaft and slide the shaft out of the bushings.
6. Remove the drive belt.
7. Remove large white pulley and smaller white pulley above it from the studs (Fig 21b).
8. Remove the upper conveyor shaft gear (Fig 21b).
9. Remove the "E" clip on the operator side of the upper conveyor drive shaft (Fig. 21a).
10. Remove the "E" clip on the upper conveyor drive shaft (Fig. 21c) on the non-operator side of the
11. Slide the drive shaft toward the non-operator side and remove the brass bushing from non-operator side of the conveyor drive shaft (Fig. 21c).
12. Remove the drive shaft to allow enough clearance to remove the stacker belts.
13. Remove the four screws holding the stacker table in position and remove the stacker table (Fig. 21a & 21c)
14. Reverse procedure to install.

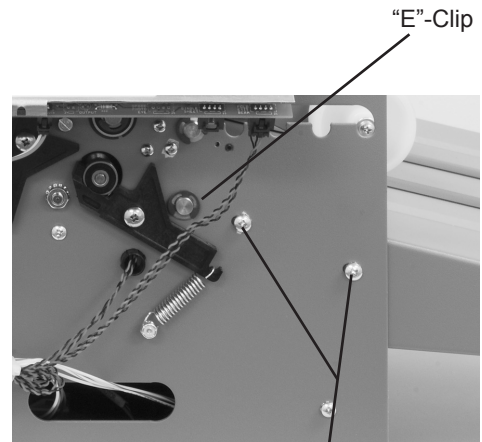

Fig. 21a

Mounting screws

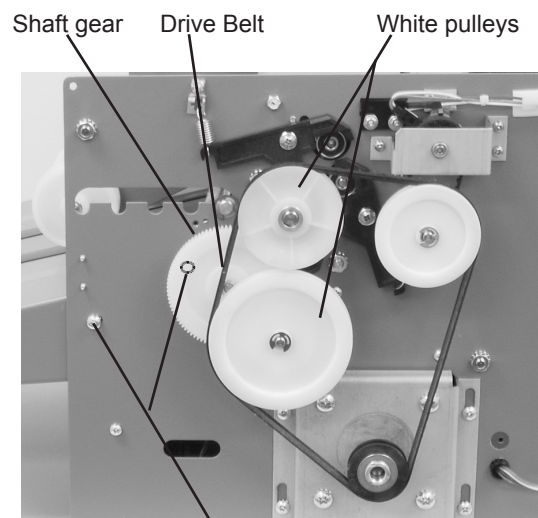

Fig. 21b

Mounting screws

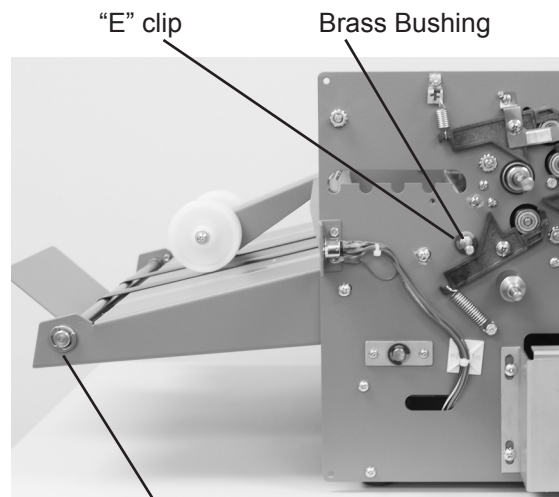

Fig. 21c

Lower stacker "E" clip

# ROLLER SPRING ADJUSTMENT FOR THICK PAPER

## Roller Spring Adjustment:

Thicker paper from 28# up to 65# may require roller spring adjustments.

1. Turn power off and unplug from the wall outlet.
2. Remove both side covers.
3. Remove the control panel from the operator side.
4. Remove the lock nut (Fig. 22a) holding the spring bracket (Fig. 22a) in place.
5. Remove the spring bracket from the screw mount (Fig. 22a) and the spring.
6. Attach the spring directly to the screw mount (Fig. 22b) and replace lock nut.
7. Replace the control panel.
8. Repeat steps 4 - 6 on the non-operator side and replace side covers.

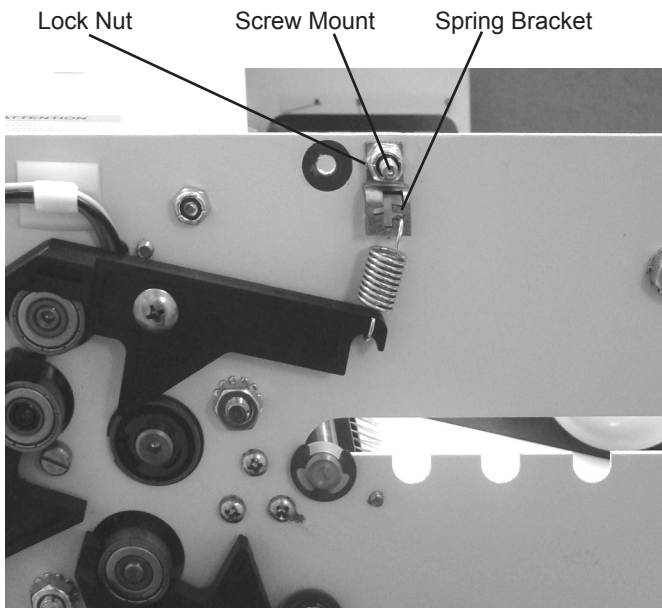

Fig. 22a

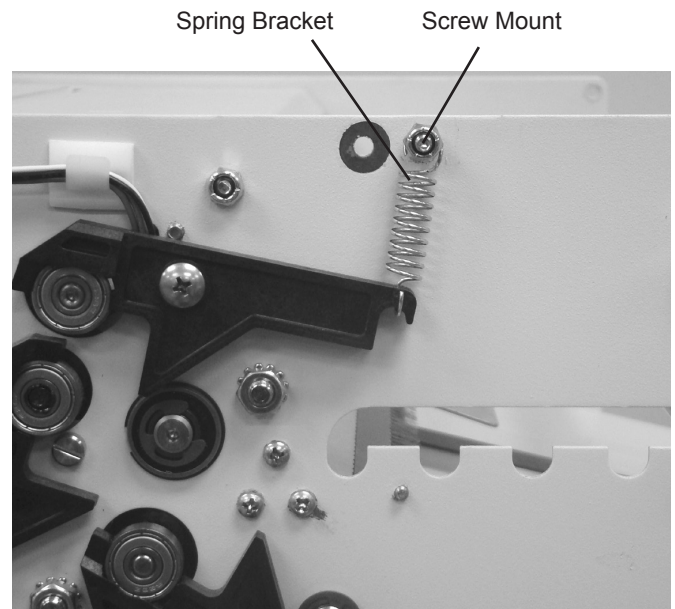







Fig. 22b

# SERVICE MODE

1. To test the motor and clutch operation and check the life count access the service mode. To access start by pressing the AutoBatch “” icon on the home screen (fig. 23a).
2. In the AutoBatch mode insure all windows are set to “0”. (fig. 23b)  
NOTE: If a number is present press the window or the icon to left of the window and reset to zero.
3. Press the number of sets “” icon (it will turn blue when selected (fig. 23c)). Use the keypad to enter “9713” (fig. 23c).
4. Once in the service mode press the “” icon to start the motor. To test the clutch press the “” icon again, while the motor is running to activate. Press “” icon to stop the motor. To exit the service mode press the “” icon (fig 23d).

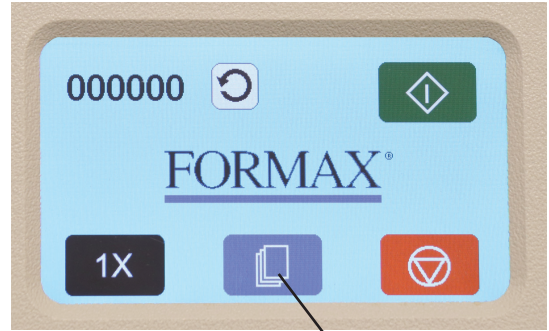

Fig. 23a

AutoBatch Icon

All windows set to “0”

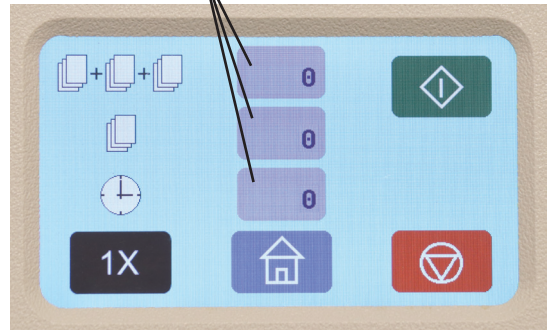

Fig. 23b

Number of sets icon

Enter “9713”

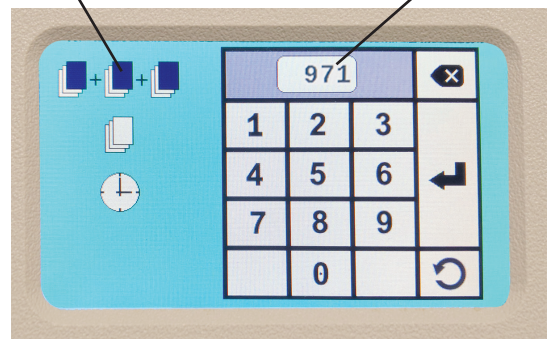

Fig. 23c

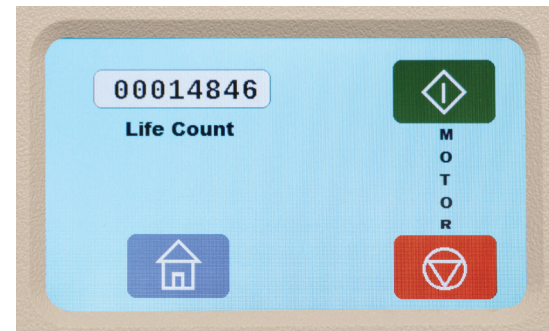
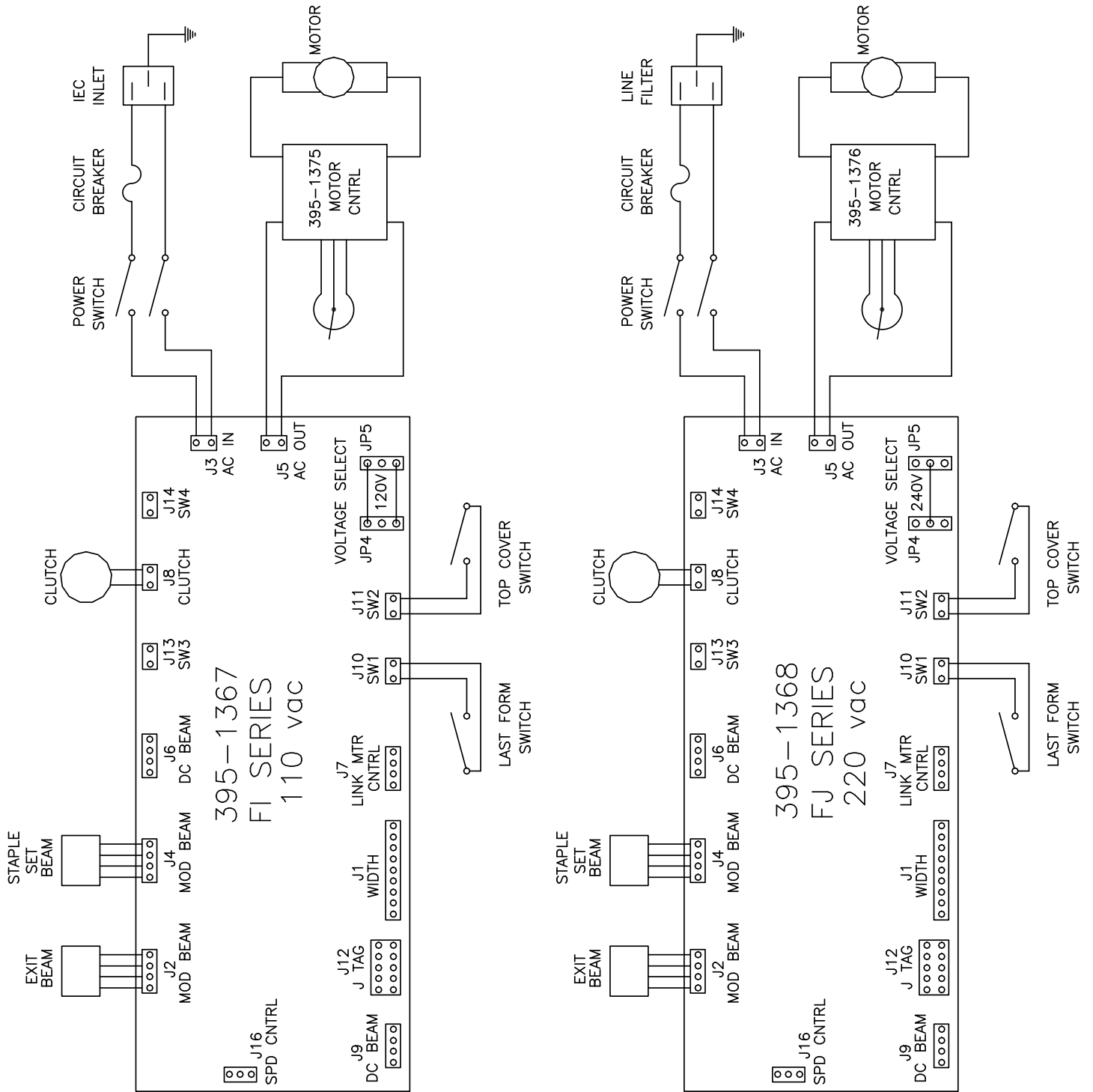
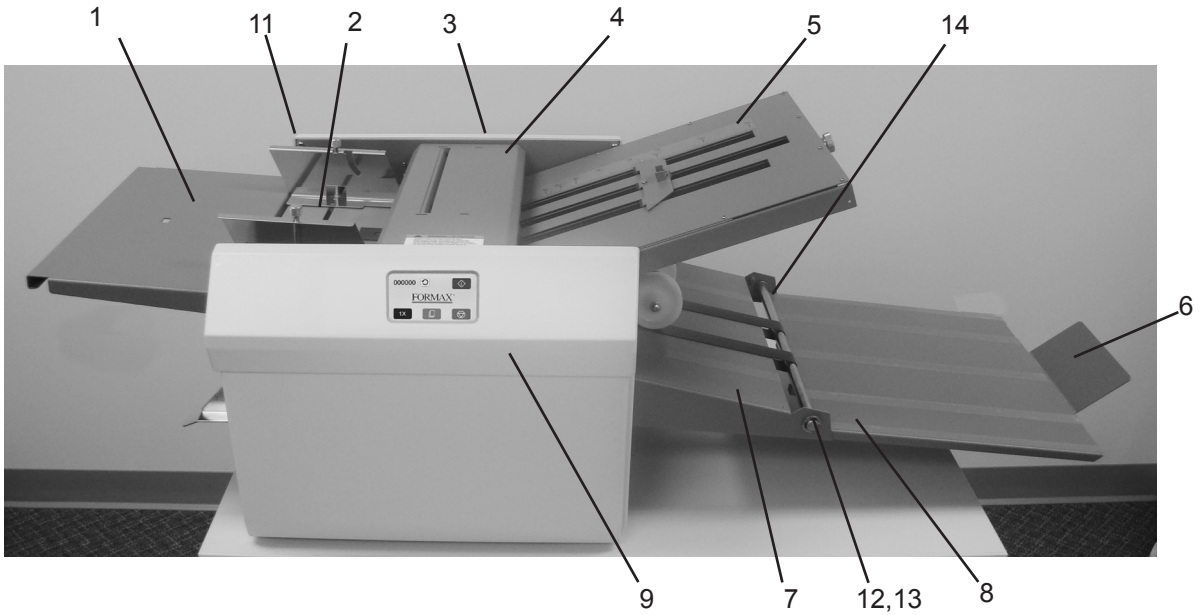

Fig. 23d

# ELECTRICAL SCHEMATIC



# MECHANICAL PARTS



#	QTY	PART #	DESCRIPTION
1	1	360-2648	FEED TRAY EXTENSION
2	1	360-2649	FEED PLATE
3	1	320-0091	REAR COVER
4	1	360-2640	TOP COVER
5	1	395-1212	UPPER FOLD TABLE
NS	1	395-1213	LOWER FOLD TABLE
6	1	395-1192	CONVEYOR TRAY EXTENSION ASSY
7	1	395-1190	CONVEYOR DECK ASSY
8	1	395-1191	CONVEYOR TRAY ASSY
9	1	320-0096	FRONT COVER
10	1	395-0971	CROSS FOLD GUIDE
11	8	373-0133	COVER SCREWS #8-32X3/8" PPH NICKEL
12	2	371-0001	OILITE 1/2 X 5/8 X 3/8 - FLA
13	2	379-0007	E-CLIP RETAINING RING, 1/2 I.D.
14	1	331-0169	CONVEYOR SHAFT

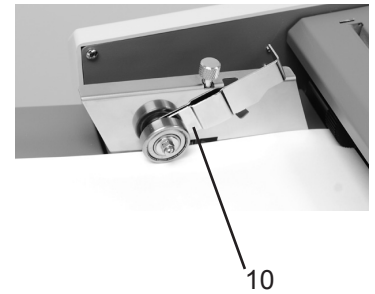

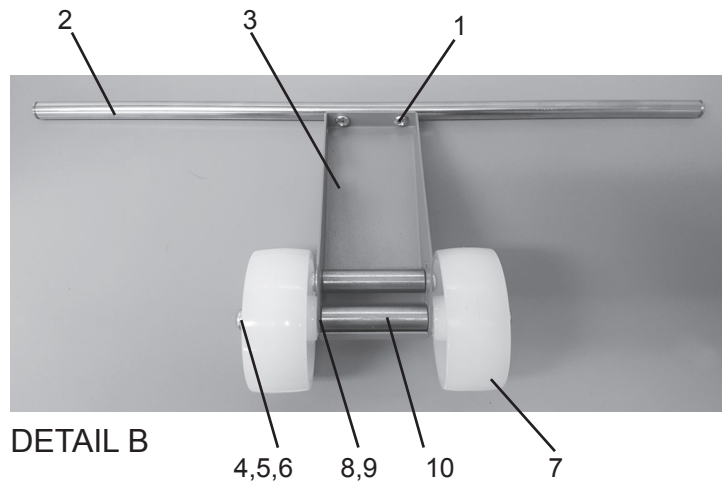
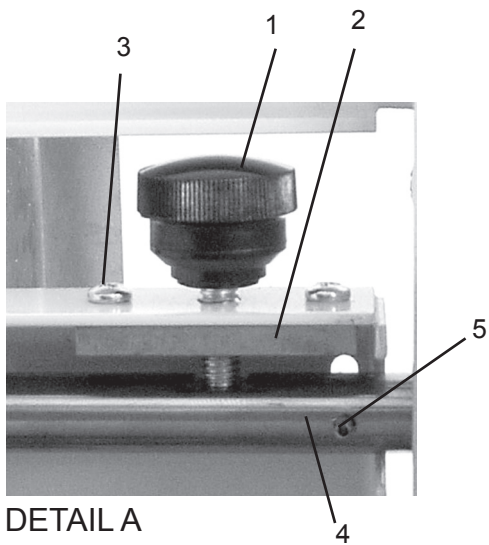
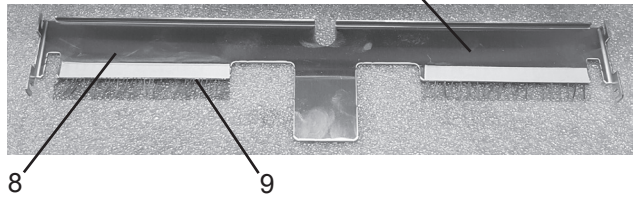
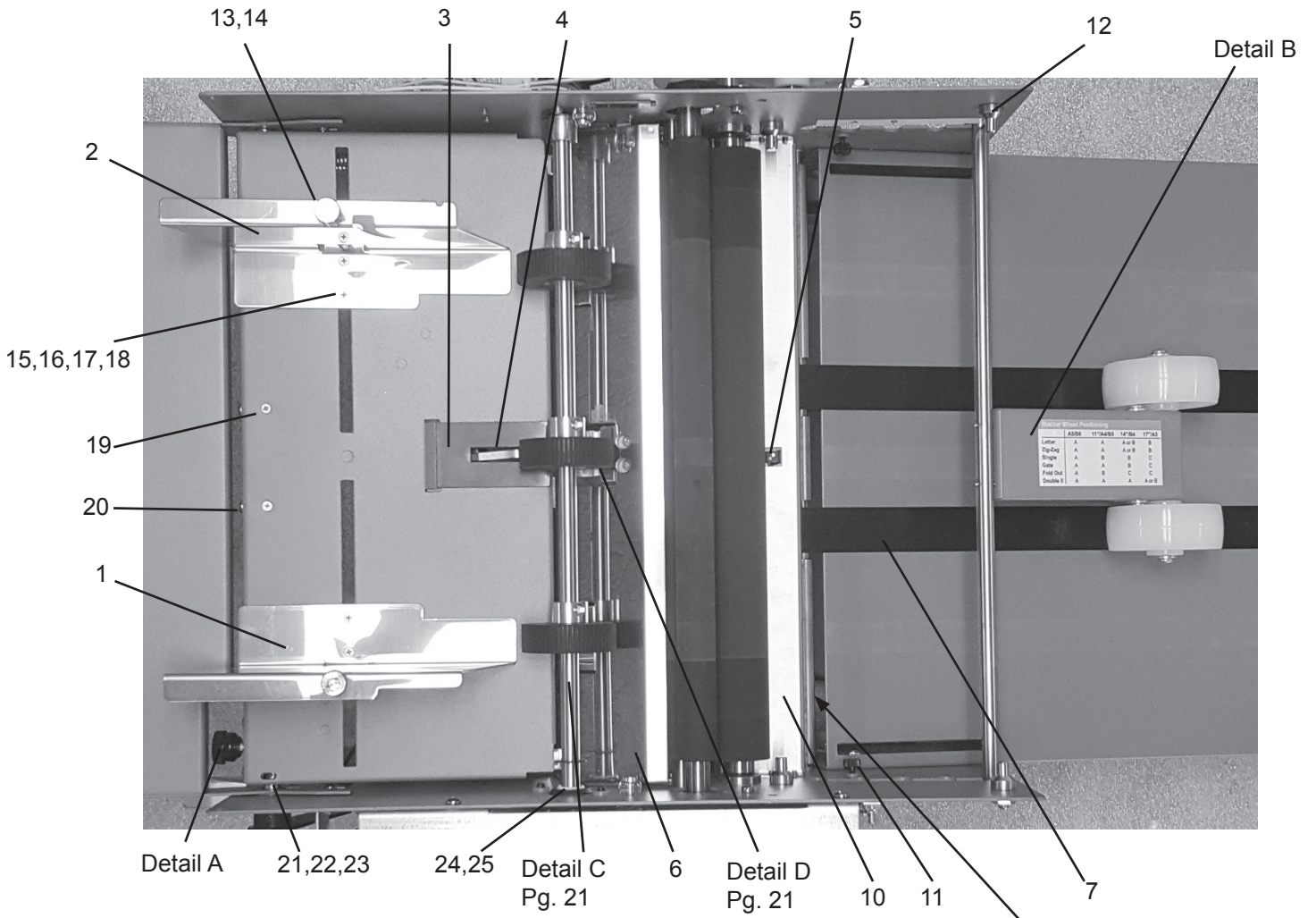

# PAGE 19 DETAIL

#	QTY	PART #	DESCRIPTION
1	1	395-1197	RIGHT SIDE ADJUSTMENT PLATE
2	1	395-1196	LEFT SIDE ADJUSTMENT PLATE
3	1	352-0013	PAD, FEED TRAY
4	1	395-0974	LAST SHEET SWITCH
5	1	310-0134	OUTPUT SENSOR
6	1	360-1959	FEED RAMP
7	2	369-0028	STACKER BELT
8	1	360-2639	EXIT CHUTE
9	2	316-0014	STATIC ELIMINATOR BRUSH
10	1	360-1933	EYE MOUNT CHASSIS
11	2	395-0496	THUMB SCREW, 6-32, FOR EXIT CHUTE
12	8	332-0150	FOLD PLATE PIN
13	2	375-0128	CLAMP SCREW
14	2	377-0097	SPACER
15	4	373-0122	#4-40 FLT HD X 7/16"
16	4	381-0152	STANDOFF, #4 X 3/16" LG
17	4	377-2811	#6 WASHER
18	4	378-0122	4-40 LOCKNUT
19	2	373-0119	#4-40 X 3/16", FLT HD UNDERCUT
20	2	373-0129	#8-32X3/16" PPH SCREW
21	2	371-0013	OILITE 3/8 X 1/2 X 1/4 FLANGED
22	2	377-0075	.380 X 9/16 X .031" NYLON WSHR
23	1	379-0014	E-CLIP FOR 3/8 SHAFT
24	1	371-0101	FEED WHEEL SHAFT, FLANGED BEARING
25	2	375-6538	SCREW 10-32 X 1/2" BUTTON HEAD

## DETAIL A - PAGE 19

#	QTY	PART #	DESCRIPTION
1	1	372-0098	PLASTIC THUMB SCREW, KNURLED
2	1	360-1936	PLATE
3	2	373-0131	#4-40X1/4 PPH SCREW CHROME
4	1	332-0144	PIVOT SHAFT, FEED TRAY
5	1	381-0124	5/64 X 3/4" ROLL PIN

## DETAIL B - PAGE 19

#	QTY	PART #	DESCRIPTION
1	2	373-0129	#8-32X3/16" PPH SCREW
2	1	332-0145	STACKER WHEEL SHAFT
3	1	360-2462	STACK WHEEL ARM
4	2	377-5298	#10 FLAT WASHER
5	2	381-0111	#10 NYLON SPACER 1.25IN
6	2	373-0130	#10-32 X 1 3/4" PPH SCREW
7	2	320-0061	NYLON STACKER WHEELS
8	2	373-0016	SCREW PPH 10-32 x 1/2 LG.
9	2	377-5298	#10 FLAT WASHER
10	2	332-0152	STACKER ARM WEIGHTS



DETAIL C - PAGE 19

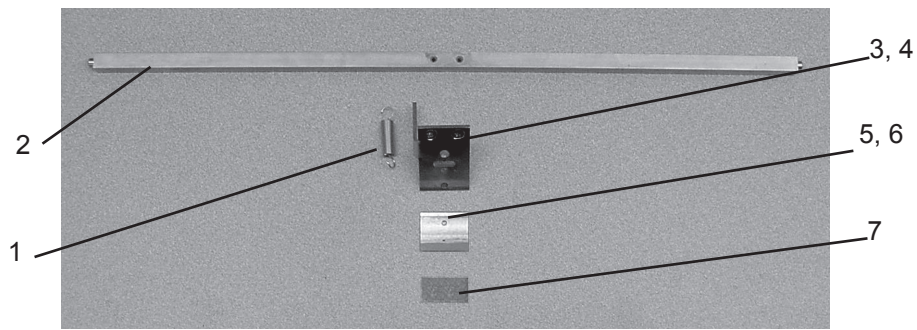

#	QTY	PART #	DESCRIPTION
1	1	342-0092	SPRING EXTENSION 1/4" DIA 1"L
2	1	334-0376	SINGULATOR SHAFT
3	1	360-1930	SINGULATOR MOUNT
4	2	373-0119	4-40 X 1/8" TOP SING. BLOCK SCREW
5	2	373-0126	4-40 X 3/16" BOT. SING. BLOCK SCREW
6	1	334-0377	SINGULATOR BLOCK
7	1	352-0008	SINGULATOR PAD
6 & 7	1	395-1021	SINGULATOR BLOCK AND PAD ASSEMBLY

DETAIL D - PAGE 19

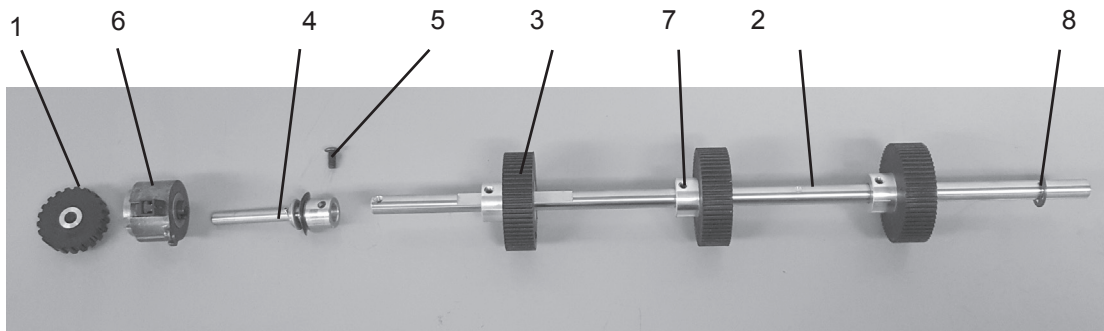
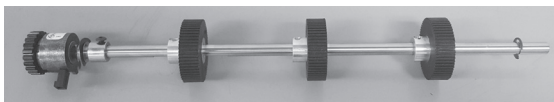

#	QTY	PART #	DESCRIPTION	#	QTY	PART #	DESCRIPTION
1	1	395-0954	21 GROOVE PULLEY, CLUTCH	5	1	375-0014	SCREW, BH #8-32 X 3/8"
2	1	331-0212	FEED SHAFT REMOVABLE	6	1	319-0244	CLUTCH
3	3	350-0099	FEEDER WHEELS, RUBBER 60T	7	3	376-2805	10-32 KNURLED SET SCREW
4	1	395-1193	CLUTCH STUB SHAFT ASSY	8	1	379-0014	E-CLIP FOR 3/8" SHAFT

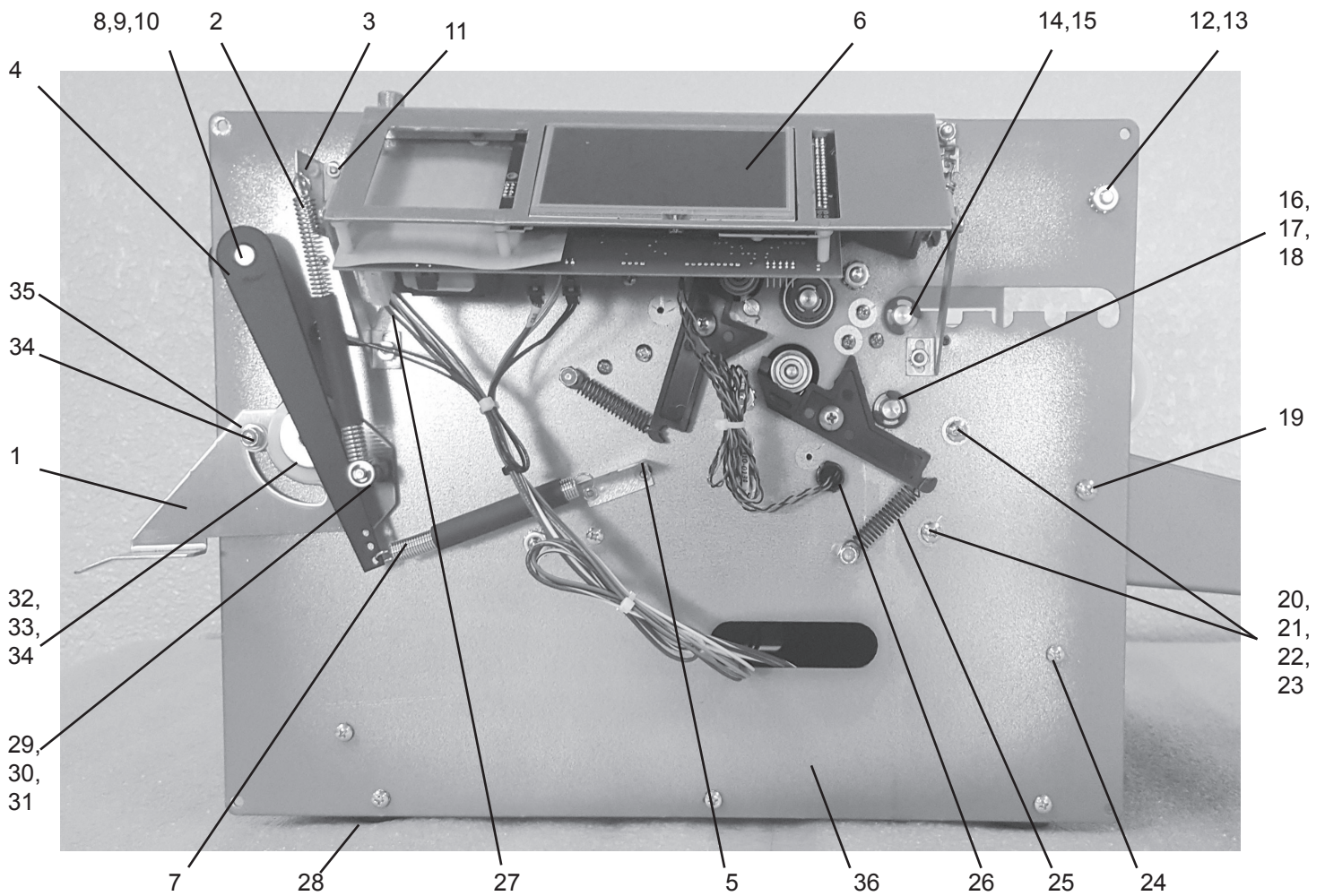

#	QTY	PART #	DESCRIPTION
1	1	360-1938	WELDMENT, LOCK LEVER
2	1	342-0095	SPRING , EXTENSION, 3/8" DIA X 3.5"L
3	1	360-1951	SPRING MOUNT, PAPER FEED
4	1	360-1939	WELDMENT, PAPER TRAY LEVER
5	1	360-1951	SPRING BRACKET, PAPER FEED
6	1	395-1367	CONTROL PANEL ASSEMBLY (110 V)
6	1	395-1368	CONTROL PANEL ASSEMBLY (220 V)
7	1	342-0094	SPRING, EXTENSION, 3/8" DIA X 3.5" I
8	1	381-0123	3/32 X 3/4" ROLL PIN
9	1	377-5481	SPRING WASHER
10	1	377-0081	NYLON WASHER, 3/8 ID X 3/4
11	4	378-0001	4-40 HEX NUT
12	8	332-0150	FOLD PLATE PIN
13	8	378-0132	1/4 28 KEPT NUT
14	2	379-0014	E-CLIP FOR 3/8 SHAFT
15	2	377-0075	.380 X 9/16 X .031" NYLON WSHR
16	1	331-0168	CONVEYOR DR. SHAFT
17	2	371-0013	OILITE 3/8 X 1/2 X 1/4 FLANGED
18	2	379-0014	E-CLIP FOR 3/8 SHAFT

#	QTY	PART #	DESCRIPTION
19	4	373-0124	#10-32 X 1/4" PPH W/EXT LK WSHR
20	2	373-0016	SCREW PPH 10-32 x 1/2 LG.
21	2	377-2809	WASHER #10 EXT STAR
22	1	360-3116	PAPER TRAY STOP
23	2	378-0124	10-32 LOCKNUT
24	10	373-0088	EXT SIN SCREW
25	4	342-0093	SPRING
26	1	315-6584	SNAP BUSHING
27	1	310-0330	MAIN WIRE HARNESS
28	4	372-6544	RUBBER GUIDES
29	1	371-0097	SLEEVE BUSHING
30	2	379-0009	E-CLIP RETAINING RING, 3/16 I.D.
31	1	377-0001	#8 FLAT WASHER
32	1	377-5290	WASHER #10 FENDER
33	2	377-0005	NYLON WASHER
34	2	378-0115	LOCK NUT 8-32
35	2	377-0074	.250 X .500 X .062 NYLON WSHR
36	1	360-2661	OP SIDE (FRONT PLATE)

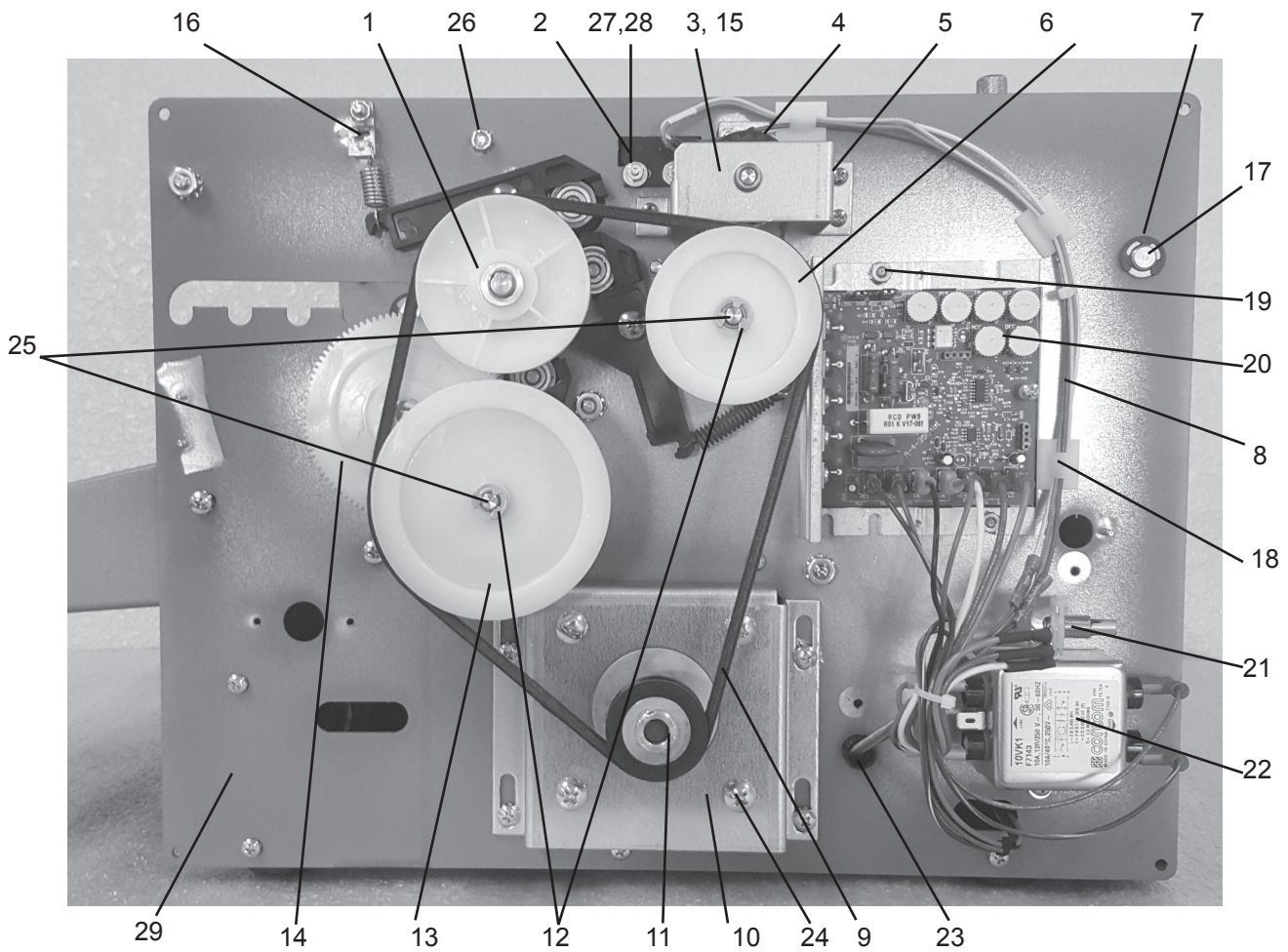

#	QTY	PART #	DESCRIPTION	#	QTY	PART #	DESCRIPTION
1	1	365-0205	PULLEY, 2.4"DIA 1/4 V-SHEAVE	17	1	379-0014	E-CLIP FOR 3/8 SHAFT
2	1	319-0213	MAGNET SENSOR	18	2	315-0019	TIE WRAP MOUNT
3	1	360-2656	CLUTCH BRACKET	19	2	378-9500	6-32 KEP NUT WITH STAR WASHER
4	1	365-0209	TIMING BELT, 38 GROOVE 76XL 1/4"W	20	1	395-1375	SPEED CONTROL (120 VOLT)
5	3	373-5868	SCREW , PPH 6-32 X 1/4" EXT.	-	1	395-1376	SPEED CONTROL (220 VOLT)
6	1	395-1194	FEED REDUCER PULLEY ASSY	21	1	319-0031	SPEED POT
7	2	379-0014	E-CLIP, 3/8" SHAFT	22	1	319-0078	FILTER
8	1	310-0197	CLUTCH WIRE	23	1	315-6584	SNAP BUSHING
9	1	366-0004	V-BELT 14"W X 24"L	24	4	373-5991	SCREW PPH 1/4-20 x 3/8 LG SEMS
10	1	360-1985	MOTOR MOUNT	25	2	331-0211	STUB SHAFT
11	1	366-3171	.9" DIA 1/4" V-SHEAVE (PULLEY)	26	2	378-0115	LOCK NUT 8-32
12	2	379-0033	E-CLIP 1/4" SHAFT	27	2	377-2811	#6 FLAT WASHER
13	1	365-0211	CONVEYOR PULLEY	28	2	378-0001	4-40 HEX NUT
14	1	368-0069	CONVEYOR GEAR 96T, 32P 20PA	29	1	360-2644	DR SIDE (REAR PLATE)
15	1	371-0014	BEARING				
16	2	360-2077	SPRING BRACKET				

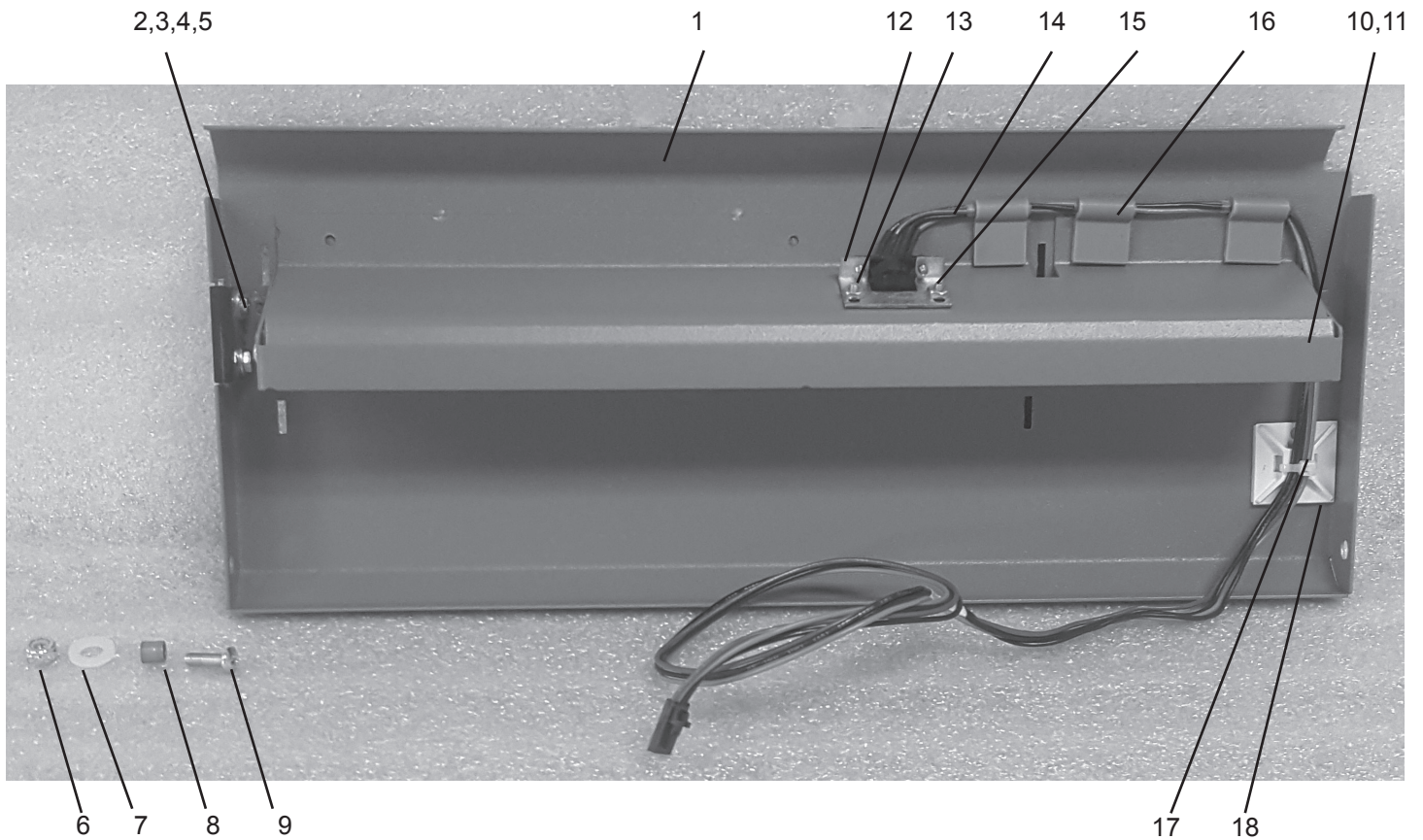

#	QTY	PART #	DESCRIPTION
1	1	360-2640	TOP COVER
2	1	360-1946	SPACER, MAGNET SWITCH
3	1	319-0159	MAGNET ACTUATOR
4	2	377-2811	#6 FLAT WASHER
5	2	378-0001	4-40 NUT
6	2	378-0115	LOCK NUT 8-32
7	2	377-0074	.250 X .500 X .062 NYLON WASHER
8	2	371-0097	3/16X1/4X1/4 SLEEVE BUSHING
9	2	373-0120	8-32 SCREW
PARTS 10 - 18 ARE ONLY REQUIRED FOR THE OPTIONAL MULTI-SHEET FEEDER			
10	1	332-0160	STAPLE SET SHAFT
11	2	373-0129	PH PHILLIPS 8-32 X 1/2"
12	1	360-1941	SWITCH MOUNT
13	2	373-0131	#4-40X1/4 PPH SCREW CHROME
14	1	319-0226	FORM LENGTH HARNESS
15	2	378-0001	4-40 HEX NUT
16	3	315-0054	CABLE MOUNT
17	1	315-5800	TIE WRAP MOUNT
18	1	319-1884	TIE WRAP

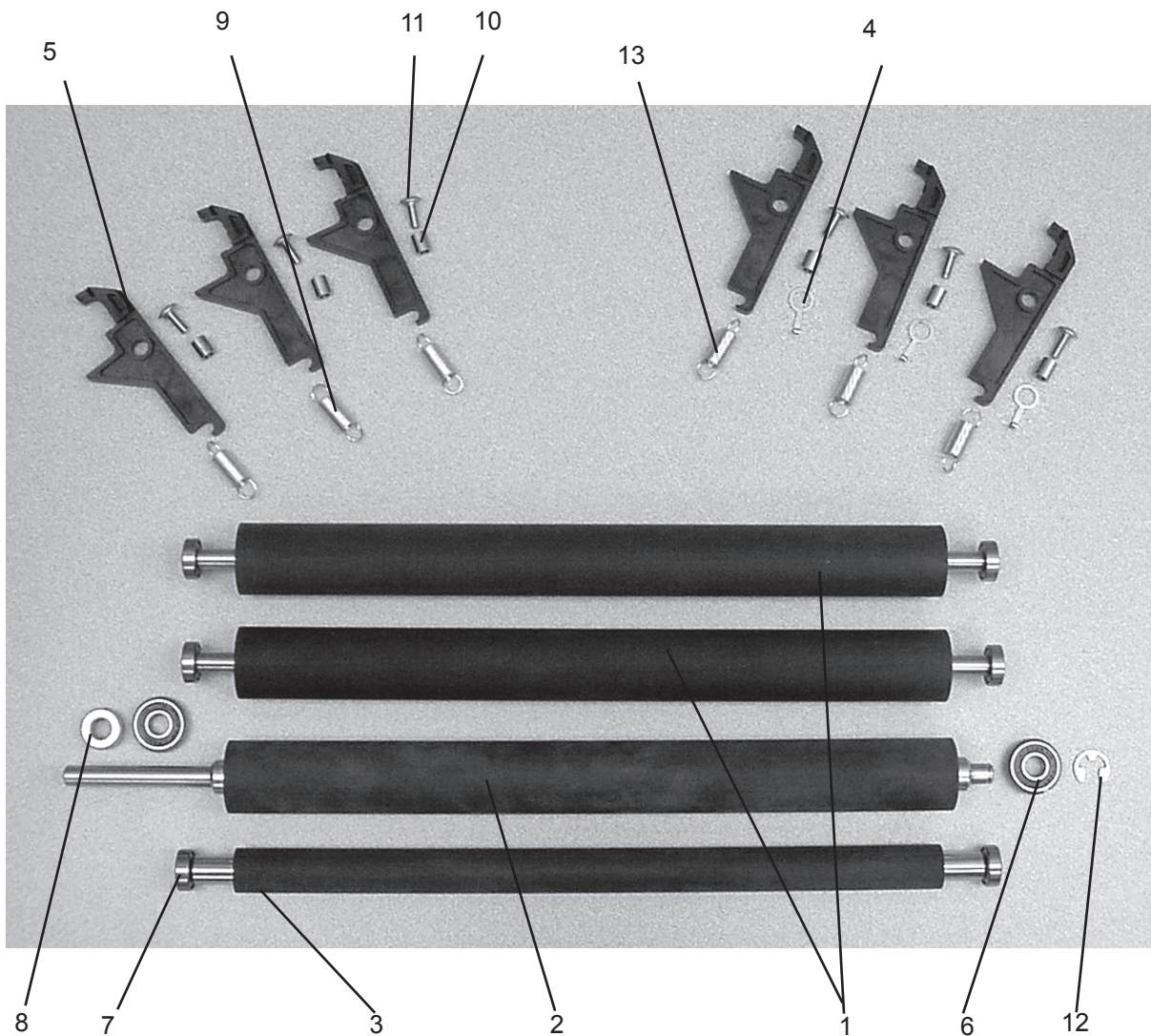

#	QTY	PART #	DESCRIPTION
1	2	395-0959	COMMON ROLLER
2	1	350-0097	DRIVE ROLLER
3	1	395-0958	TOP ROLLER
4	6	360-1988	CLIP, LEVER
5	6	320-0063	MOLDED LEVER
6	2	370-0025	BEARING, BALL W/SNAP RING
7	6	370-0030	BEARING, BALL (INCLUDED IN ITEM #'S 1, 2 & 3)
8	1	330-5730	SHAFT COLLAR
9	4	342-0093	SPRING, EXTENSION - FOR COMMON ROLLERS
10	6	381-0118	SPACER, #10 X 3/8
11	6	373-0121	SCREW, #10-32 X 1/2", TRUSS HEAD
12	1	379-0014	E-CLIP FOR 3/8 SHAFT
13	2	342-0098	SPRING, EXTENSION - FOR TOP ROLLER ONLY

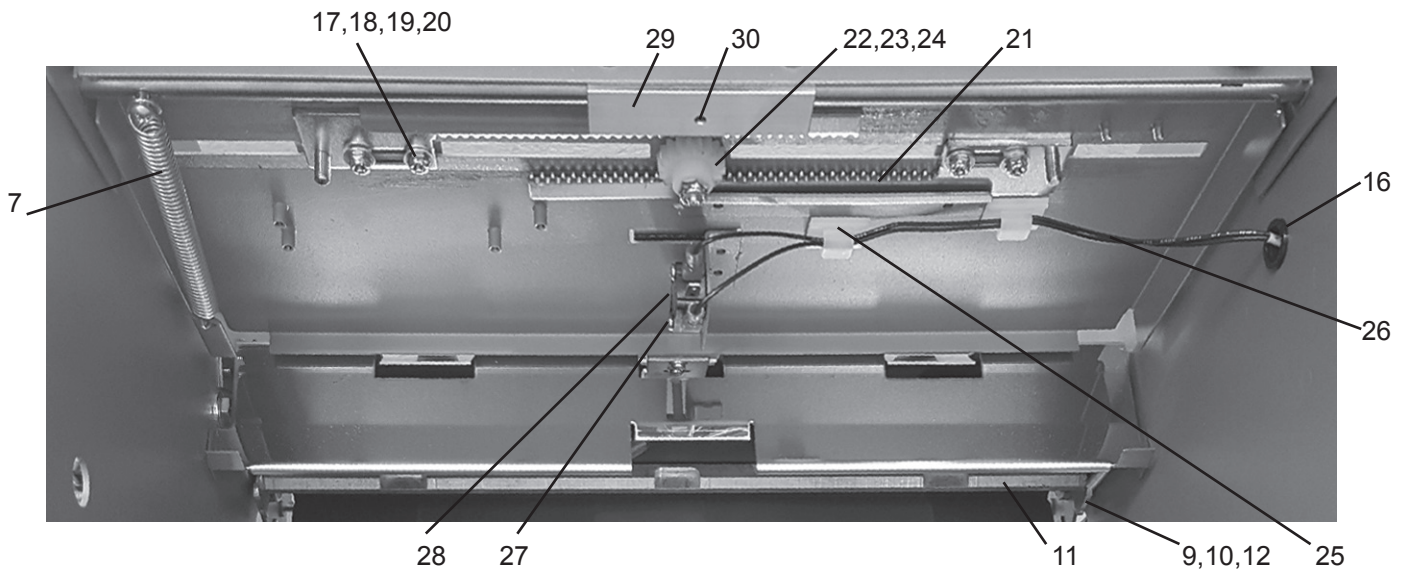
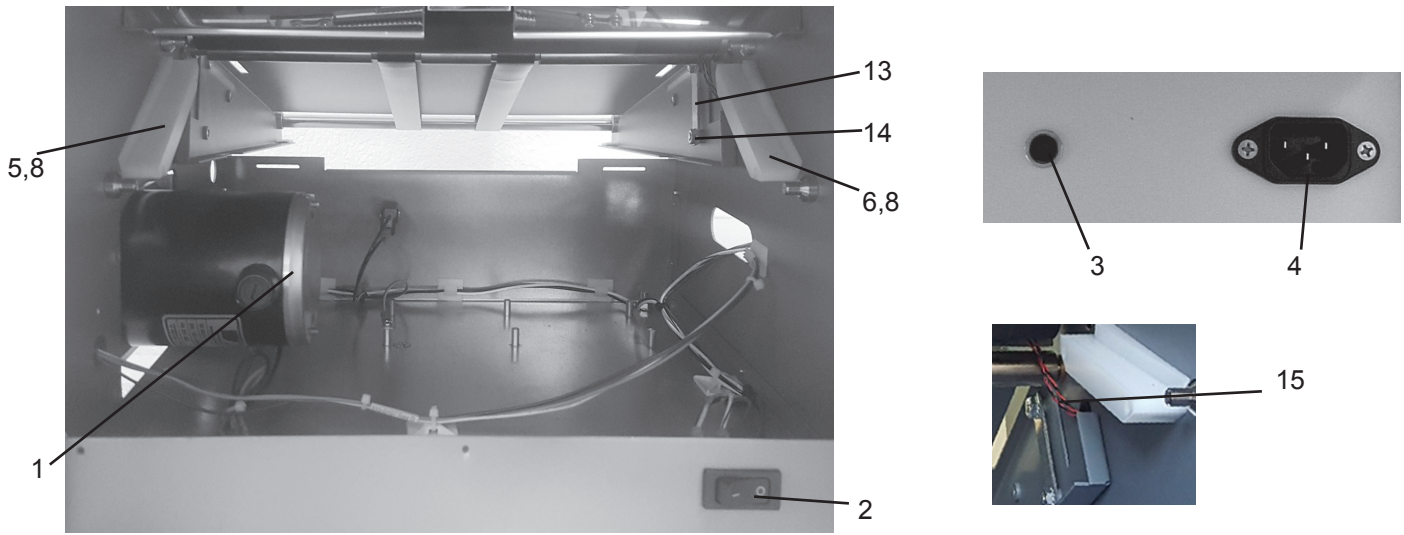

#	QTY	PART #	DESCRIPTION
1	1	313-0053	90V DC MOTOR
2	1	311-0087	POWER SWITCH, DPST, W/QD
3	1	317-0026	BREAKER SWITCH, 2.0 A
4	1	319-0096	AC POWER INLET RECEPTACLE
4	1	395-1214	AC POWER INLET RECEPT. 220V
5	1	320-0069	REAR PLATE GUIDE
6	1	320-0070	FRONT PLATE GUIDE
7	1	342-0096	SPRING
8	4	373-0120	8-32 SCREW FOR #5 & #6
9	1	342-0077	SPRING DIVERTER
10	2	360-1966	END PLATE DIVERTER
11	1	334-0375	DIVERTER
12	4	373-0131	#4-40X1/4 PPH SCREW CHROME
13	1	360-3116	PAPER TRAY STOP
14	2	378-0124	10-32 LOCKNUT
15	1	310-0134	PHOTO EYE HARNESS
16	1	315-6584	SNAP BUSHING

#	QTY	PART #	DESCRIPTION
17	4	373-0122	SCREW #4-40 FLT HD X 7/16"
18	4	381-0152	STANDOFF, #4 X 3/16" LG
19	4	377-2811	#6 FLAT WASHER
20	4	378-0122	4-40 LOCK NUT
21	2	360-1935	CLAMP RACK
22	1	368-0068	NYLON GEAR ASSY, 18 T
23	1	381-0109	#8 NYLON SPACER 1/2IN
24	1	378-0115	SELF LOCK NUT 8-32
25	2	315-0019	CABLE MOUNT
26	1	310-0206	STACK EMPTY CABLE
27	2	373-0019	SCREW PPH 4-40 x 1/2 LG.
28	1	311-0044	LAST FORM SWITCH
29	1	334-0373	PIVOT BLOCK
30	1	381-0120	1/8 X 5/8" ROLL PIN
NS	1	310-0039	POWER CORD
NS	1	310-0224	POWER CORD, EXPORT

# LOWER FOLD TABLE

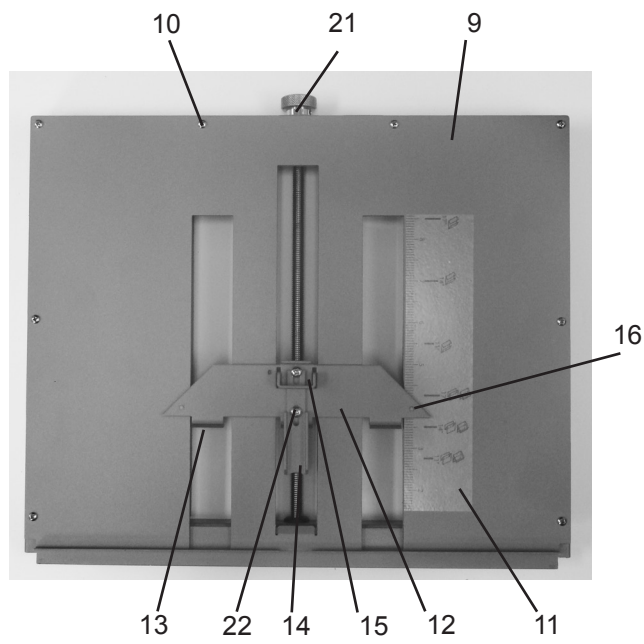
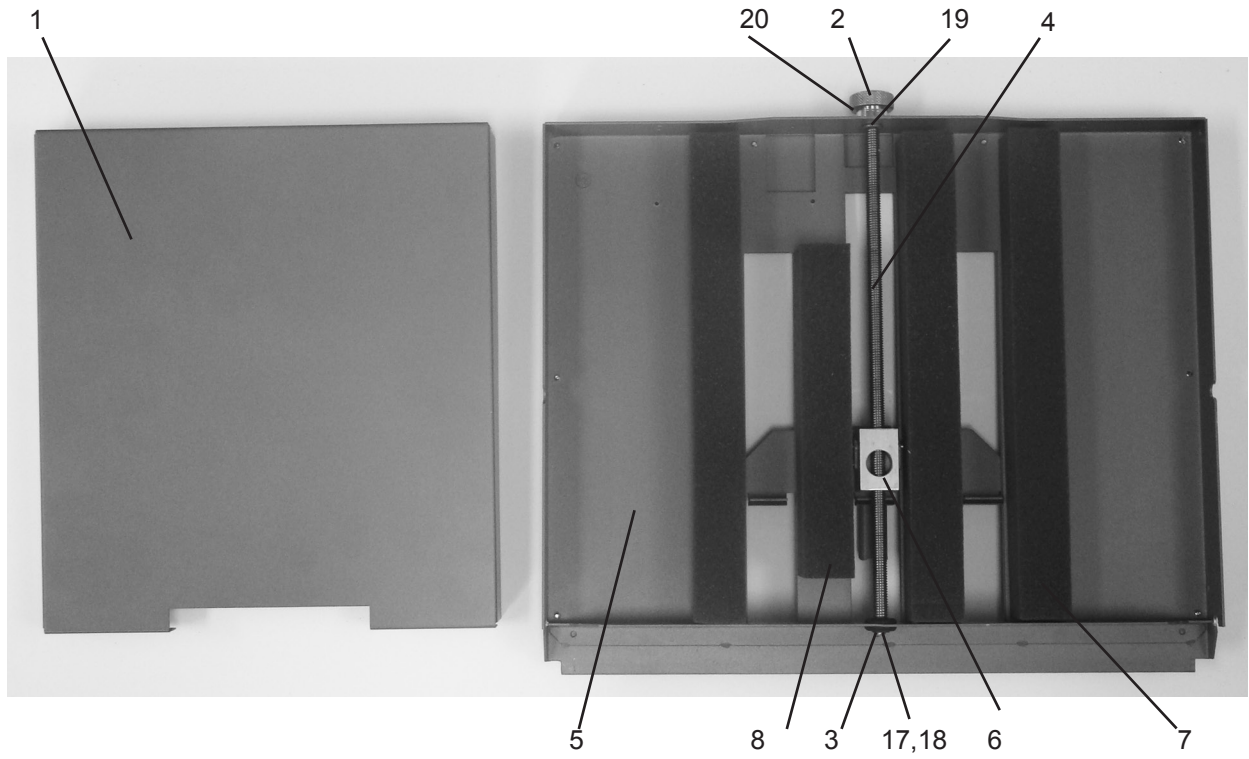

# LOWER FOLD TABLE

#	QTY	PART #	DESCRIPTION
-	1	395-1213	LOWER FOLD TABLE ASSY
1	1	360-2666	WELDMENT, BELLY PAN LOWER TABLE
2	1	334-0378	KNOB, FOLD PLATE ADJUSTMENT
3	1	352-0014	GROMMET FLANGED RUBBER
4	1	331-0171	LEAD SCREW LOWER
5	1	360-2665	WELDMENT, BASE, LOWER PLATE
6	1	395-0962	CAR ASSEMBLY (see note below)
7	3	305-0046	SOUND REDUCTION FOAM 1"X1"X 9.7"L
8	1	305-0048	SOUND REDUCTION FOAM 1"X1"X 6.5"L
9	1	360-2667	TOP SHEET, LOWER FOLD PLATE
10	14	373-0131	#4-40 X 1/4 PPH SCREW CHROME
11	1	325-0488	FOLD PLATE DECAL
11	1	325-0527	RH FOLD PLATE DECAL, EXPORT
	1	325-0528	LH FOLD PLATE DECAL, EXPORT
12	1	360-2664	PAPER STOP
13	3	352-0016	PAD, PAPER STOP
14	1	360-2668	DIVERTER ACTUATOR
15	1	360-2663	RELEASE LEVER FOLLOWER
16	2	381-0114	NYLON RIVET
17	1	371-0093	FLANGED BUSHING
18	1	379-0009	RETAINING RING
19	1	371-0092	FLANGE BUSHING
20	1	377-0072	3/8 NYLON WASHER
21	1	376-0067	SET SCREW 6-32 x 1/4 KNURLED POINT
22	2	373-0132	#6-32X1/4 PPH SCREW CHROME
NS	2	360-2429	SPACER SHORT
NS	2	360-1967	SPACER LONG

NOTE: CAR (395-0962) includes the following parts:

320-0060 HALF NUT  
 342-0091 SPRING  
 381-0121 SPRING  
 371-0096 SLEEVE BUSHING (2 PER)



# UPPER FOLD TABLE

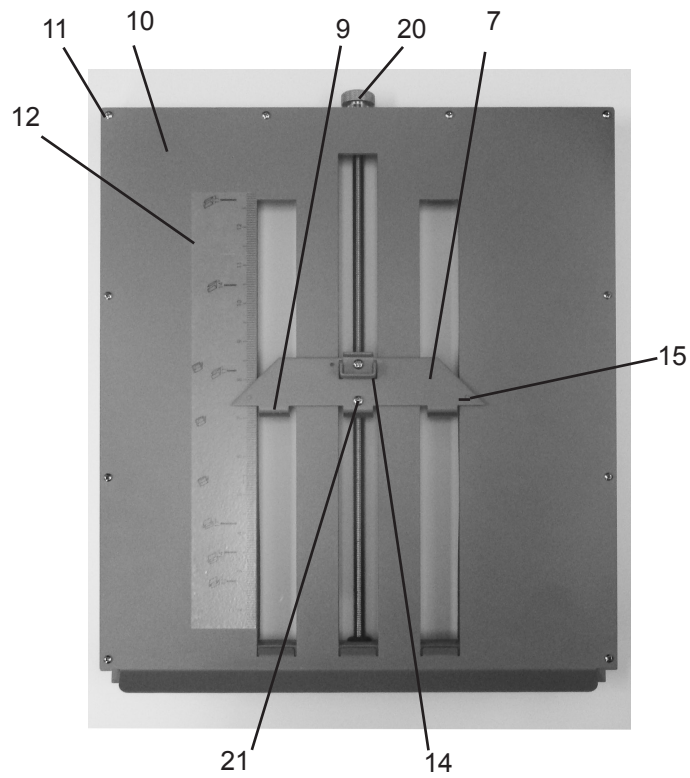
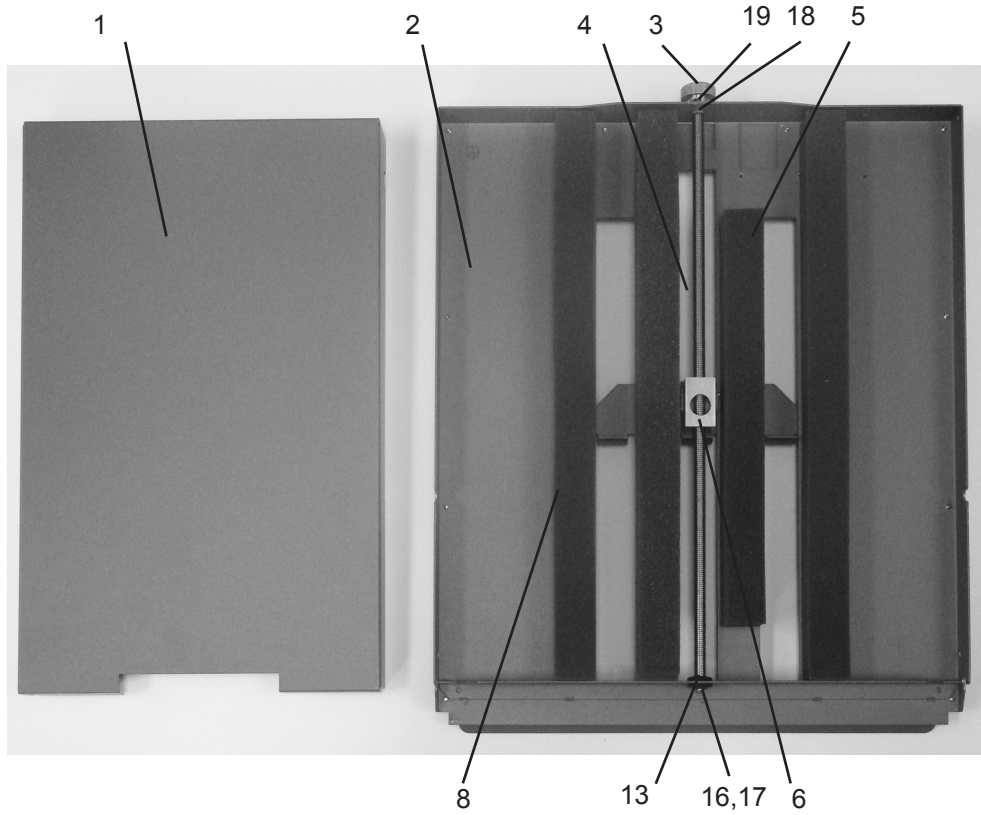

# UPPER FOLD TABLE

#	QTY	PART #	DESCRIPTION
-	1	395-1212	UPPER FOLD PLATE ASSY
1	1	360-2670	WELDMENT, BELLY PAN UPPER PLATE
2	1	360-2669	WELDMENT, BASE, UPPER PLATE
3	1	334-0378	KNOB, FOLD PLATE ADJUSTMENT
4	1	331-0170	LEAD SCREW UPPER
5	1	305-0046	SOUND REDUCTION FOAM 1"X1"X9.7"
6	1	395-0962	CAR ASSEMBLY (see note below)
7	1	360-2664	PAPER STOP
8	3	305-0050	SOUND REDUCTION FOAM 1"X1"X14"
9	3	352-0016	PAD, PAPER STOP
10	1	360-2671	TOP SHEET, UPPER FOLD PLATE
11	14	373-0131	#4-40 X 1/4 PPH SCREW CHROME
12	1	325-0488	FOLD PLATE DECAL
12	1	325-0529	RH FOLD PLATE DECAL, EXPORT
	1	325-0530	LH FOLD PLATE DECAL,EXPORT
13	1	352-0014	GROMMET, FLANGED RUBBER
14	1	360-2663	RELEASE LEVER FOLLOWER
15	2	381-0114	NYLON RIVET
16	1	371-0093	FLANGED BUSHING
17	1	379-0009	RETAINING RING
18	1	371-0092	FLANGE BUSHING
19	1	377-0072	3/8 NYLON WASHER
20	1	376-0067	SET SCREW 6-32 x 1/4 KNURLED POINT
21	2	373-0132	#6-32X1/4 PPH SCREW CHROME
NS	2	360-1961	REAR SPACER, SHORT
NS	2	360-1969	LONG SPACER

NOTE: CAR (395-0962) includes the following parts:  
 320-0060 HALF NUT  
 342-0091 SPRING  
 381-0121 SPRING  
 371-0096 SLEEVE BUSHING (2 PER)

# OPTIONAL MULTI-SHEET FEEDER

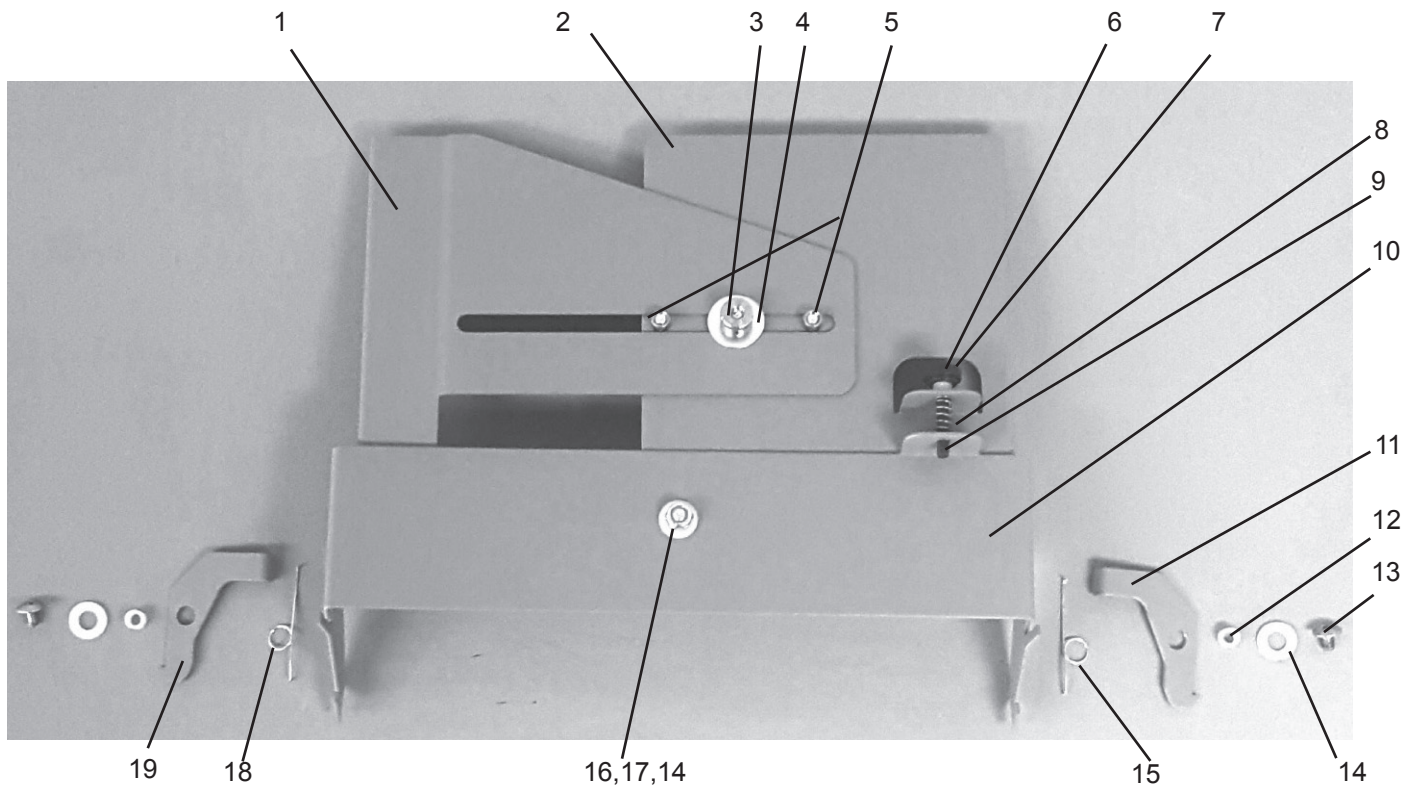

#	QTY	PART #	DESCRIPTION
*	1	395-1203	MULTI-SHEET GUIDE ASSEMBLY
1	1	360-2653	PAPER GLIDE
2	1	360-2654	BACK PLANE
3	1	381-0115	WIDTH ADJUSTER KNOB
4	1	377-0076	#8 FENDER WASHER
5	2	381-0116	1/4" OD X #8 ID X 3/16" ZINC OVER BRASS SPACER
6	1	381-0188	#8-32 THUMB KNOB
7	1	381-0117	NYLON SPACER
8	1	342-0090	1/4 OD x 3/4 length, .02 Music Wire Compression Spring
9	1	374-0093	8-32 x 1" SHCS
10	1	360-2655	YOKE
11	1	360-2652	LATCH (RIGHT)
12	2	381-0125	#8 X 3/16 NYLON SPACER
13	2	373-0134	#8-32 X 1/4" TRUSS HD
14	3	377-0074	WASHER, NYLON 1/4 ID X 1/2 OD
15	1	342-0088	SPRING RH WOUND
16	1	378-0115	8-32 NYLOCK NUT
17	1	381-0117	0.25" OD X #8 ID X 1/8", NYLON SPACER
18	1	342-0089	SPRING LH WOUND
19	1	360-2651	REAR LATCH (LEFT)

**Staple Location**

1

<b>Stacker Wheel Positioning</b>			
	8.5" x 11"	8.5" x 14"	11" x 17"
<b>Letter</b>	A	A or B	B
<b>Zig-Zag</b>	A	A or B	B
<b>Single</b>	B	B	C
<b>Gate</b>	A	B	C
<b>Fold Out</b>	B	C	C
<b>Double II</b>	A	A	A or B



2

#	QTY	PART #	DESCRIPTION
1	1	325-0592	STAPLE SET DECAL
2	1	325-0491	STACKER ARM DECAL

