

FORMAX[®]

AutoSeal[®]

FD 2006/FD 2036

FE 2006/FE 2036

FK/FL Series

MAINTENANCE/PARTS MANUAL
FIRST EDITION

TABLE OF CONTENTS

SUBJECT	PAGE
DESCRIPTION	1
SPECIFICATIONS	1
UNPACKING	2
Components	2
Optional Conveyor Components	2
CONTROL PANELS	3
SETUP	4 - 5
Installing Fold Plates & Power Cord	4
Installing Optional Conveyor	5
OPERATION	6
DETERMING FOLD TYPE	8
SETTING CUSTOM FOLDS	9
OPERATOR MAINTENANCE	10-11
ERROR SCREENS	12
TROUBLE-SHOOTING	13-15
SERVICE MODE	16
MAINTENANCE	13 - 17
ELECTRICAL SCHEMATICS	22-23
PARTS	24-39

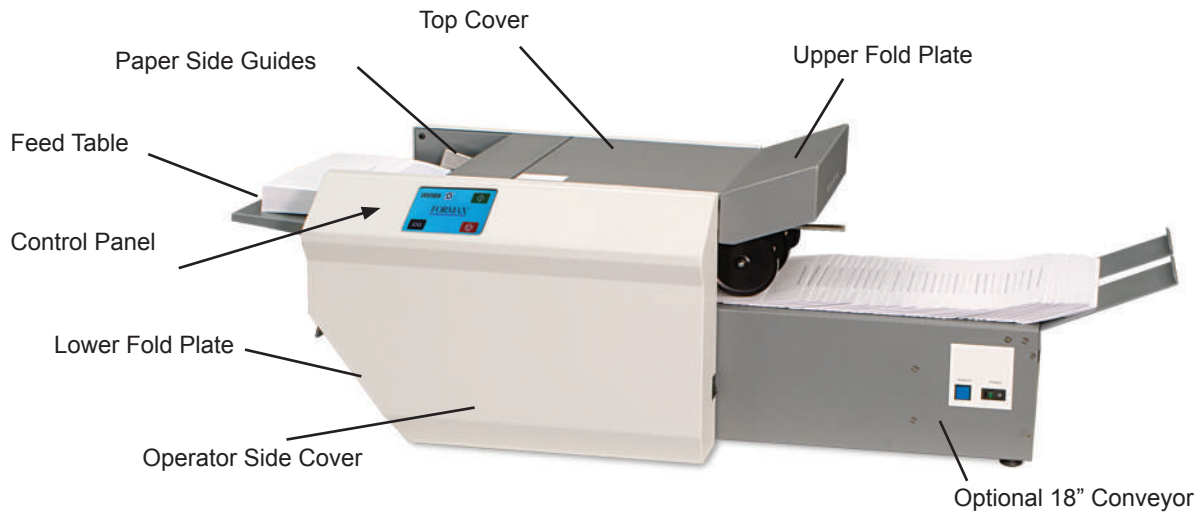

DESCRIPTION



FUNCTION

The pressure sealer folds and seals pressure sensitive forms with pre-applied glue lines into mail ready pieces. Numerous folds using several different paper sizes can be processed to meet your needs. For configurations and paper sizes see specifications.

SPECIFICATIONS

Speed 2006 / 2036:	Standard Mode: Up to 8,000 / 11,000 per hour, depending on fold type
Hopper Capacity 2006/ 2036:	Up to 250 / 350 sheets of 24# (90gsm) pre-glued forms
Paper size:	Min: 3.5" X 5" (88.9 W x 127 L mm) Max: 12.25" X 18" (311 W x 457 L mm)
Pre-Marked fold types:	Letter  , Zig-Zag  , Single 
Pre-Marked Paper Sizes:	FD Model: 11", 14" FE Model: A4
Dimensions: Dimensions w/ Conveyor	25.75" L x 16.5" W x 14.25" H (65 L x 42 W x 36 H cm) 46" L x 22" W x 14.25" H (117 L x 56 W x 36 H cm)
Weight:	90 lbs (40 kg)
Power:	FD Model: 120 volts A.C., 50/60 Hz, 2.5 amps. FE Model: 220 volts A.C., 50/60 Hz, 2.5 amps
Safety Certifications:	UL Approved & CE Applied for

UNPACKING

1. Check package for shipping damage. If there is shipping damage, do not discard the box.
2. Remove the machine and packed components from the box. Upper and lower fold plates, jam Clearing Handle (located under the top cover) and power cord.
CAUTION: Two people must lift the machine from the box.
3. Place the Pressure Sealer on a solid stand.

COMPONENTS

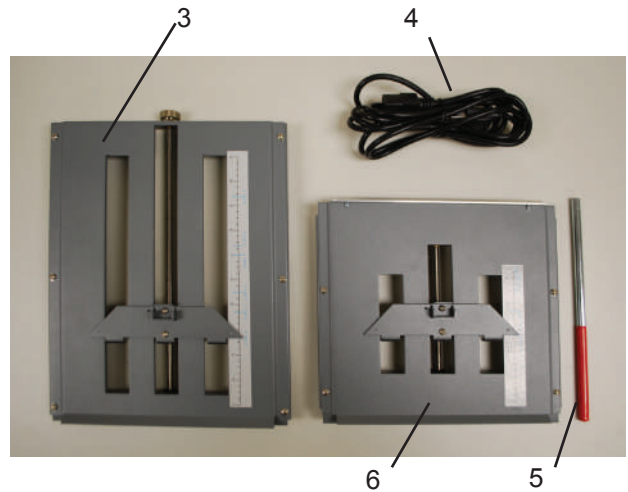

1	2006/2036	4	Power Cord
2	Catch Tray	5	Jam Clearing Tool (ships installed)
3	Upper Fold Plate	6	Lower Fold Plate

OPTIONAL CONVEYOR COMPONENTS

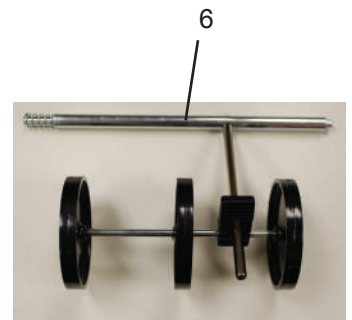
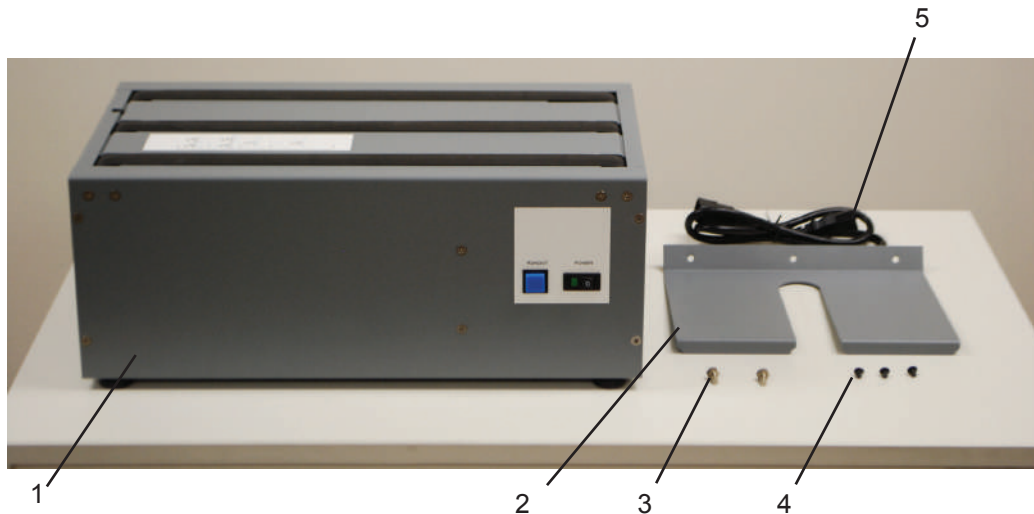

1	Conveyor	4	Extension Tray Mounting Screws
2	Extension Tray	5	Power Cord
3	Mounting Shoulder Bolts	6	Out-feed Wheels

CONTROL PANELS

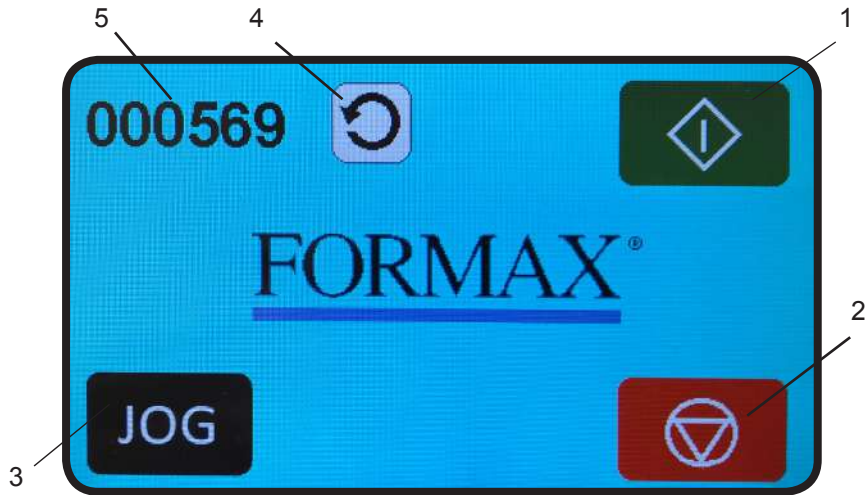

No.	NAME	FUNCTION
1	Start Icon	Press to start
2	Stop Icon	Press to stop / Press
3	Jog Icon	Allows one form to feed at a time. Used to set fold plates
4	Reset Icon	Resets the counter
5	Counter	Shows the number of documents processed

Optional Conveyor Controls

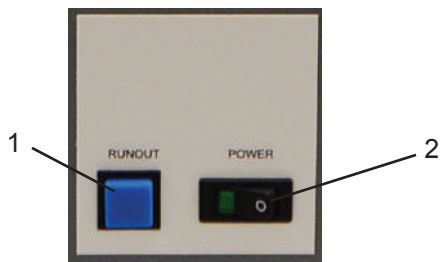

No.	NAME	FUNCTION
1	Runout Button	Advances forms on the conveyor when pushed.
2	Power Button	Turns the power on. When the power is on the green light is illuminates, the conveyor advances using a photo-eye

SETUP

Installing Upper and Lower Fold Plates, and Power Cord

1. Be sure the plate sets firmly on the locating pins (Fig 1a & 1b). Lift the top cover and slide the upper fold plate under the top cover pins onto the fold plate pins. Push down on the fold plate to lock it in position.

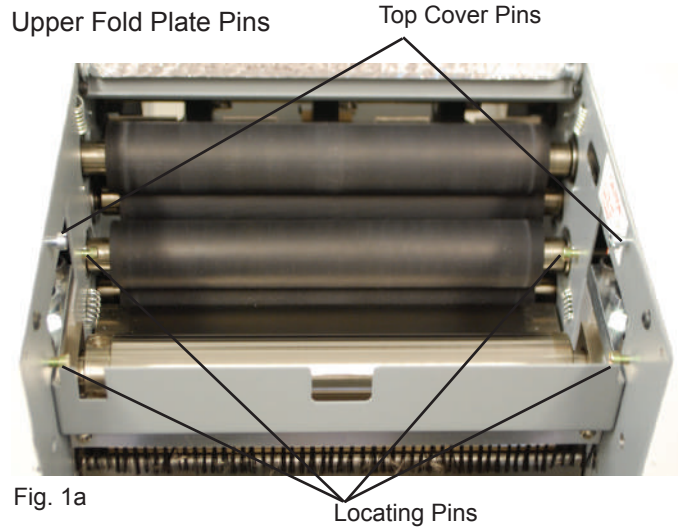

2. Lift the In-feed extension tray and lock it into place. Then slide the bottom fold plate up and in until it meets the rear locating pins then push down to set in place.

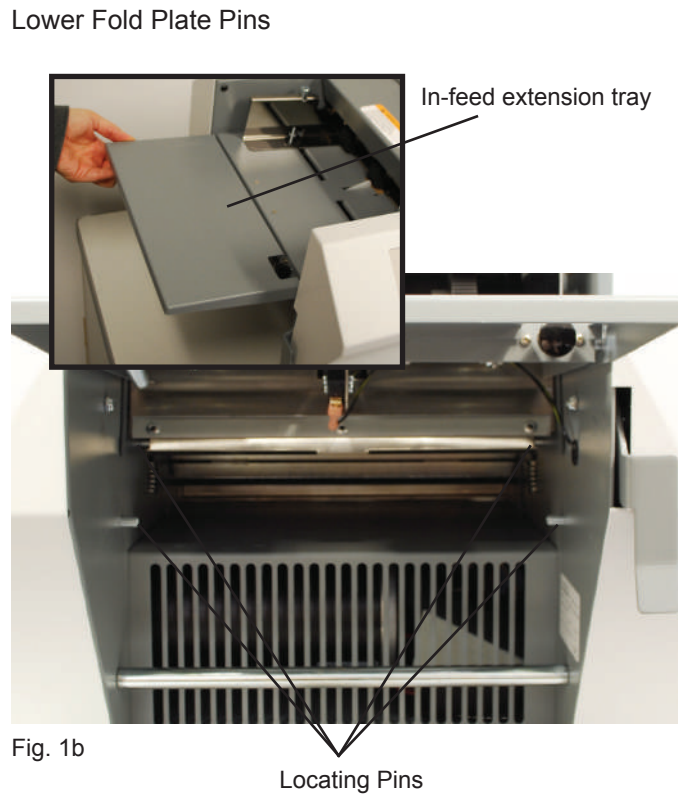

3. Plug the power cord into the left receptacle on the back side of the machine (Fig 1c).



Installing Optional Conveyor

1. Assemble the conveyor. Attach the extension tray to the end of the conveyor using the three extension tray screws (Fig 2a).



Fig. 2a

Mounting Screws

2. Insert power cord to receptacle on the underside of the conveyor (Fig 2b)



Fig. 2b

3. Remove catch tray and install the mounting shoulder bolts into the two screw holes (Fig 2c).



Fig. 2c

Shoulder Screws

4. Open the top cover of the sealer and remove the top fold plate. Then slide the conveyor into position aligning the keyholes on the back of the conveyor with the shoulder screws, slide in and down to lock into position.

5. Install the out-feed nip wheels into the two holes located at the out-feed of the sealer (Fig 2d). Insert the side of the rod with the spring first, push in and then insert the other side. Reinstall the top fold plate and close the top cover.



Fig. 2d

Spring

6. Plug the conveyor into the right receptacle on the back of the 2000 / 2032 (Fig 3).



Fig. 3

OPERATION

1. Place power switch in the “ON” position.
2. After determining the fold type (see pg 6 “Determining Fold Type”) set the Upper and Lower fold plates.

To set the fold stop position, squeeze the fold stop lever and move the fold stop to the desired location on the upper and lower fold plates(Fig 4). Align the pointed part of the stop plate with the desired marks on the decal and release the lever. Fine adjustments can be made with the adjustment knob at the end of the plate (Fig 5).

NOTE: When doing a “Half” fold, remove the bottom fold plate, turn it 180 degrees and insert with the fold deflector leading (Fig 6). The plate must be firmly reinstalled on the locating pins.

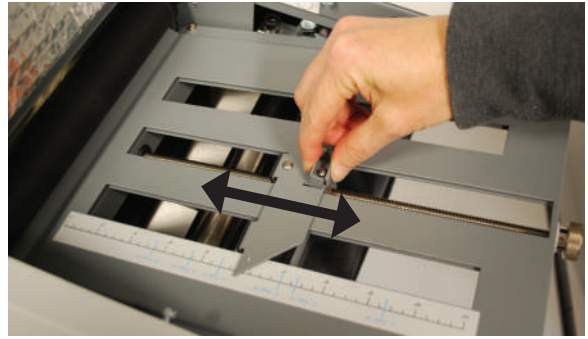

Fig. 4



Fig. 5



Fig. 6

Fold Deflector

- 5a. Set the catch tray (See step 5b if using a conveyor). Slide the catch tray in or out to align the appropriate fold/form setting on the “Fold/form size decal” with the alignment decal located on the non-operator side frame (Fig 7a).
- 5b. Set the conveyor out feed wheels. Align the center of the out-feed stacker wheels with the appropriate fold/ form setting on the “Fold/form size decal” (Fig 7b).



Fig. 7a

Alignment Decal

Fold/Form Size Decal

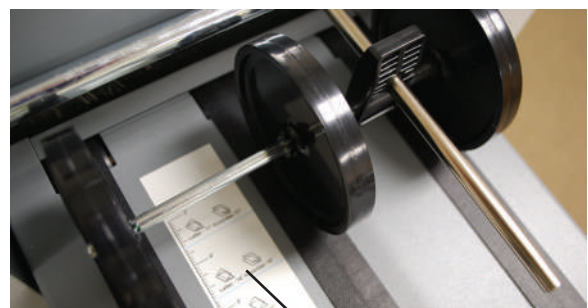

Fig. 7b

Fold/Form Size Decal

5. Set the paper side guides for the forms being used and lock in position (Fig 8a).

Place a form between the side guides. Adjust the side guides by loosening knobs on top, then sliding them toward or away from each other so that the form is snug but still lies flat.

Leave equal spacing between the guides and side frame on both sides to help ensure that the forms feed squarely into the pressure sealer (Fig 8b).

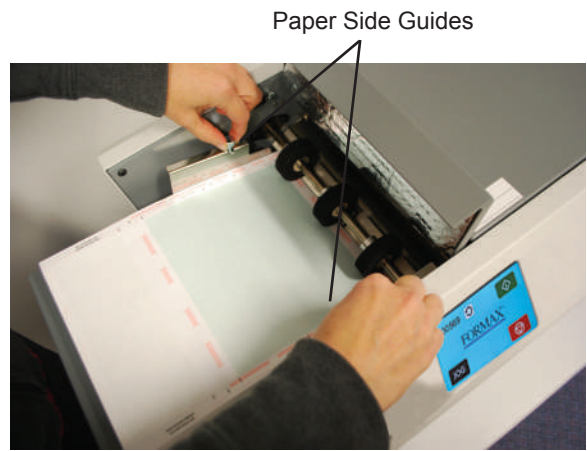

Fig. 8a

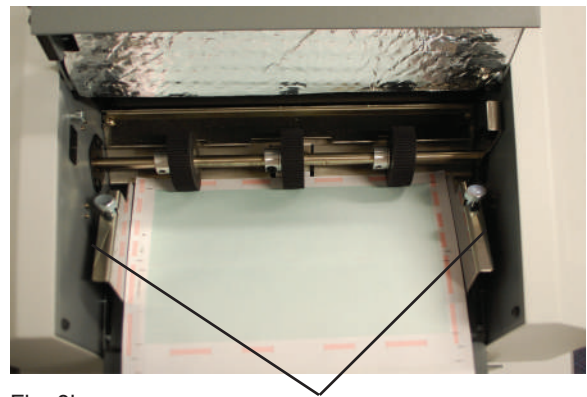

Fig. 8b

Equal spacing between side frame and guides on both sides

6. Lift the in-feed tray lever, then neatly stack paper on the in-feed tray under the feed tires and release the tray lever (Fig 9).

7. Press the “**JOG**” icon on the control panel to test the folds. Adjust as needed.

8. If the fold is skewed use the skew adjustment knob to make corrections (Fig.10).

9. When you're satisfied with the test folds, press the “” icon to operate the machine.



Fig. 9

In-feed Tray Lever

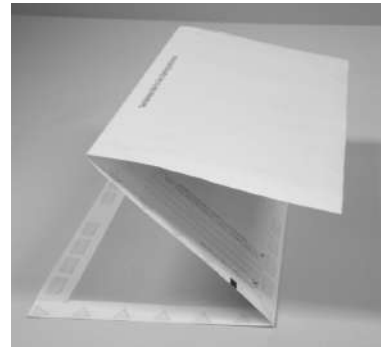
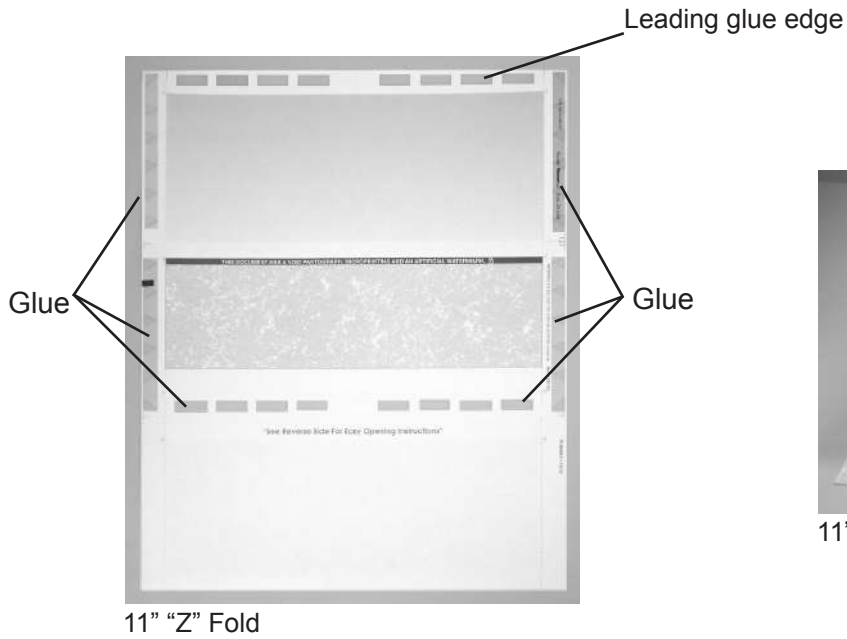

Fig. 10

Skew Adjuster

DETERMINING FOLD TYPE

Two Standard Folds 11" "Z" & 11" "C"



11" "Z" Fold

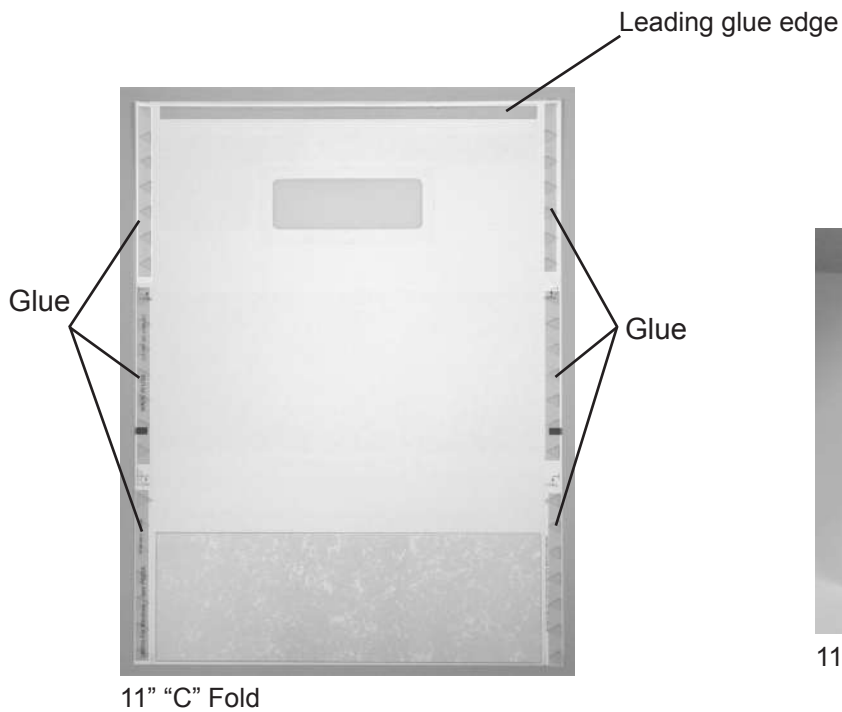

11" "C" Fold

SETTING CUSTOM FOLDS

Example 1: Uneven “Z”

1. Measure the length of panel “A”
2. Adjust the upper fold plate so that the fold stop lines up with the measurements of the panel “A” i.e. if panel “A” is 5 1/4” long slide the stop plate up or down so that it lines up with the 5 1/4” mark on the fold plate.
3. Measure the length of panel “B”
4. Adjust the lower fold plate so that the stop plate lines up with the measurement of panel “B”
5. Load forms and press test. If folds are too long or too short adjust accordingly.

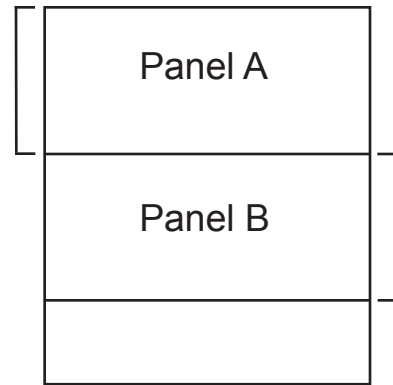

Example 2: Uneven “C”

1. Measure the length of panel “A” & “B”
2. Adjust the upper fold plate so that the fold stop lines up with the measurements of panel “A” & “B”. i.e. if panel “A” & “B” are 10 1/2” long slide the stop plate up or down so that it lines up with the 10 1/2” mark on the fold plate.
3. Measure the length of panel “B”
4. Adjust the lower fold plate so that the stop plate lines up with the measurement of panel “B”
5. Load forms and press test. If folds are too long or too short adjust accordingly.

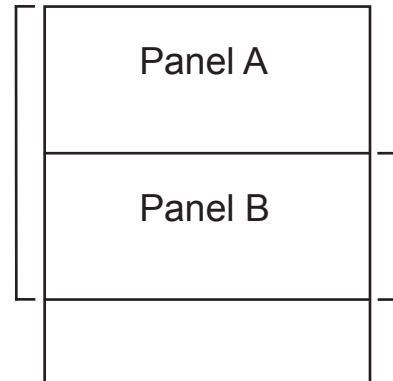

OPERATOR MAINTENANCE

1. It is recommended to let forms cool for one-half hour, from the laser printer, before folding. This allows toner to set on the forms and static electricity to discharge. A 402 Series Jogger is recommended for best results. The Jogger squares the forms and dissipates heat and static electricity created by laser printers.
2. If toner builds up on the metal sealer rollers clean the rollers with a lint-free cloth dampened sparingly with a mild household cleaner.
3. Clean in-feed tires and fold rollers with Formax recommended roller cleaner & rejuvenator to remove paper dust and toner. A Formax Cleaner Kit is available from your dealer. A damp cloth with water is the best alternative.

CAUTION: Do not use any chemicals other than the roller cleaner & rejuvenator or water.

METAL SEAL ROLLERS CLEANING PROCEDURE:

1. Make sure machine is turned off and unplugged. All folders have four (4) rubber rollers (Fig. 11).
2. Open the top cover and remove the upper fold plate to access the seal rollers.
3. Using a mild household cleaner, spray a new cotton cloth until the cloth is saturated. Wipe the wet cloth in a back and forth motion and rotate the rollers by hand making sure to clean the entire surface of the seal rollers. Next use a dry cloth and wipe off excess toner. The cloth should be covered with black toner surplus from cleaning the rollers.
4. Run 10-15 sheets of blank copy paper through the folder/sealer to ensure all cleaner has been removed from the fold rollers. Running blank sheets will remove any excess residue of cleaner on the rollers.

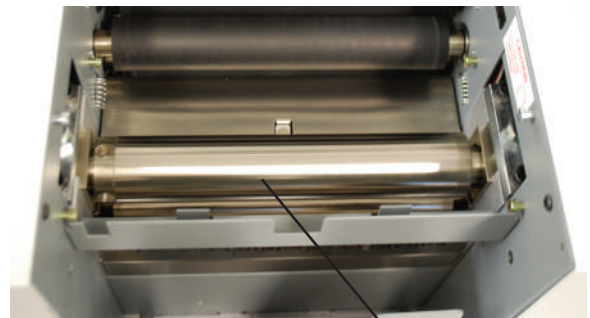

Fig. 11

Seal Rollers

IN-FEED TIRES AND FOLD ROLLERS CLEANING PROCEDURE:

1. Make sure machine is turned off and unplugged. The sealers have three (3) feed tires and four (4) rubber rollers (Fig. 12a & 12b).
2. Open the top covers and remove the upper and lower fold plates to access the tires and rollers.
3. Using Formax roller cleaner, spray a new cotton cloth until the cloth is saturated. Wipe the wet cloth in a back and forth motion and rotate the tires / rollers by hand making sure to clean the entire surface of the feed tire / fold rollers. Next use a dry cloth and wipe off excess toner. The cloth should be covered with black toner surplus from cleaning the tires / rollers.
4. Run 10-15 sheets of blank copy paper through the folder/sealer to ensure all cleaner has been removed from the fold rollers. Running blank sheets will remove any excess residue of cleaner on the rollers.

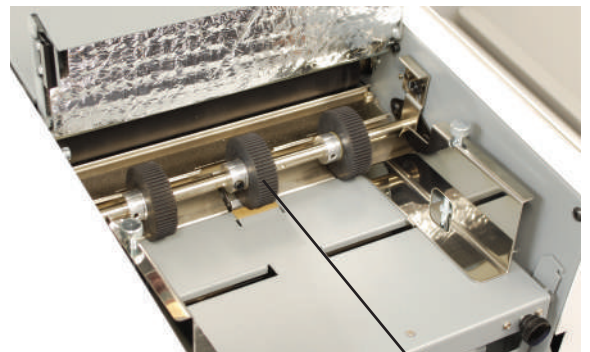

Fig. 12a

Feed Tires

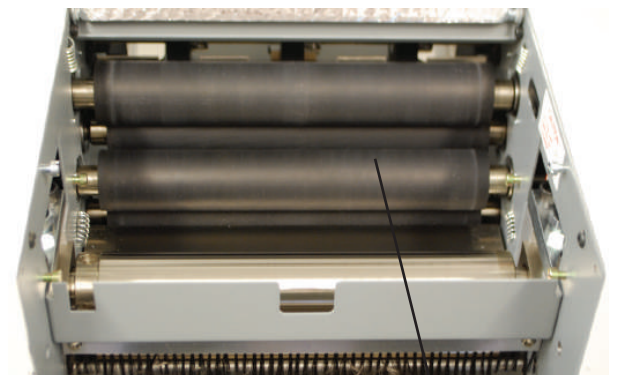

Fig. 12b

Fold Rollers

CLEARING PAPER JAMS:

WARNING: Turn off machine and unplug cord from its receptacle

1. If a jam occurs between the metal rollers remove any remaining forms from the hopper. Open the top cover and remove the upper fold plate. Remove the jam clearing handle (located under the upper fold table) apply the handle to the upper metal roller (Fig13) and turn clockwise until the paper jam is clear. NOTE: Do not turn the roller counter-clockwise to force the forms to exit: rollers may be damaged. Remove the damaged form, return tool to holder and reinstall upper fold plate.

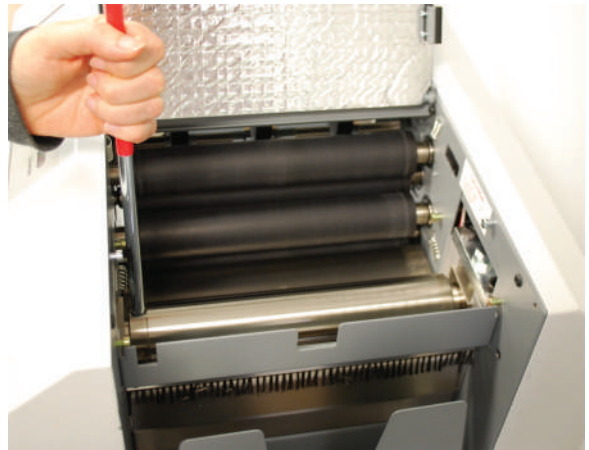

Fig. 13

2. Reinstall cover and press the black reset button (Fig14).

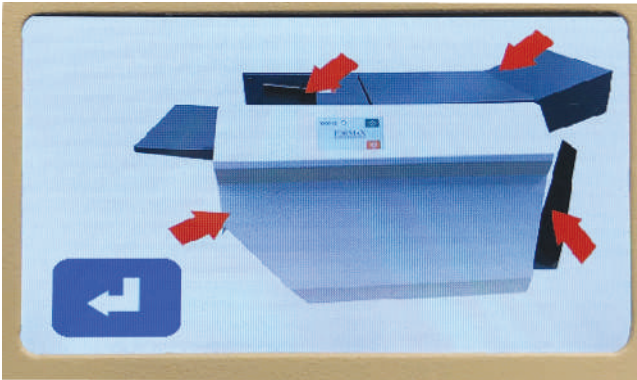



Fig. 14

Reset Button

ERROR SCREENS

Paper Out / Paper Mis-Feed / Paper Jam



1. The feeder is empty. Load paper paper into the feeder and press the “” icon to resume operation.

2. A mis-feed has occurred. Reset the stack of paper in the in-feed and press the “” icon to resume operation.

3. A Paper jam has occurred in one of the areas indicated. Turn the folder to the off position and unplug. Check the area indicated for paper and remove. Replace the fold plates and plug the folder in and the power on.

Cover Open



The top cover is open. Close the top cover and press the “” icon to resume operation.

TROUBLESHOOTING

TROUBLE	POSSIBLE CAUSE	REMEDY
Control panel lights are not illuminated.	No power at the wall outlet.	Check wall outlet.
	No power to the machine inlet.	Check power cord for frayed/broken wires.
	No power to the control panel.	Press the button on the circuit breaker.
	Internal electrical failure	Call for service
"Cover Open" screen displayed	Cover open	Close cover
	Magnetic switch is broken.	Call for service
"Paper Out " screen displayed	In-feed tray is empty.	Place documents on the in-feed tray.
"Fault detect" screen displayed.	Paper misfeed	Reload paper and press "Reset".
	Paper jammed at exit of folder.	Remove paper and press "Reset".
Black marks on the folded paper.	In-feed tires, separator, fold rollers and/or sealer rollers are dirty.	Clean the parts with approved roller cleaner and rejuvenator.
Folds are off.	Fold plate(s) need to be adjusted	Adjust fold stop and or fine tuning knob
Fold is skewed.	In-feed tray is out of adjustment.	Turn skew adjuster knob to remove the skew.
	Paper side guides need to be reset.	Loosen side guides rest and lock into position, side guides should be evenly balanced
Documents are wrinkled or crunched.	Fold plates are not inserted correctly.	Remove and reinstall fold plates. Be sure they're properly positioned.
	Piece of paper or other material is stuck in the fold plate.	Remove object from the fold plate.
In-feed tray lever does not work	Broken spring	Call for service
Double feeding forms	Documents stuck together	Jog forms to remove static electricity.
	Feed tire or separator worn	Call for service
Not feeding documents	Feed tire dirty	Clean feed tire
	Feed tire or separator worn	Call for service

TROUBLESHOOTING

A. Fold Quality Needs Improving:

1. Make sure paper is squared and installed correctly. Side guides should be evenly balanced and snug against the paper.
2. If folds are still incorrect adjust fold plates (see fold plate adjustment on page 3).

B. Fold Quality Is Still Incorrect: Adjust Fold.

1. Take a piece of plain copy paper; mark the leading edge, (first edge of paper to feed into machine).
2. Run the paper through the machine.
3. Place a pressure seal form on the top cover of machine.
4. Place the piece of plain paper, just processed, on top of the pressure seal form aligning the leading edge of both forms (see diagram below).
5. Check to see if folds on the plain paper line up with the fold perforations of the pressure seal form (see figure 8, below). If the folds on the plain paper & fold perforations on the pressure seal forms do not line up, adjust the fold plates (see fold plate adjustment on page 3).
6. Once the adjustments have been made, take one pressure seal form and test it.
7. Tear open processed form and inspect to see if folds line up with the fold perforations.

NOTE: Repeat this process until the folds on plain paper line up with the perforations on the form.

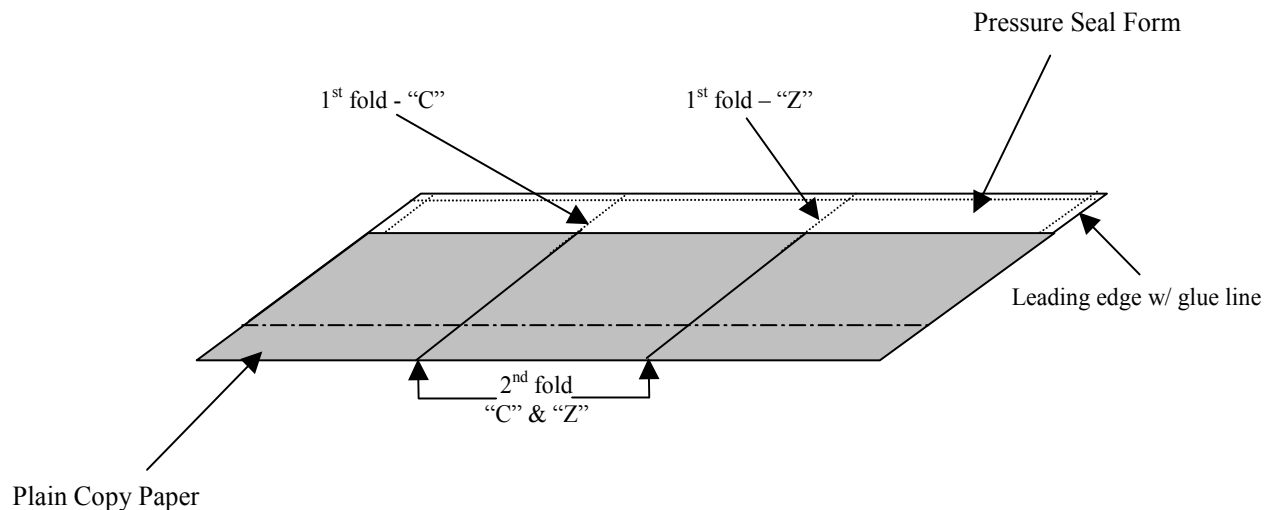

Figure 8

Leading Edge



Make copies of this page on copy paper for fine tuning folds

Instruction For Lining Up Folds

1. Place a stack of these sheets into the feeder and fold one (1) or two (2) sheets.

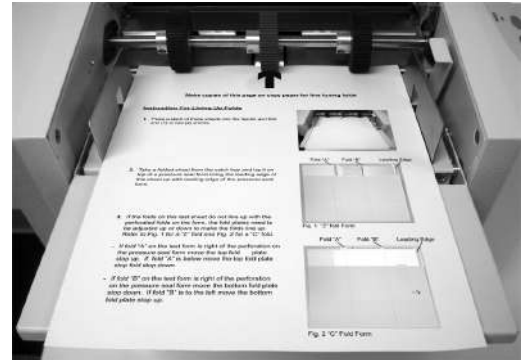

2. Take a folded sheet from the catch tray and lay it on top of a pressure seal form lining the leading edge of this sheet up with leading edge of the pressure seal form.

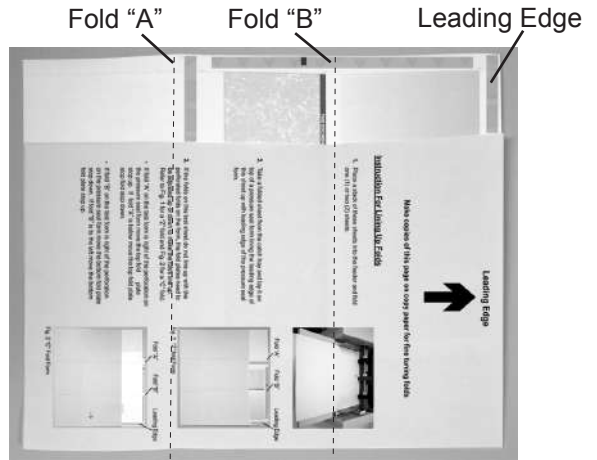

3. If the folds on this test sheet do not line up with the perforated folds on the form, the fold plates need to be adjusted up or down to make the folds line up. Refer to Fig. 1 for a "Z" fold and Fig. 2 for a "C" fold.

- If fold "A" on the test form is right of the perforation on the pressure seal form move the top fold plate stop up. If fold "A" is below move the top fold plate stop fold stop down.
- If fold "B" on the test form is right of the perforation on the pressure seal form move the bottom fold plate stop down. If fold "B" is to the left move the bottom fold plate stop up.

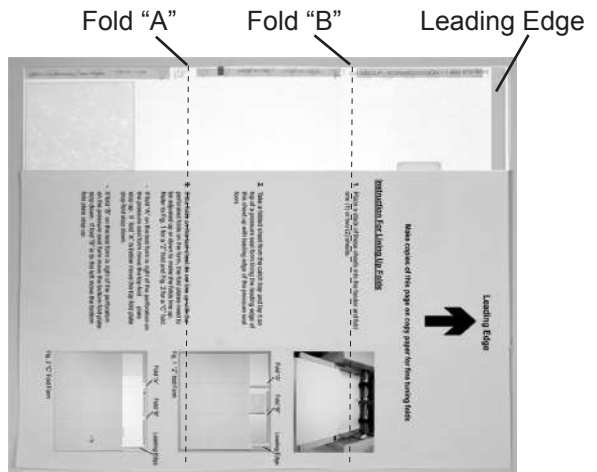
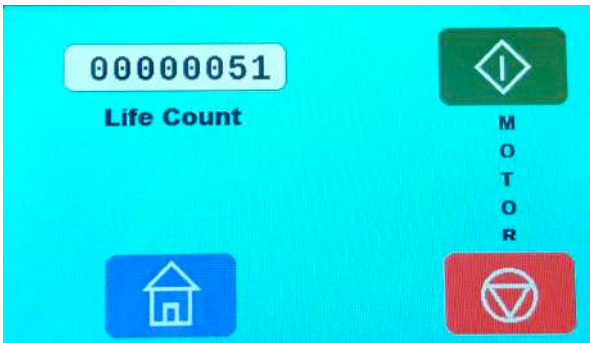
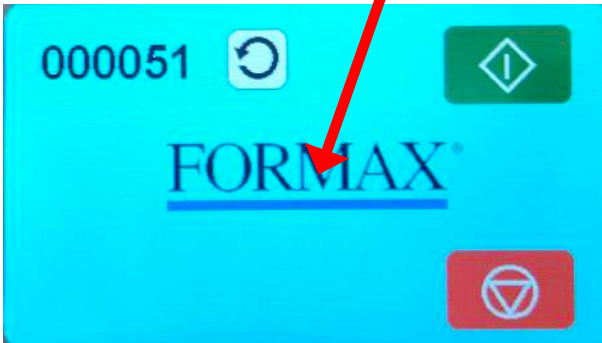

Fig. 2 "C" Fold Form

SERVICE MODE

The service mode can be entered to test the motor operation and view the life count. To enter the service mode press and hold the center of the screen ("M" in FORMAX) for 10 seconds. When in service mode press the green start icon to start the motor and the red stop icon to stop the motor. To exit the service mode press the blue home icon.

Press here



Service mode screen

ADJUSTING THE GATE TIP

To adjust the gate tip, unplug the machine, and then remove bottom fold plate. Turn tee knob (page 15, item #15) counter clockwise until gate singulator pad (page 5) just touches the feed wheel (page 14, item #14) or until the up and down movement of the singulator pad stops. A suggested way of doing this is a push/release/push/release action on the singulator pad while adjusting the t-knob until the up and down movement stops.

ROLLER CLEARANCE:

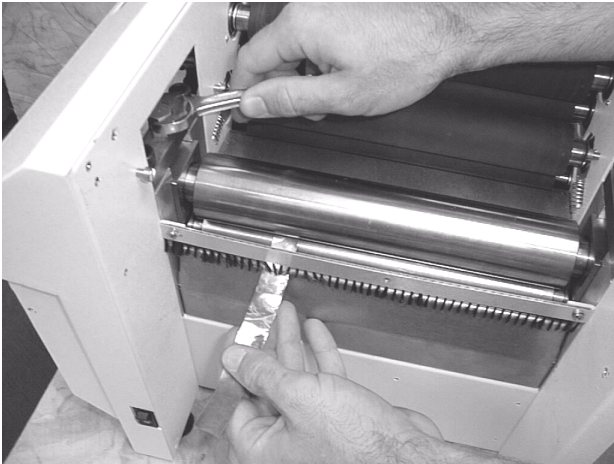

1. Turn power off and unplug the power cord.
2. Loosen locking nuts on the top plates.
3. Insert feeler gauge (0.001") into space between rollers.
4. Turn adjusting bolts while checking clearance with the feeler gauge.
5. Tighten the locking nuts in place after proper clearance has been set.

NOTE: (Double-check spacing with feeler gauge, left to right fine-tuning is required).

TO REPLACE INFEED ROLLERS

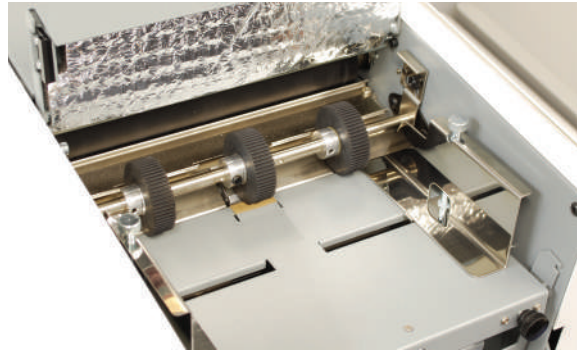
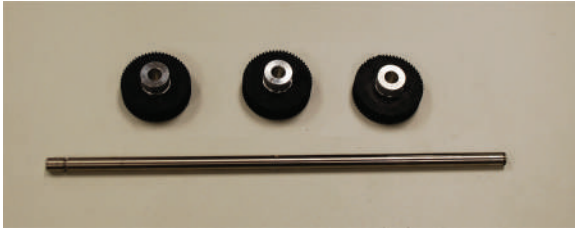

1. Turn power off and unplug the power cord.
2. Open top covers.
3. Loosen thumbscrew inside top cover.
4. Pull up clamp.
5. Remove "E" ring on gear (See Folder Roller page 7).
6. Remove gear and chain (See Folder Roller page 7).
7. Loosen individual rollers (one set screw each).
8. Pull roller bar through each roller in the direction of the removed gear.
9. To reassemble reverse the steps listed above.

TO REPLACE SINGULATOR PAD

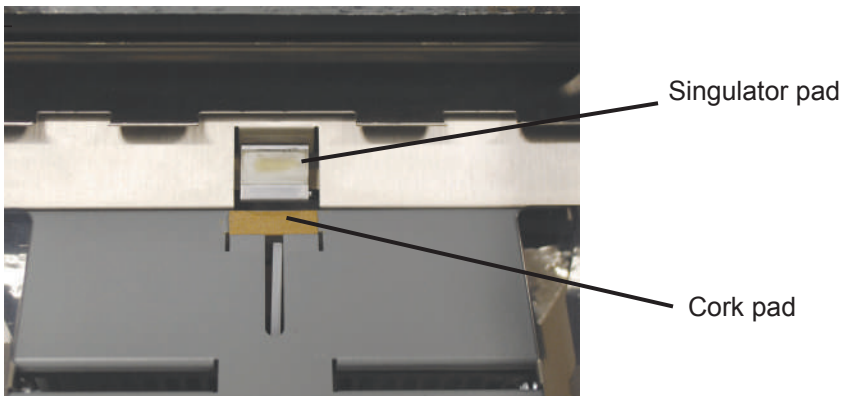

1. Remove in-feed rollers (see in-feed rollers, above).
2. Remove rubber singulator pad, a screwdriver or knife may be need to pry the pad off.
3. Clean singulator mount.
4. Apply super glue to singulator pad and singulator mount.
5. Apply singulator pad to singulator mount, let sit for at least five minutes before reinstalling in-feed rollers.
6. Reinstall in-feed rollers.

TO REPLACE CORK PAD

1. Lower in-feed tray.
2. Remove old cork pad, a screwdriver or knife may be needed to pry the pad off.
3. Clean area of removed pad.
4. Apply super glue to cork pad and in-feed tray.
5. Apply cork pad to in-feed table. Let sit for at least five minutes before operating the machine.

TO REPLACE SEALER ROLLERS

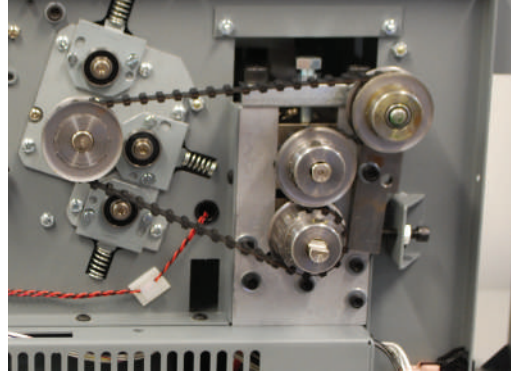

1. Turn power off and unplug power cord.
2. Open covers and remove upper fold plate.
3. Remove belts (see belt replacement, page 7).
4. Remove top plates by unscrewing four screws.
5. Loosen or remove the five lower screws on each side.
6. Remove first roller by lifting up and out of machine.
7. Remove the two springs.
8. To remove second roller tilt stainless steel center away from roller.
9. Then remove second roller the same way as the first roller.
10. To reassemble reverse the steps listed above.
11. Adjust belt tension (see belt replacement page 7).

TO REPLACE FOLDER (RUBBER) ROLLERS

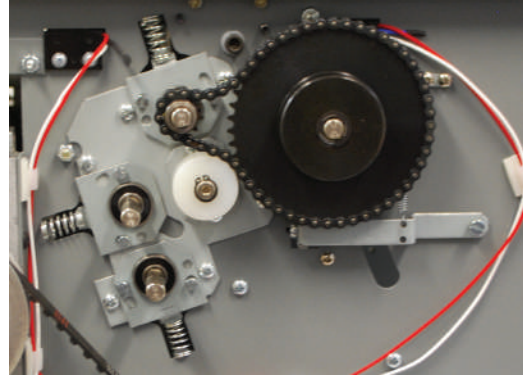
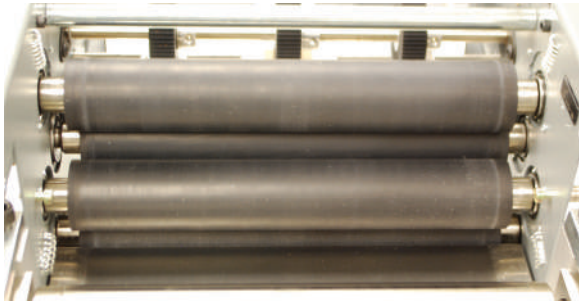

1. Turn power off and unplug power cord.
2. Open covers and remove upper fold plate.
3. Remove control panel.
4. Remove belts (see belt replacement, below).
5. Remove sprocket and chain.
6. Remove idler.
7. Remove bearing by unscrewing the two screws on each bearing assembly (non-operator side).
8. Remove the six screws for the guide panel.
9. Then pull out rollers.
10. To reassemble reverse the steps listed above.

BELT ADJUSTMENT AND REPLACEMENT

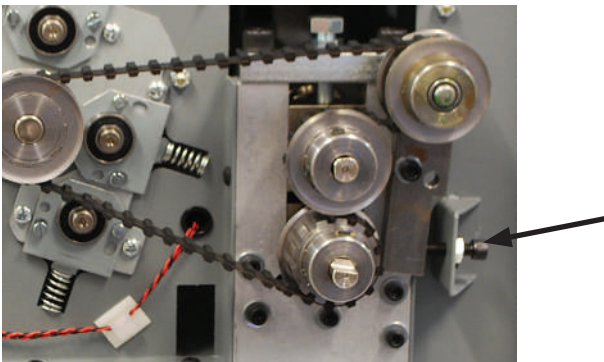

NOTE: Roller clearance must be set before adjusting belt tension.

1. Loosen pivot screw on idler lever turn adjusting screw (see arrow) until belt is loose enough to remove.
2. Install new belt. Turn adjusting screw until belt has 5/16" play, tighten pivot screw.

NOTE: Be sure not to over tighten belt, it will affect roller clearance

PHOTO SENSOR REPLACEMENT:

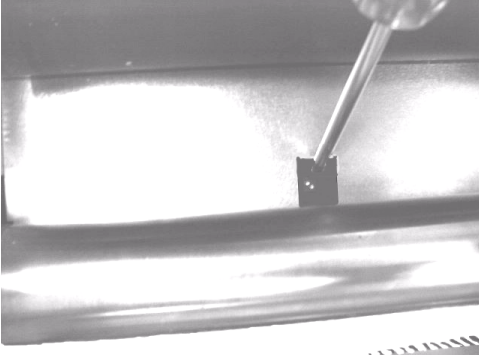

A single photo sensor, just before the pressure rollers, is used for counting and fault detection (i.e. doubles).

1. Loosen the screw on the guide plate.
2. Carefully remove the screw and the photo sensor.
3. Unplug the wires and discard old photo sensor and reinstall the new photo sensor.
4. Reverse the previous step to reinstall the new photo sensor.
5. Adjust the photo sensor to 1/8" below the guide plate.
6. Then tighten the screw to ensure the photo sensor does not move.

FD 2006/2036 120V ELECTRICAL SCHEMATIC

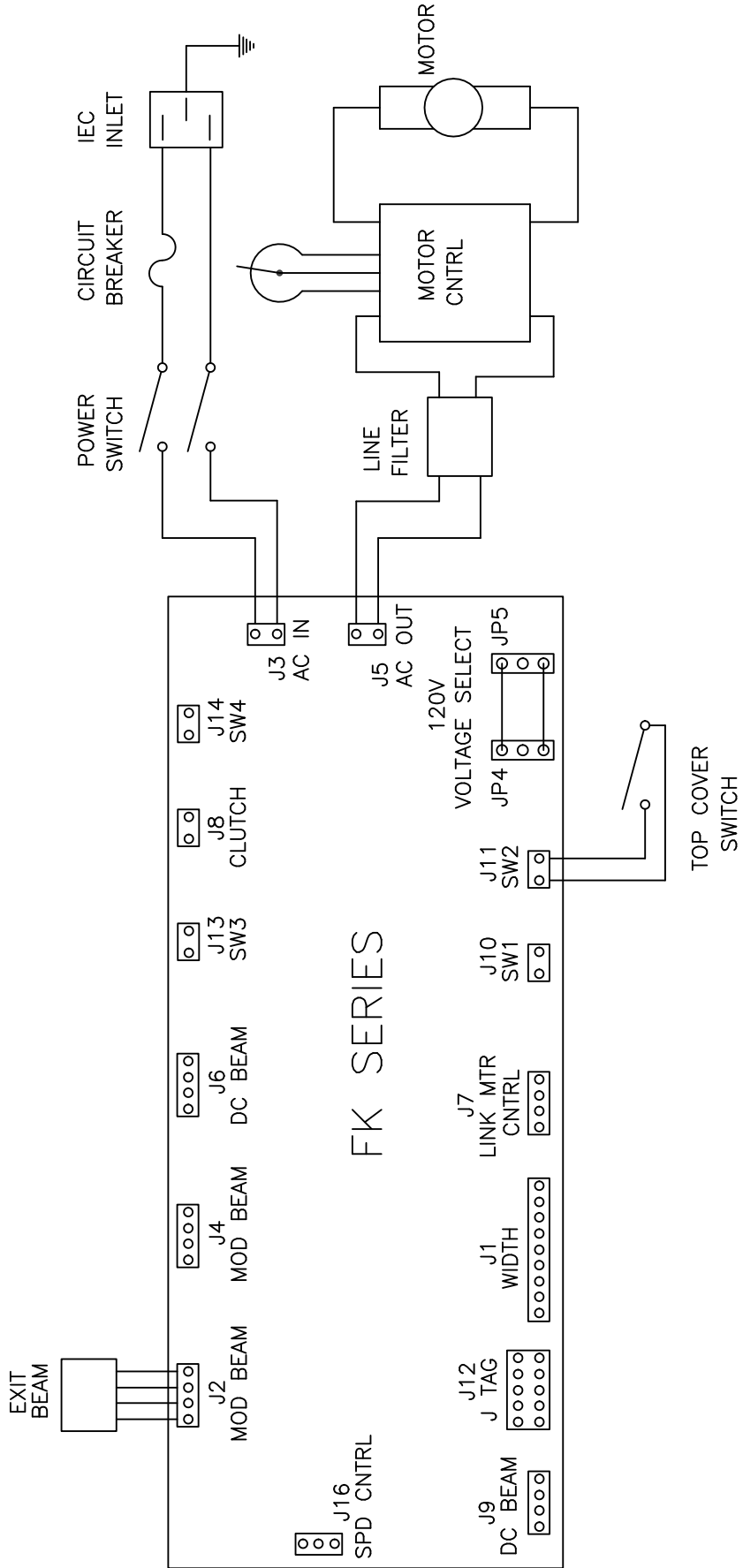

FE 2006/2036 220V ELECTRICAL SCHEMATIC

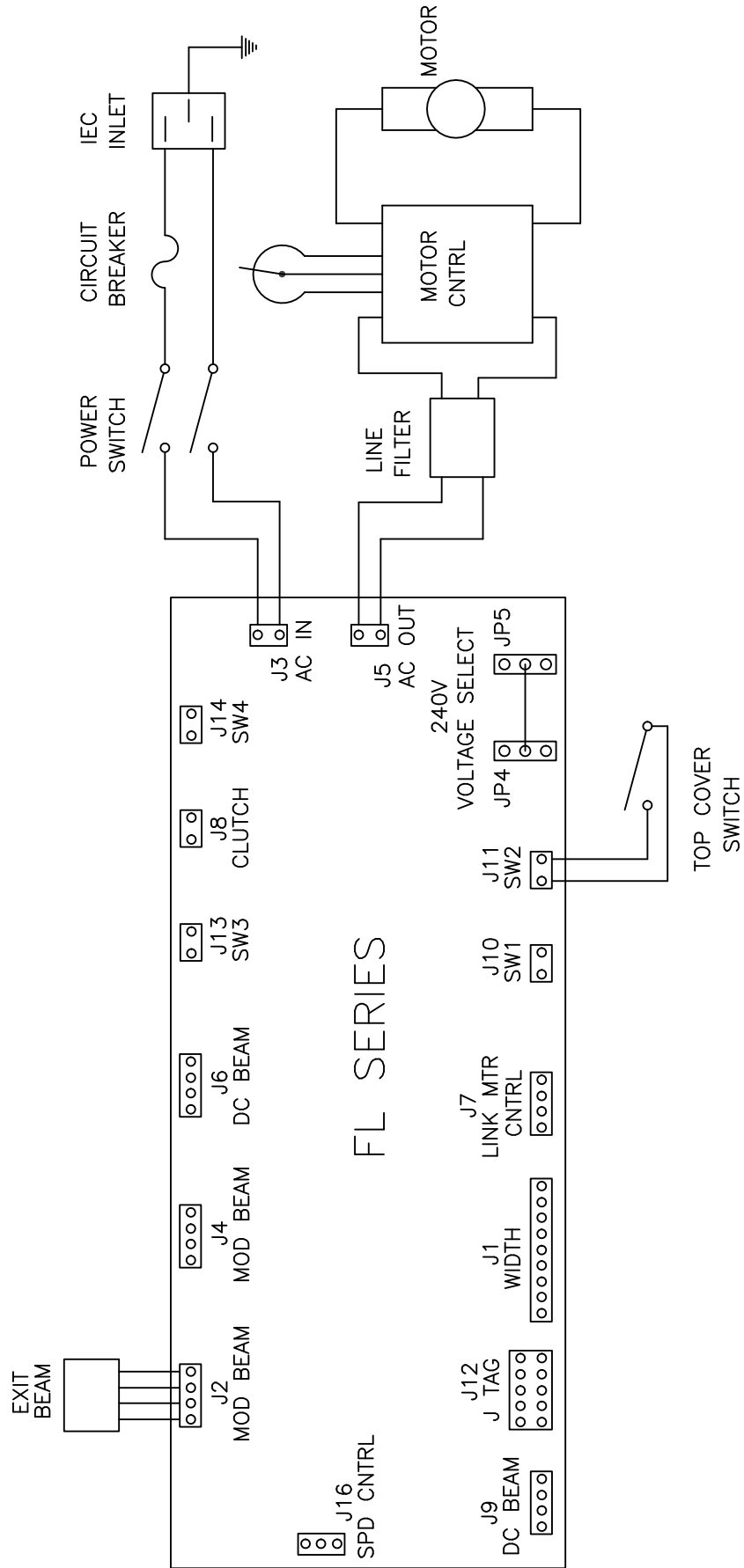

PARTS LIST

EXTERIOR

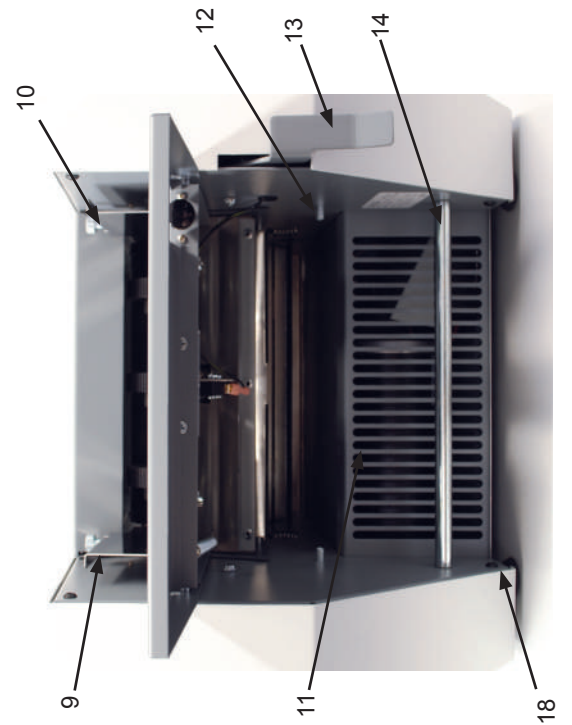
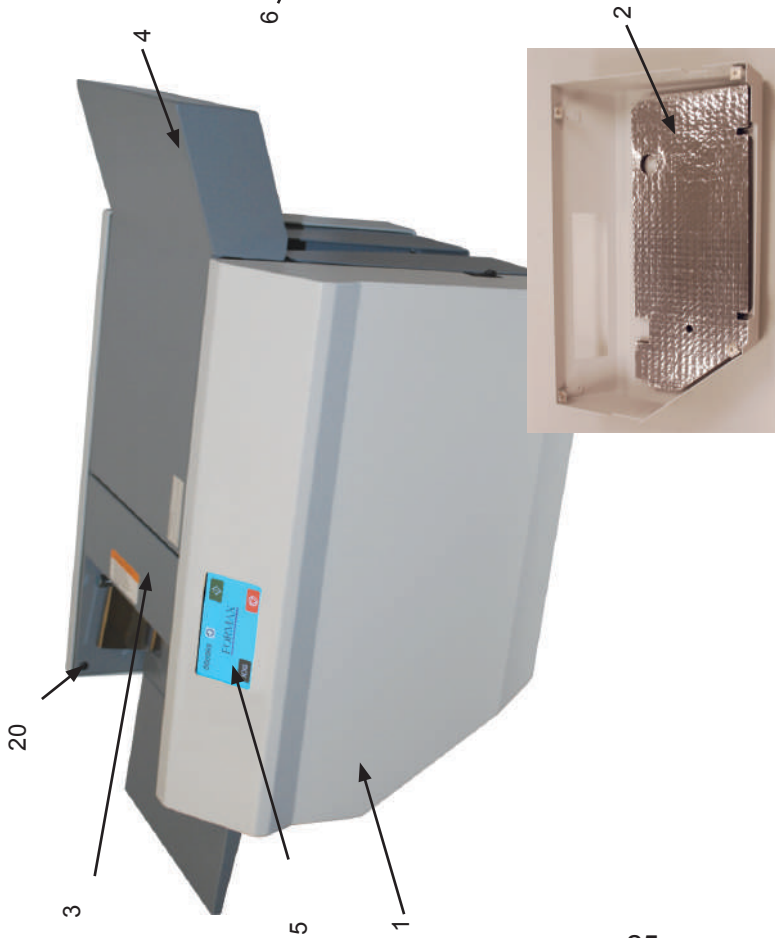
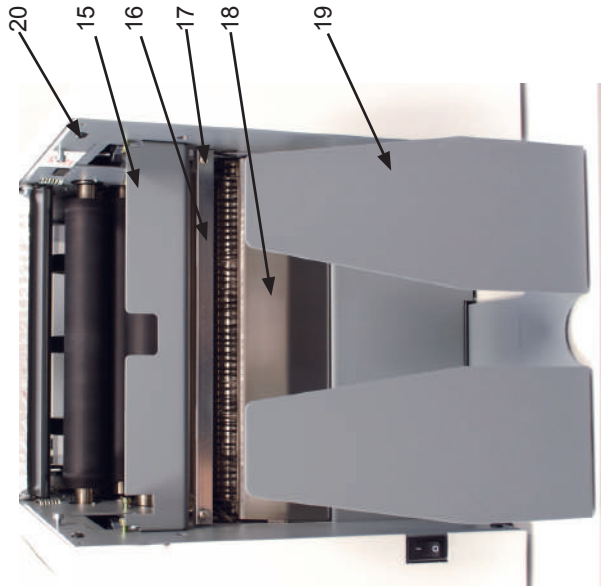
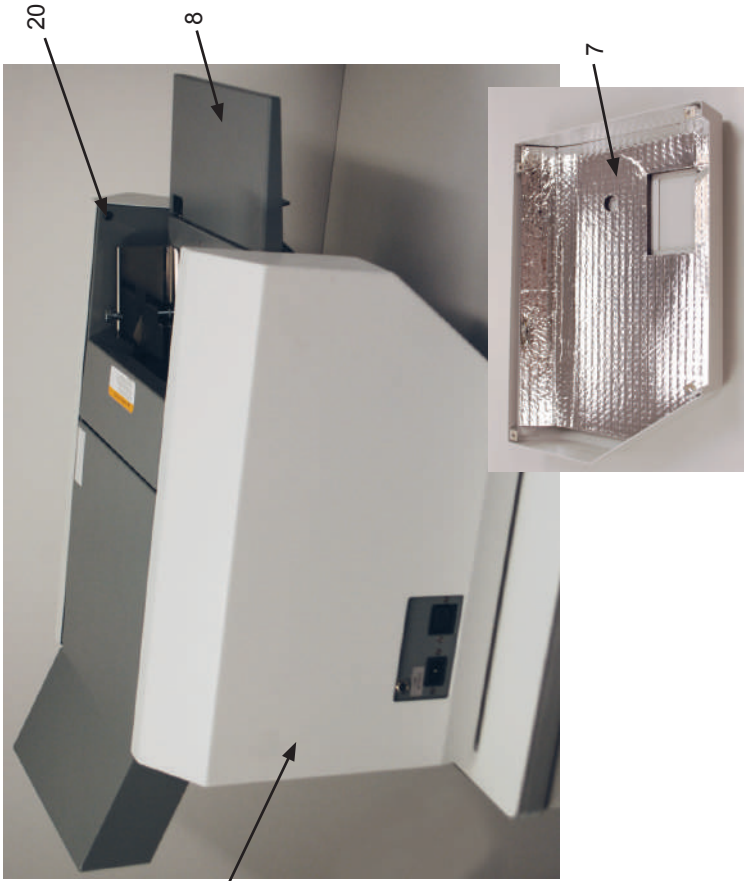

EXTERIOR

ITEM	PART	DESCRIPTION	QTY.
1	395-1379	OPERATOR COVER ASSY.	1
	360-3086	OPERATOR COVER	1
2	305-0043	ACOUSTIC FOAM OP COVER	1
3	395-1279	IN FEED COVER ASSY.	1
-	360-2796	IN FEED COVER	1
-	305-0040	ACOUST. FOAM IN FEED COVER	1
4	395-1280	TOP COVER ASSY.	1
-	305-0041	ACOUST. FOAM 11" TOP COV.	1
-	360-2800	TOP COVER 2006/2036	1
5	395-1371	TOUCHSCREEN ASSY (120V)	1
	395-1372	TOUCHSCREEN ASSY (220V)	1
6	395-1277	NON-OPER. COVER ASSY.	1
	360-2790	NON-OPER. COVER	1
7	305-0039	ACOUSTIC FOAM NON-OP COVER	1
8	360-2793	PAPER TRAY EXTENSION	1
9	360-2289	NON-OP SIDE GUIDE	1
10	360-2290	OP SIDE GUIDE	1
11	360-3088	BASE	1
12	332-0132	SUPPORT PIN	4
13	360-3107	PAPER LOAD HANDLE	1
14	332-0121	BRACE SHAFT	1
15	360-2801	ROLLER GUARD	1
16	316-0011	STATIC BRUSH	1
17	373-5869	STATIC BRUSH MOUNT.SCREWS	2
18	360-1686	CROSS MEMBER REAR	1
19	360-2802	CATCH TRAY ASSY	1
-	325-0413	CATCH TRAY DECAL	1
20	375-5983	#10-32 x 1.00, SOCKET HEAD SCREW	8

INFEED

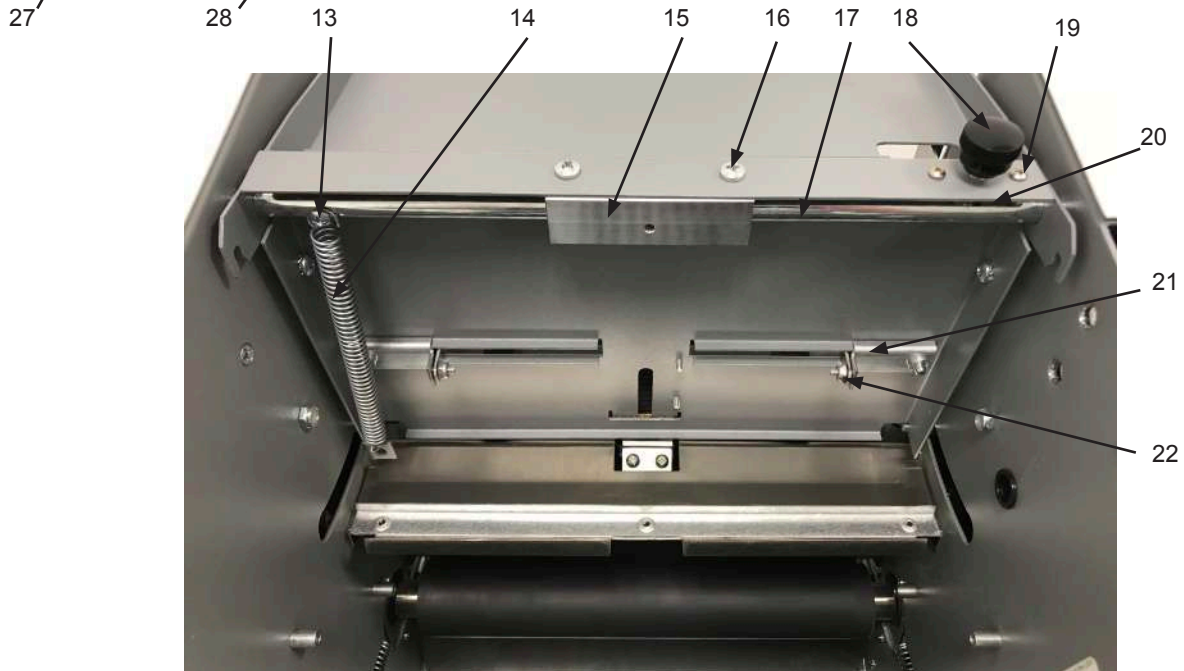
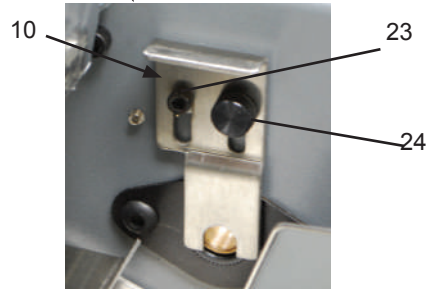
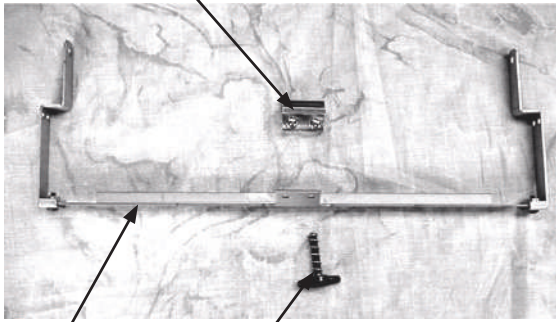
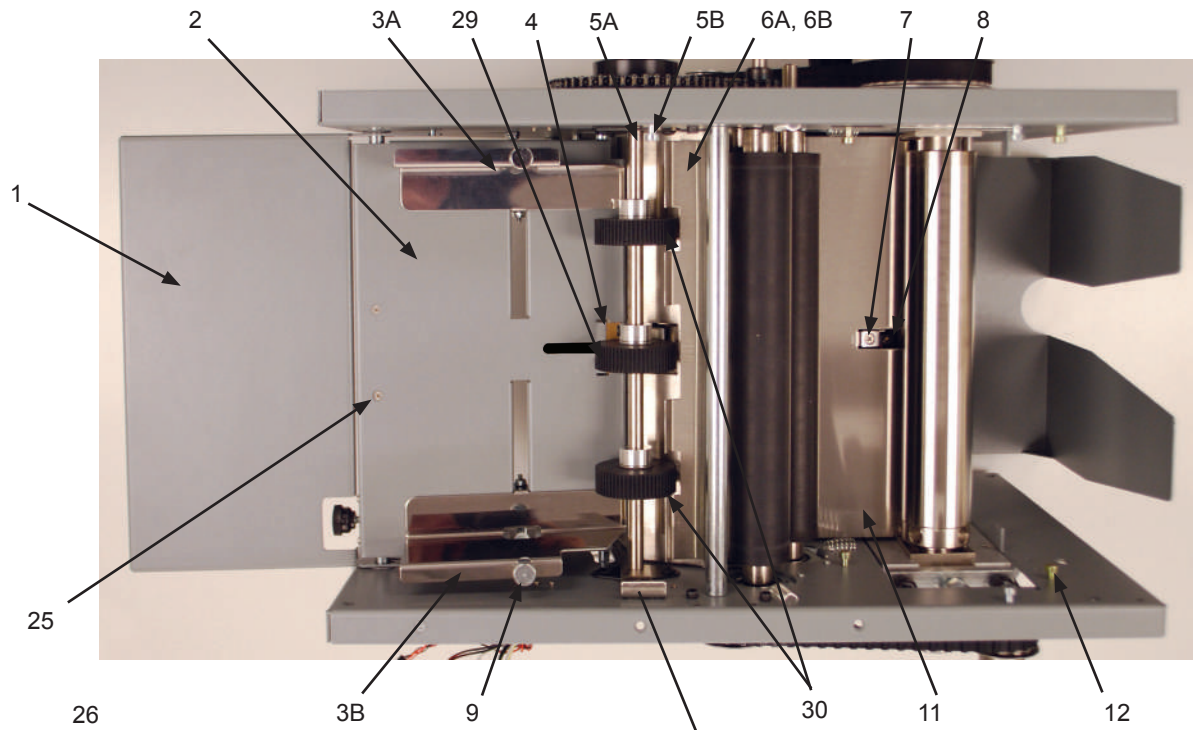

INFEED

ITEM	PART #	DESCRIPTION	QTY
1	360-2793	PAPER TRAY EXTENSION	1
2	360-3117	PAPER, TRAY	1
3A	360-2289	NON-OP SIDE GUIDE	1
3B	360-2290	OP SIDE GUIDE	1
4	352-0009	CORK PAD WITH GLUE	1
5A	331-0145	ROLLER ROD, FEED	1
5B	375-0116	SHOULDER SCREW #8-32	3
6A	360-1685	PAPER RAMP GUIDE	1
6B	373-5893	RAMP GUIDE SCREW	4
7	360-1700	BRACKET SENSOR	1
8	310-0134	PHOTO SENSOR HARNESS	1
9	375-0123	SIDE GUIDE, ADJ. SCREW	2
10	360-1643	RETAINER BRACKET	1
11	360-1687	CROSS MEMBER FRONT	1
12	375-0144	YELLOW ZINC SHOULDER SCREW	4
13	373-5482	SCREW PPH 6-32 x 1/2 LG. NI	1
14	342-0096	SPRING EXTENSION	1
15	334-0373	PIVOT BLOCK	1
16	373-0129	PHIL DRIVE SCREW	1
17	331-0225	SHAFT, PAPER TRAY	1
18	372-0098	PLASTIC THUMB SCREW, KNURLED	1
19	373-0131	PHILLIPS, SCREWS, CHROME	2
20	360-1936	NUT RETAINER	1
21	360-3141	SIDE GUIDE BRACKET MOUNT	2
22	378-0123	6-32 LOCKNUT (NYLON)	4
23	375-0004	SOC. HD. CAP SCREW	1
24	395-0889	THUMB SCREW ASSY	1
25	373-0119	#4-40 X 3/16", FLT HD UNDERCUT	2
26	395-0789	SINGULATOR ASSY.	1
-	352-0008	SINGULATOR PAD	1
-	334-0358	SINGULATOR MOUNT	1
-	373-5893	SCREW 6-32 x 3/8 PPH	2
27	360-1648	SINGULATOR BRACKET	1
28	395-0892	T KNOB ASSY.	1
29	350-0081	GREY CENTER HARD-COMPOUND FEED TIRE	1
30	350-0099	BLACK SOFT-COMPOUND FEED TIRES	2

OPERATOR SIDE

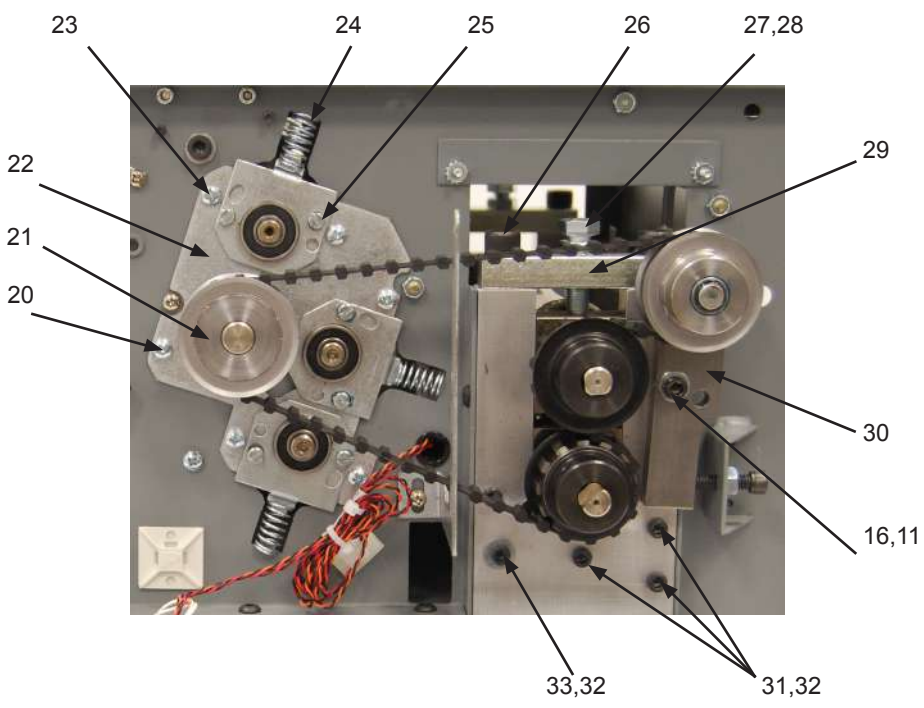
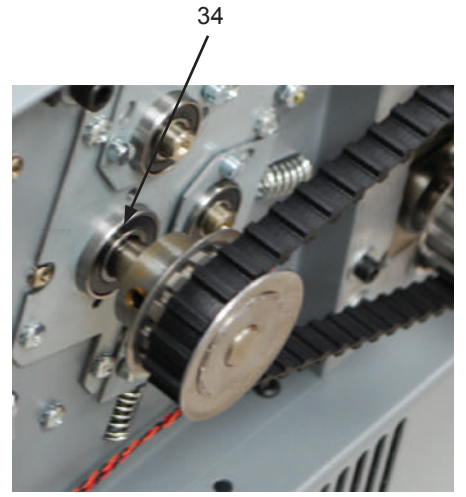
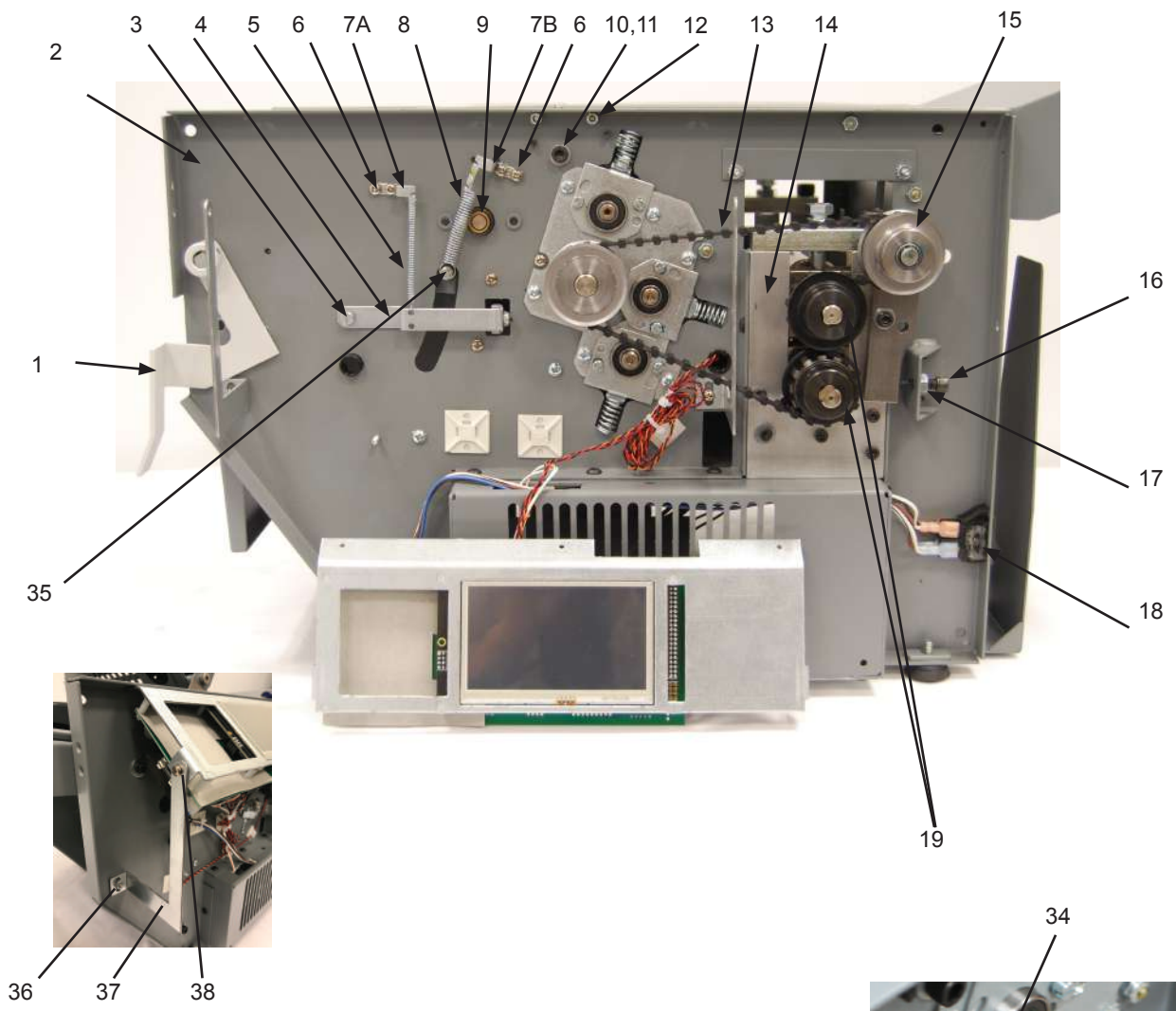

OPERATOR SIDE

ITEM	PART #	DESCRIPTION	QTY
1	360-3107	PAPER LOAD HANDLE	1
2	360-2789	FRAME OPERATOR	1
3	375-0116	SHOULDER SCREW #8-32	1
4	360-1649	SINGULATOR BRACKET ARM	2
5	342-0077	EXTENSION SPRING .188 O. D.	2
6	375-5699	SCREW 10-32 X 1/4 BUTTON HD CA	4
7A	360-1645	SPRING BRACKET RT	1
7B	360-1659	SPRING BRACKET LT	
8	342-0078	EXTENSION SPRING. 375 O. D	2
9	371-0076	BUSHING SELF ALIGN	2
10	374-0040	SOC. HD. CAP SCREW	2
11	377-2611	¼ LOCK WASHER	2
12	378-0130	8-32 NUT/FOR SHOULDER SCREW	4
13	365-0179	TIMING BELT DOUBLE SIDED	1
14	334-0356	SIDE PLATE	2
15	395-0764	PULLEY, 13T.38 PITCH ASSY.	1
16	374-5832	¼-20 SOC. HD. CAP SCREW	2
17	378-6549	¼-20 KEP NUT	1
18	311-0087	ROCKER SWITCH	1
19	365-0145	PULLEY, 13T .38 PITCH	2
20	373-0018	SHOULDER SCREW #8-32	12
21	365-0177	PULLEY, 13T .38 PITCH, MOD.	1
22	360-1638	ROLLER SIDE BRACKET	2
23	360-1660	ROLLER SPRING BRACKET	6
24	342-0076	COMPRESSION SPRING	6
25	375-0116	SHOULDER SCREW	12
26	375-0102	3/8X1 1/4" SOC. HD. SC.	4
27	375-0152	3/8" X 1 1/4" HEX HD.	2
28	375-0141	3/8"-40 HEX JAM NUT	2
29	334-0430	BRACKET SIDE, FRAME CAP	2
30	334-0371	BRACKET ADJ IDLER	1
31	374-0096	#10-32 X 1.00, SOC HD CAP	8
32	377-5298	FLAT WASHER	10
33	375-0106	10-32X 3/4 SOC HD CAP	2
34	370-0026	BEARING ROLLER DOUBLE SEAL	1
35	330-0084	SHOULDER SCREW	-
36	378-9500	6-32 NUT W/STAR WASHER	1
37	360-3091	PCB BRACKET BRACE	2
38	330-0084	6-32X1/4" PPH SCREW W/ INT STAR	2

NON-OPERATOR SIDE

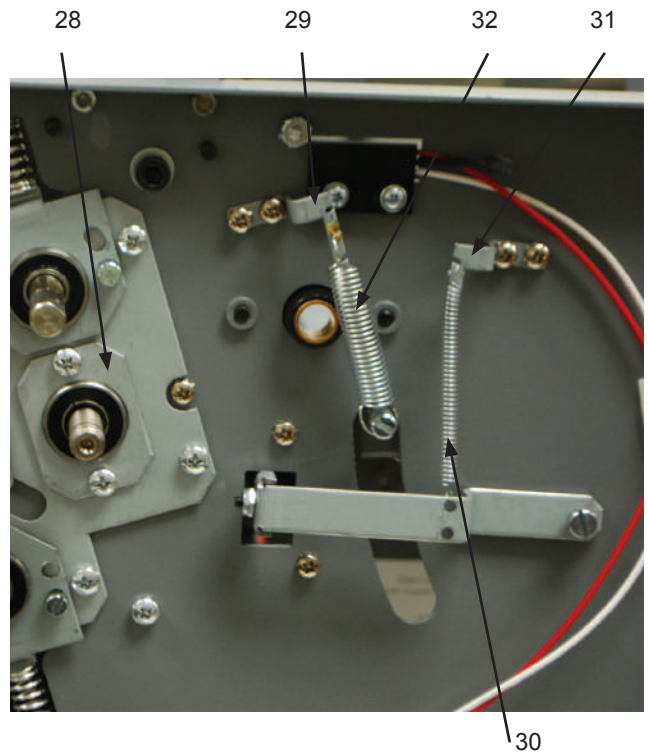
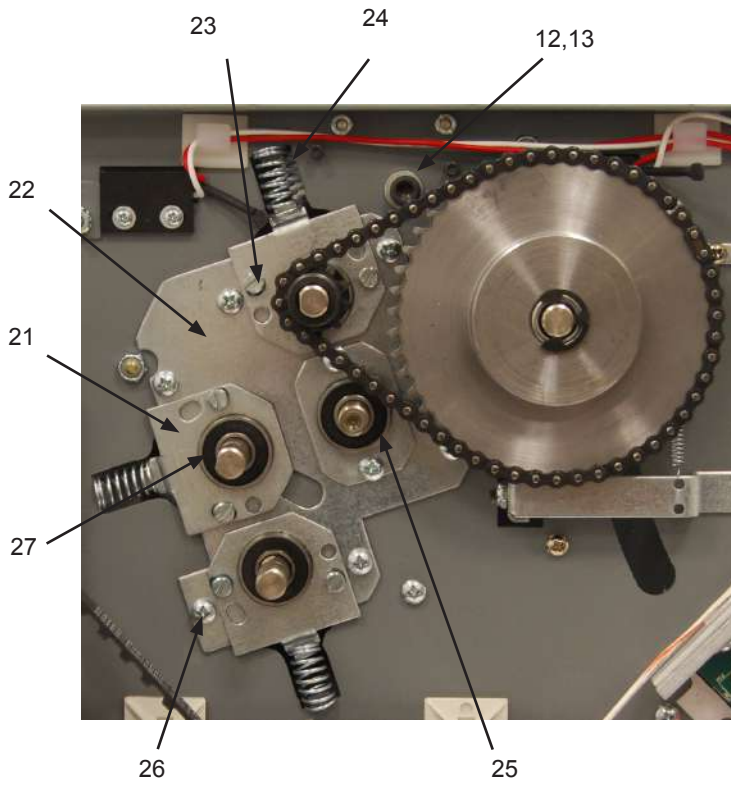
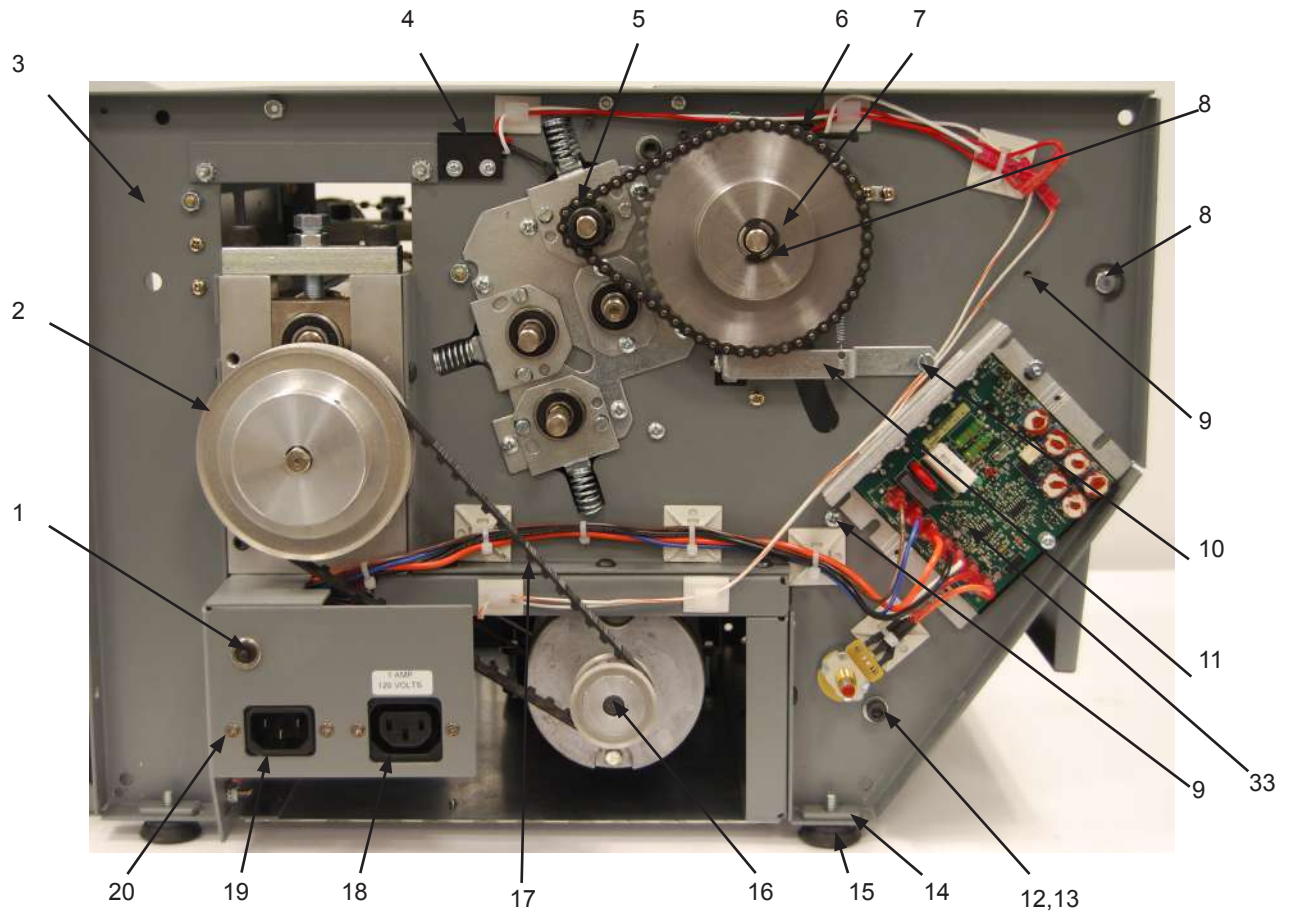

NON-OPERATOR SIDE

ITEM	PART #	DESCRIPTION	QTY
1	317-0029	CIRCUIT BREAKER 2.5 AMP 120V & 240V	1
2	365-0178	PULLEY, 3/8 PITCH, 28 L050	1
3	360-2788	FRAME NON-OPERATOR	1
4	319-0213	PROXIMITY SENSOR	2
-	319-0159	MAGNET, ACTUATOR	2
5	367-4073	10 TOOTH SPROCKET	1
6	367-0033	CHAIN	1
-	367-1092	MASTER LINK	1
7	395-1074	48 TOOTH SPROCKET ASSY.	1
8	379-0014	3/8 E TYPE RETAINING RING	1
9	375-0044	SCREWS FOR SUPPORT PINS	4
10	375-0116	SHOULDER SCREW #8-32	1
11	360-1649	SINGULATOR BRACKET	2
12	374-0040	SOC. HD. CAP SCREW	2
13	377-2611	¼ LOCK WASHER	2
14	378-6549	¼-20 KEP NUT	4
15	372-6544	NON-SWIVEL ADJ. GLIDE	4
16	365-0163	DRIVE PULLEY 9T. (9L050) (FD 2006)	1
-	365-0233	DRIVE PULLEY, 11T L 3/8 BORE (FD 2036)	1
17	365-0180	GEAR BELT, 210L050	1
18	319-0109	IEC-320 POWER OUTLET	1
19	319-0096	RECESSED POWER RECEPTACLE	1
20	375-6625	6-32X3/8" PHIL DRIVE FLAT HD	4
21	360-1660	ROLLER SPRING BRACKET	3
22	360-1638	ROLLER SIDE BRACKET	2
23	375-0116	SHOULDER SCREW #8-32	12
24	342-0076	COMPRESSION SPRING	6
25	320-0087	IDLER, .377 ID X 1.25 OD X .635 NYLON	1
26	375-0116	SHOULDER SCREW #8-32	14
27	370-0025	ROLLER BEARING	7
28	360-1661	BEARING BRACKET	1
29	360-1645	SPRING BRACKET RT	1
30	342-0077	EXTENSION SPRING .188 O. D.	2
31	360-1659	SPRING BRACKET LT	1
32	342-0078	EXTENSION SPRING. 375 O. D	2
33	395-1377	DC MOTOR CONTROL ASSY (120V)	1
-	395-1378	DC MOTOR CONTROL ASSY (220V)	1

UNDERSIDE

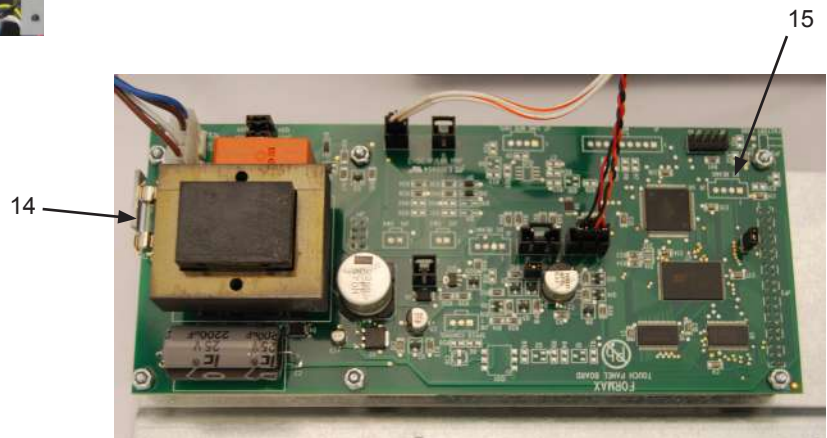
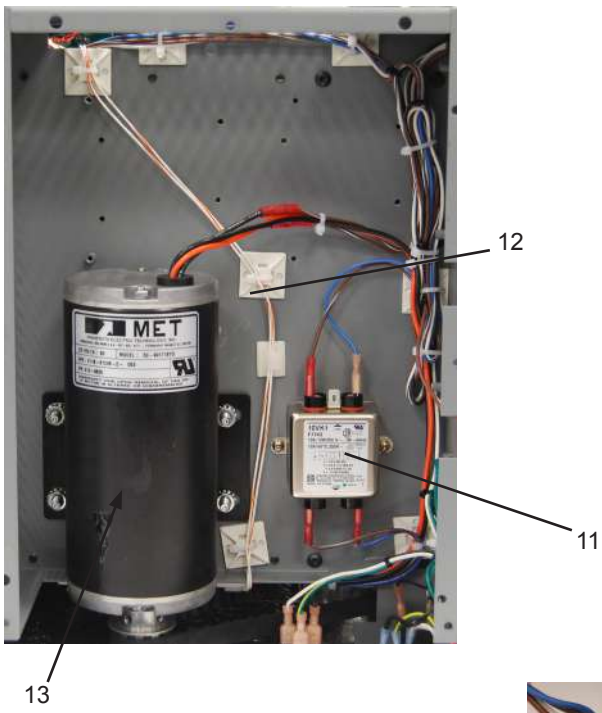
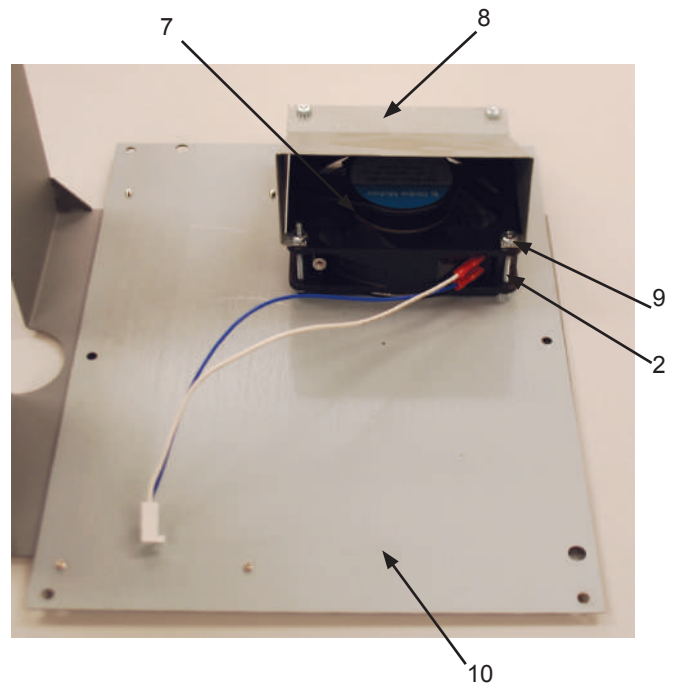
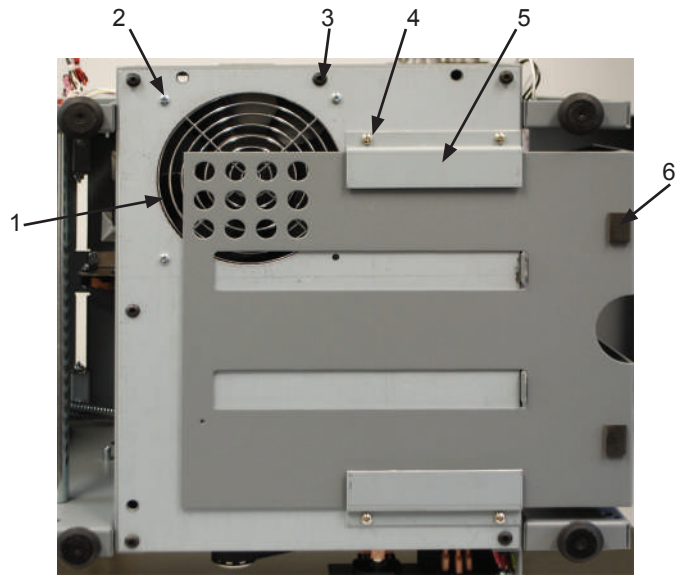

UNDERSIDE

ITEM	PART	DESCRIPTION	QTY.
1	341-0006	FAN GUARD	1
2	375-0098	6-32 X 1 1/2" PPH SCREW	4
3	375-5699	#10-32 x 1.00, SOCKET HEAD SCREW	6
4	373-5869	SCREW 10-32 X 1/4 BUTTON HD CA	4
5	360-1656	RAIL, CATCH TRAY	2
6	351-0013	SUPPORT PAD	3
7	313-0004	COOLING FAN 110V	1
-	313-0014	COOLING FAN 240V	1
8	360-1490	FAN DUCT 209010	1
9	378-9500	6-32 NUT WITH STAR WASHER	4
10	360-1674	BOTTOM PAN	1
11	319-0078	LINE FILTER	1
12	315-5800	CABLE TIE MOUNT	5
13	313-8835	1/6 HP MOTOR 120V & 240V	1
14	317-0040	FUSE 250AMP 5X20 FAST ACTING	
15	395-1371	TOUCHSCREEN ASSY (120V)	1
	395-1372	TOUCHSCREEN ASSY (220V)	1

LOWER FOLD PLATE 395-1282

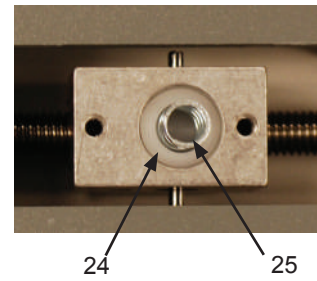
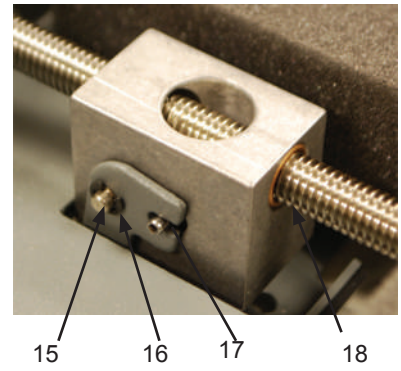
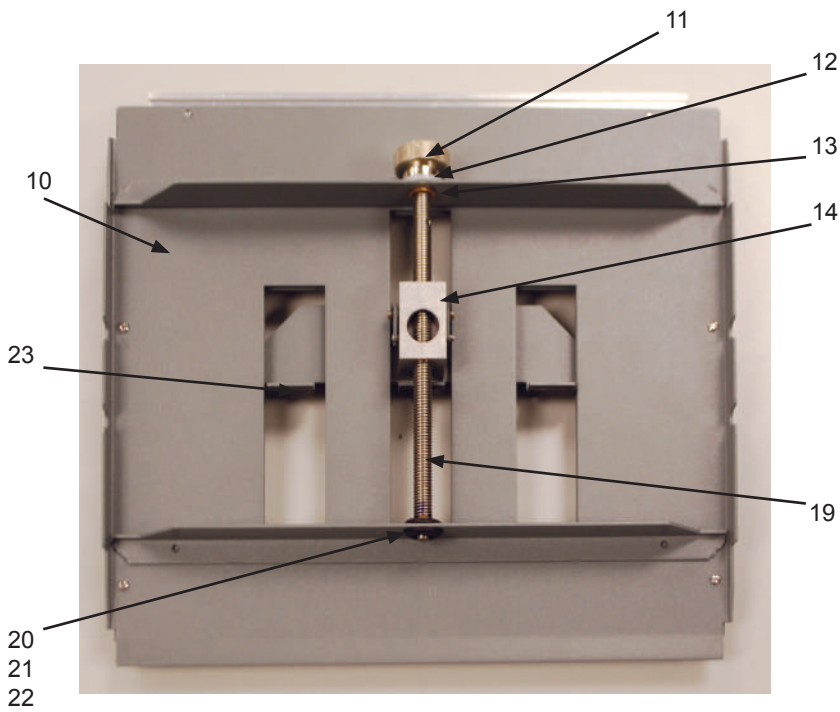
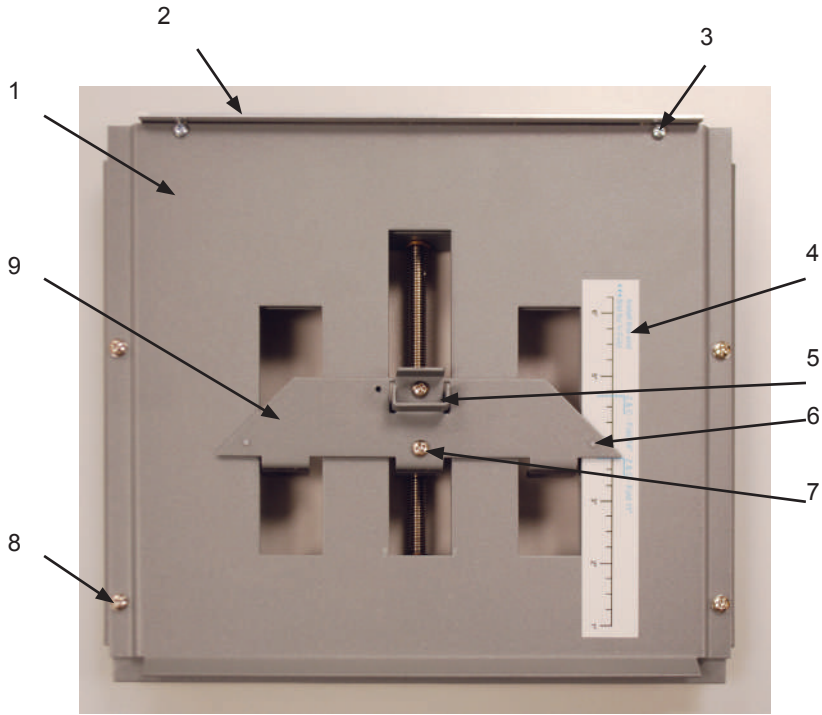

LOWER FOLD PLATE 395-1282

ITEM	PART	DESCRIPTION	QTY.
*	395-1282	LOWER FOLD PLATE ASSY.	1
1	360-2784	UPPER HALF, LOWER FOLD PLATE	1
2	360-1641	FOLD DIVERTER	1
3	373-0014	SCREW PPH 4-40 x 1/4 LG.	2
-	377-0084	WASHER, #4 FLAT MACHINE SCREW	2
4	325-0400	LOWER FOLD PLATE DECAL	
-	325-0549	LOWER FOLD PLATE DECAL (FE models only)	1
5	360-2663	RELEASE LEVER, FOLLOWER	1
6	381-0114	NYLON RIVET	2
7	373-0132	#6-32X1/4 PPH SCREW CHROME	2
8	373-5869	SCREW PPH 6-32x1/4	4
9	360-2664	PAPER STOP	2
10	360-2785	LOWER HALF, LOWER FOLD PLATE	1
11	334-0378	KNOB, FOLD PLATE ADJUSTMENT	1
12	377-0072	3/8 NYLON WASHER	1
13	371-0092	3/16X5/16X3/16 FLANGED BUSHING	1
14	334-0374	CAR	1
15	332-0148	RELEASE PIN, FOLD PLATE	1
16	379-0020	1/8" E TYPE RETAINING RING	2
17	381-0121	3/32 X 1 ROLL PIN	1
18	371-0096	.296 X 3/8 X 1/4 SLEEVE BUSHING	2
19	331-0224	LOWER LEAD SCREW	1
20	352-0014	GROMMET FLANGED RUBBER	1
21	371-0093	3/16 X 5/16 X 1/4 SLEEVE BUSHING	1
22	379-0009	RETAINING RING, 3/16 I.D.	1
23	352-0016	PAD, PAPER STOP	3
24	395-1384	NUT, RELEASE, FOLD PLATE	1
25	342-0091	COMPRESSION SPRING, FOLD PLATE	1

UPPER FOLD PLATE 395-1283

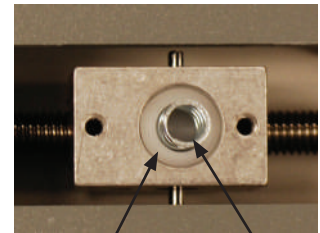
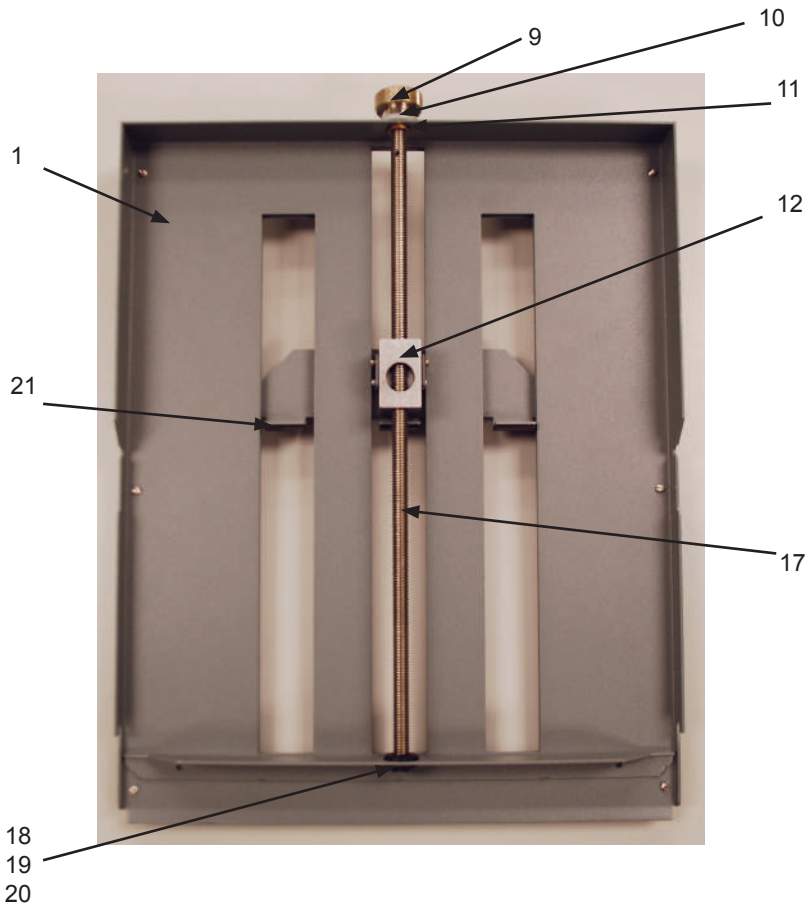
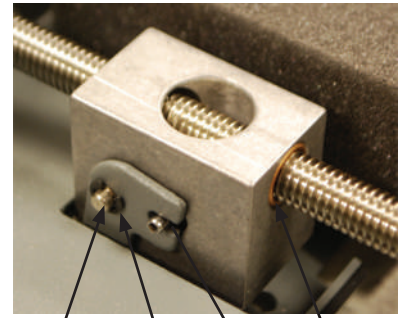
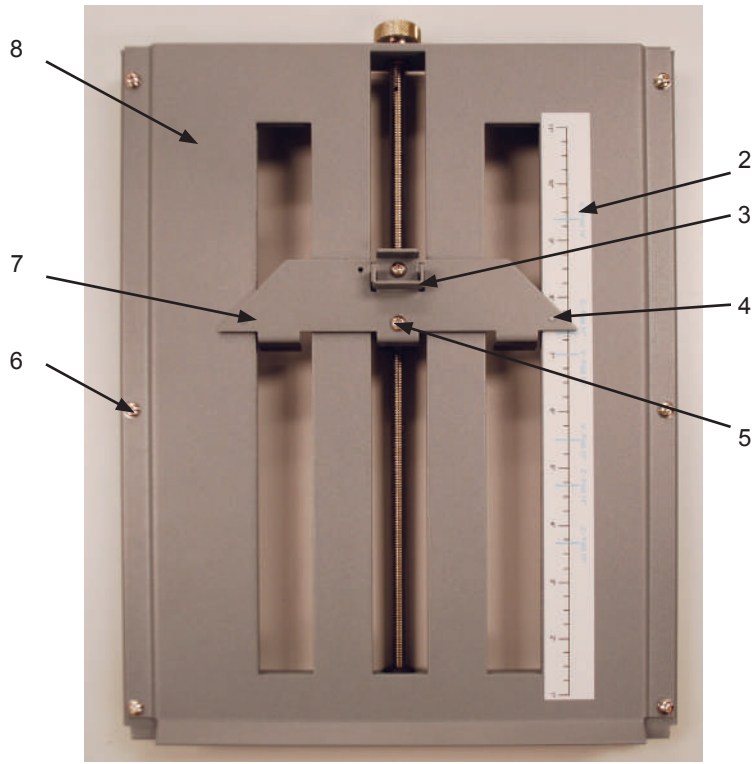

UPPER FOLD PLATE 395-1283

ITEM	PART	DESCRIPTION	QTY.
*	395-1283	UPPER FOLD PLATE ASSY 2002 & 2032	1
1	360-2787	LOWER HALF, UPPER FOLD PLATE	1
2	325-0459	FOLD PLATE DECAL UPPER FOLD PLATE 14"	1
-	325-0549	UPPER FOLD PLATE DECAL (FE models only)	1
3	360-2663	RELEASE LEVER, FOLLOWER	1
4	381-0114	NYLON RIVET	2
5	373-0132	#6-32X1/4 PPH SCREW CHROME	2
6	373-5869	SCREW PPH 6-32x1/4	4
7	360-2664	PAPER STOP	2
8	360-2786	UPPER HALF, UPPER FOLD PLATE	1
9	334-0378	KNOB, FOLD PLATE ADJUSTMENT	1
10	377-0072	3/8 NYLON WASHER	1
11	371-0092	3/16X5/16X3/16 FLANGED BUSHING	1
12	334-0374	CAR	1
13	332-0148	RELEASE PIN, FOLD PLATE	1
14	379-0020	1/8" E TYPE RETAINING RING	2
15	381-0121	3/32 X 1 ROLL PIN <	1
16	371-0096	.296 X 3/8 X 1/4 SLEEVE BUSHING	2
17	331-0223	UPPER LEAD SCREW	1
18	352-0014	GROMMET FLANGED RUBBER	1
19	371-0093	3/16 X 5/16 X 1/4 SLEEVE BUSHING	1
20	379-0009	RETAINING RING, 3/16 I.D. >	1
21	352-0016	PAD, PAPER STOP	3
22	395-1384	NUT, RELEASE, FOLD PLATE	1
23	342-0091	COMPRESSION SPRING, FOLD PLATE	1

FOLD & SEAL ROLLERS

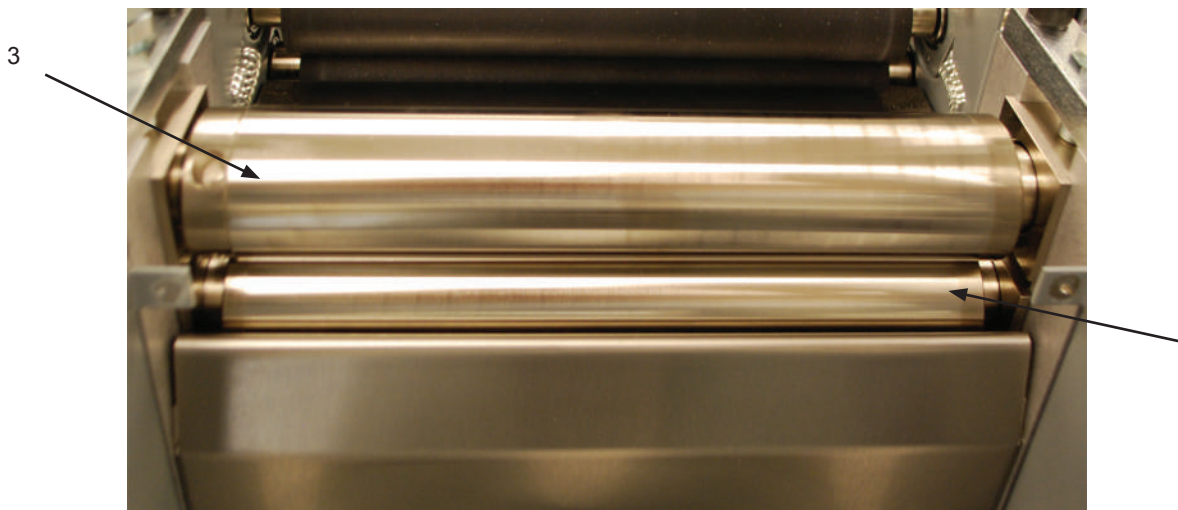
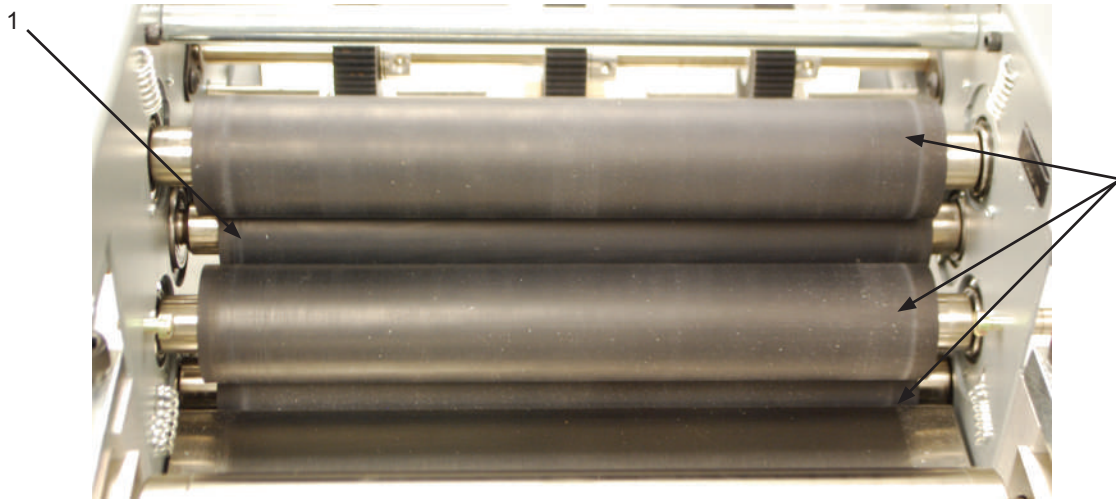

ITEM	PART	DESCRIPTION	QTY.
1	350-0075	DRIVE FOLD ROLLER	1
2	350-0077	FOLD ROLLER	3
3	395-0760	UPPER SEAL ROLLER ASSY	1
4	395-0761	DRIVE SEAL ROLLER ASSY	1
NS	342-0063	SPRING SEAL ROLLER BEARING BLOCK	2